

Visual Measuring- & Testing Instruments

Collimators, Testing Telescopes, Autocollimators and Alignment Systems

INNOVATION AND QUALITY

This catalogue has been developed to offer solutions for common measuring tasks and gives an overview of visual autocollimators, collimators, testing telescopes, alignment systems, diopter telescopes, dynameters, modules and accessories.

The following table helps you to select the correct instrument group for specific measurement tasks.

Typical measurement tasks		Collimators	Testing Telescopes	Autocollimators	Diopter Telescopes	Dynameters	Alignment Systems
Optics	Measurement of						
	Angles	▣	▣	▣			
	Back Focal Length	▣	▣	▣			
	Focal Length	▣	▣				
	Optical Power	▣	▣				
	Parallelism of windows/flats	▣	▣	▣			
	Pyramidal error			▣			
	Radius of Curvature			▣			
	Sphericity (qualitative)			▣			
	Flatness of windows (qualitative)	▣	▣	▣			
	Measurement of						
	Optical Power				▣		
	Diopter Graduation				▣		
	Testing of Telescopes						
	Distance Setting	▣					
	Exit pupil					▣	
	Field of View	▣					
Graduation of Reticle	▣						
Magnification					▣		
Resolution	▣						
Machine Tool Industry	Measurement of						
	Index Tables			▣			
	Flatness of Surface Plates			▣			
	Straightness of guideways			▣			
	Parallelism of guideways			▣			
	Squareness of guideways			▣			
	Alignment of						
Guideways and Tables						▣	
Bore Holes and Bearings						▣	



INTRODUCTION04

COLLIMATORS06 Focus set to infinity8
Focus adjustable14

TESTING TELESCOPES .20 Focus set to infinity22
Focus adjustable34

AUTOCOLLIMATORS . . .42 Focus set to infinity44
Focus adjustable60

MODULES72 Objective tubes (infinity)74
Objective tubes with tube extension75
Reticle sleeves with illumination76
Reticle sleeves with eyepiece77
Autocollimation eyepieces78
Eyepieces80
Illuminations81

RETICLES82 Crosshairs83 Scales86
Double crosshairs . . .83 Resolution tests87
Tolerance reticles . . .83 Foucault-Tests87
Angle graduated84 Siemens stars87
Line graduated85
Diaphragms85
Concentric circles . . .86

Temporarily not available!

ALIGNMENT SYSTEMS .88 Alignment collimators88
Alignment telescopes90
Alignment autocollimators91

OTHER INSTRUMENTS .92 Diopter telescopes92
Dynameter92
Reading telescopes93
Square body telescope93
Square body collimator93

ACCESSORIES94 Clamp fixtures94 Mirrors/accessories .100
Adjustable holders . .96 AC-test-wedge102
Stands96 Pentagon prism102
AC-finder prism97 Polygon mirrors104
Alignment aids98 Prisms104
Supporting flanges . .99 TV-attachment106
Attachm. achromats . .99 Software106

INTRODUCTION

Collimators, testing telescopes, autocollimators and alignment systems are indispensable for the optical workshop. Principal field of applications stretches apart from measurement of angles, quality test of optical systems up to measurement of optical surfaces radii.

MÖLLER-WEDEL OPTICAL collimators, telescopes and autocollimators are internationally recognised at scientific institutes and leading manufactures of mechanical and optical engineering. This success story is based on the high quality standards and on a well engineered and modular system. The perfect alignment, the choice of excellent materials and a restrictive quality control grant MÖLLER-WEDEL OPTICAL products nearly unlimited lifetime even in rough environmental conditions.

This catalogue is thought as an inspiration for you and as a guide for finding solutions for your specific problems. Of course you are welcome to phone, fax, or e-mail us and to give us the opportunity to advice you in detail about any of our products or to discuss your specific measurement problem.

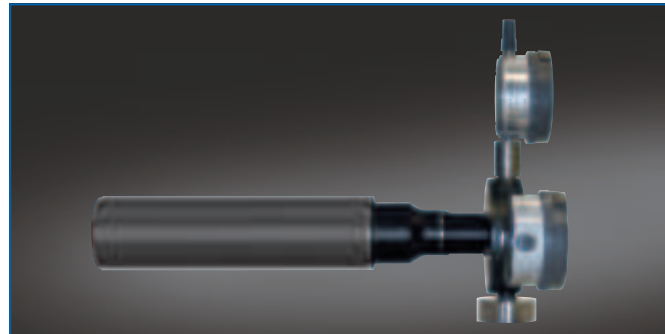

■ Testing Telescopes

In testing telescopes a reticle is mounted in the focal plane of the objective.

Testing telescopes in combination with collimators are the ideal test equipment for optical components and systems, especially for fast testing of tilt and alignment.

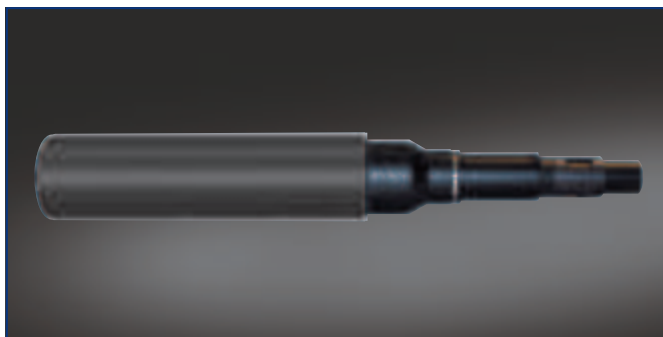

■ Collimators

Collimators are projecting a reticle to infinity. Therefore they are very important for testing and adjusting of optical components and instruments. In combination with a testing telescope many applications like alignment of tilt and direction can be covered.



■ Autocollimators

An autocollimation telescope (autocollimator) combines the function of a collimator and a telescope in one unit. In this way you get an universal tool for measuring a great many of optical and mechanical parameters like tilt- and wedge angle, resolution, radii, straightness, squareness, flatness, etc..

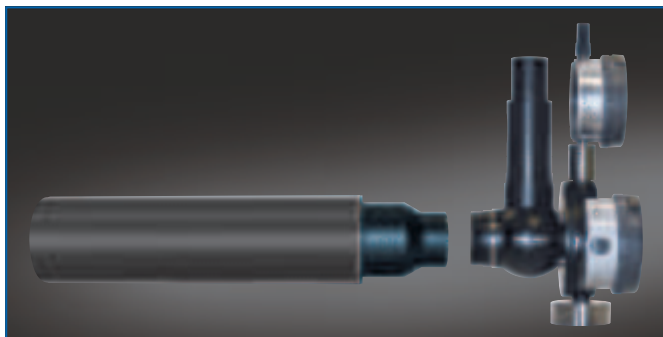

■ Modules

Because MÖLLER-WEDEL OPTICAL equipment is based on a modular concept, components are easy exchangeable without realignment. By these various combinations of modules can be realised, enabling us to deliver good valued customer solutions.



■ Alignment systems

Alignment telescopes are precision instruments for the alignment of objects on a reference line, which is defined by the line of sight of the system. This property makes them an indispensable tool for the alignment of bore holes and bearings. Beside alignment telescopes we offer alignment collimators and autocollimators. The alignment autocollimator offers the additional possibility of measuring the tilt angle of the target with respect to the reference axis.

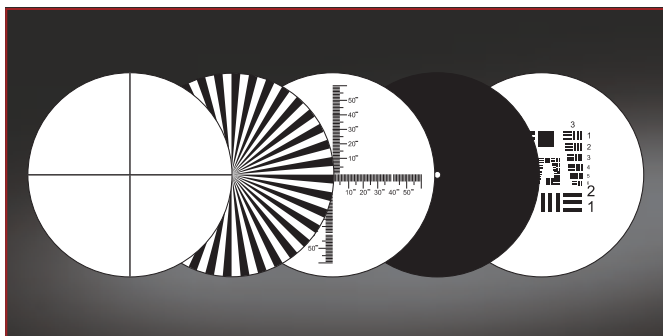

■ Reticles

MÖLLER-WEDEL OPTICAL offers reticles covering the whole range of applications like adjustment of reference marks, direct angle measurement, resolution, centration, etc..

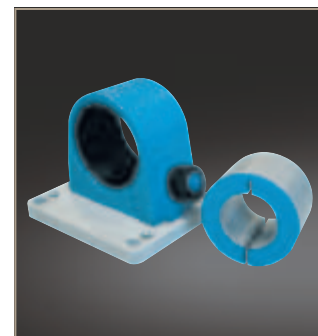

■ Other Instruments

Beside the standard applications there are instruments available for special tasks. Here you will find diopter-, reading-, square body telescopes, square body collimator and dynameter.

■ Accessories

In order to get your complete system out of one hand, MÖLLER-WEDEL OPTICAL offers a broad range of optimal tuned accessories like holders, mirrors, adapter lenses, reticles, targets and TV-equipment.

COLLIMATORS

Introduction

Layout and principle of operation

A collimator projects a reticle to a certain distance. Usually the image is at infinity at a wavelength of 546 nm.

The main components of a collimator are:

- objective tube with objective
- reticle sleeve with reticle, condenser and illumination

The following figure shows the principle set-up of a collimator adjusted to infinity. The reticle is illuminated by an illumination system consisting of a condenser and light source. The reticle is positioned at the front focal point of the objective. Due to this configuration all light beams passing a point in the reticle plane form a parallel light bundle behind the objective.

There is not a real image of the reticle. To get a real image an additional lens, for example a telescope objective, is required.

Mechanical and optical axes of collimators with focal length f 300 mm are adjusted with an accuracy of $\pm 30 \mu\text{m} / f$.

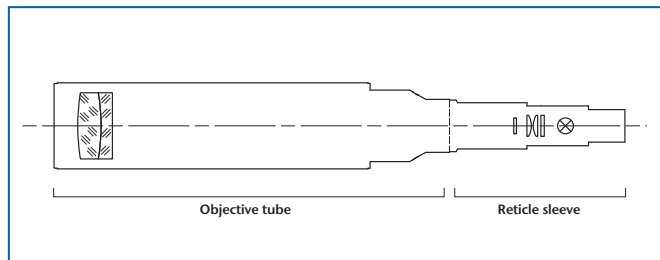

A measuring unit for tilt angles can be built by combination of a collimator with a telescope, when there is a need to measure in transmission.

Calculation of the angles

The angles (α_x and α_y) of the parallel beam of a collimator adjusted to infinity in respect to its optical axes can be calculated as follows:

$$\alpha_x = \arctan\left(\frac{\Delta X}{f}\right) \quad \frac{\Delta X}{f}$$

$$\alpha_y = \arctan\left(\frac{\Delta Y}{f}\right) \quad \frac{\Delta Y}{f}$$

f : focal length of the collimator objective

ΔX : displacement of a point in X-direction

ΔY : displacement of a point in Y-direction

Numerical example:

A point with 3 mm distance from the reticle center of a collimator with 300 mm focal length is imaged at an angle of:

$$\alpha \quad 3/300 \text{ rad} = 10 \cdot 10^{-3} \text{ rad} = 0,5730^\circ = 34'23''$$

A displacement of $10 \mu\text{m}$ from the centre of collimator reticle is calculated to have the following angle for the different focal length.

Focal length	Angle
50 mm	41"
90 mm	23"
140 mm	15"
200 mm	10"
300 mm	6,9"
500 mm	4,1"
600 mm	3,4"
1100 mm	1,9"



Adjustable Focus

Collimators with adjustable focus are available in addition to those with fixed focus. Adjustable focus collimators vary the distance between reticle and objective.

If the reticle is displaced from the focal plane by a distance z , then the collimator is focused at a distance a' according to:

$$a' = \frac{f^2 + zf}{z}$$

$z < 0$ corresponds to a decrease of the distance between objective and reticle. The resulting image distance is negative (virtual object position) (a).

$z > 0$ corresponds to a real image with positive object distance (c).

$z = 0$ produces an image at infinite distance (b).

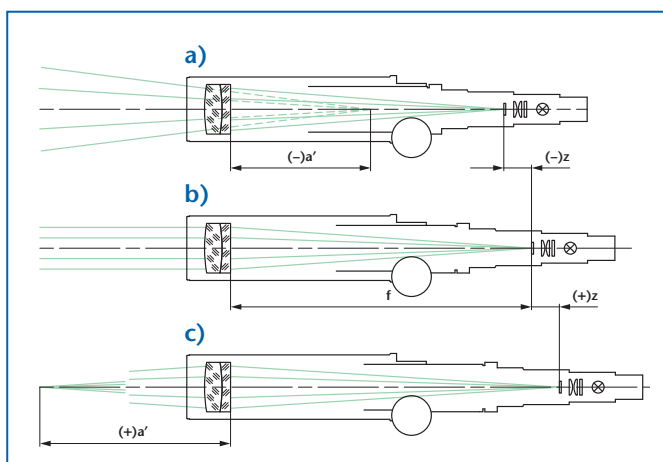

Selection criteria

Long or short focal length?

A longer focal length leads to small field angles. As the focal length increases the field of view decreases proportionally. For resolution testing choose a collimator with equal or slightly larger focal length than the optics under test. When used in conjunction with a testing telescope choose the same focal length. Additionally, the intensity of the light bundle emitted from the collimator decreases with increased focal length. A longer focal length affects the mechanical extension of the tube, as well.

Small or large objective aperture?

Light conditions are more favourable when large apertures are used, and the evaluation of the results is easier and more accurate. A long distance between test specimen and collimator demands a relatively large clear aperture (or aperture ratio). For these measurements a relatively large aperture diameter should be used.

Fixed or variable distance setting?

Fixed, infinity focus collimators are generally the best choice when testing systems adjusted to infinity. Fixed focus tubes set at other than infinity can be ordered.

Measuring tasks requiring different wavelengths of light, or measurements requiring focus other than infinity are best accomplished using focusable collimators.

COLLIMATORS

Description:

For a general description of the operating principle of collimators see page 6.

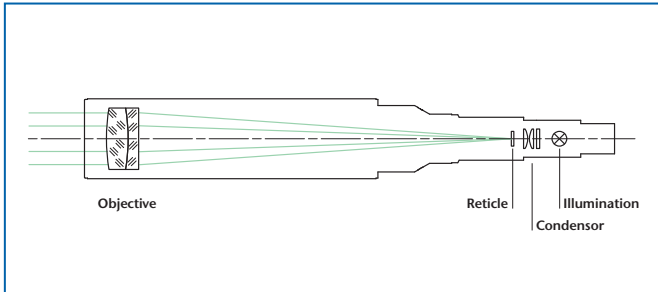

Application examples:

- Measurement of angular displacements (in conjunction with a telescope)
- Testing of the infinity setting of camera objectives
- Testing of the imaging properties of optical elements and systems

Notes on ordering:

- One reticle, 6V/5W illumination w/cord are included in the delivery.
- If not specified otherwise, the collimator is adjusted to infinity at 546 nm wavelength. Adjustment to other distances or wavelengths is also possible on demand.
- The nomenclature of the collimators is as follows:

Example: **K 50/ 40**

Collimator — K
Focal length — 50
Tube diameter — 40

Important:

Please specify the reticle (see page 82) and illumination (LED-, bulb- or cold light, see page 81) when ordering.

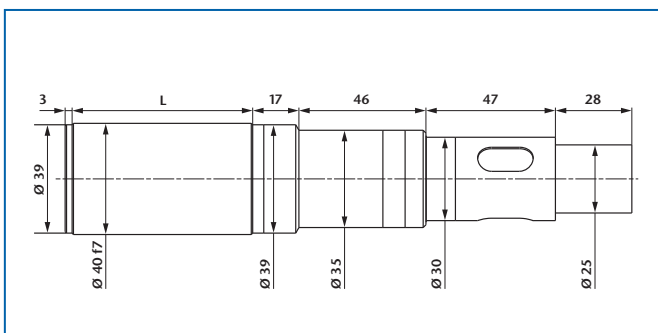

Ord.-No.	Description	Focal length	clear aperture	Field of view	L
225 004	K 50/40	50	10	10,0°	65
225 005	K 90/40	90	16	6,0°	65
225 006	K 140/40	140	28	4,0°	118
225 007	K 200/40	200	28	3,0°	173
225 008	K 300/40	300	28	2,0°	274
225 009	K 500/40	500	28	1,0°	474



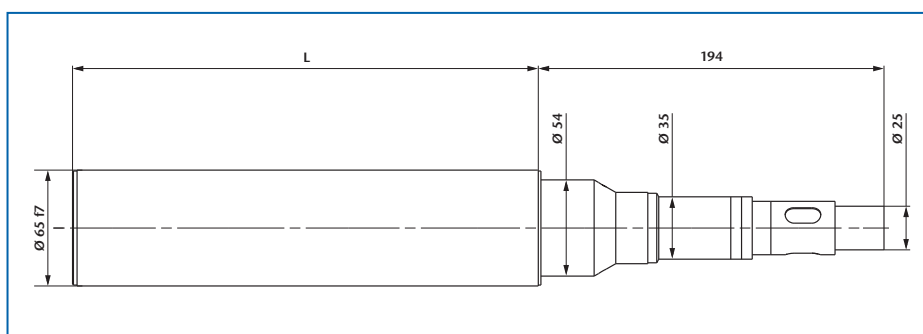

Ord.-No.	Description	Focal length	clear aperture	Field of view	L
225 010	K 300/65	300	50	2,0°	233
225 011	K 500/65	500	50	1,0°	415
225 012	K 500T/65	500	50	1,0°	233

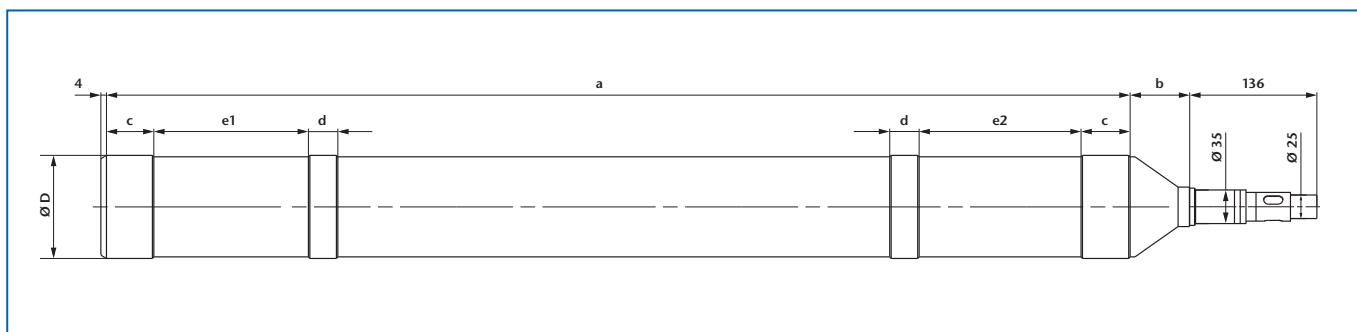

Ord.-No.	Description	Focal length	clear aperture	Field of view	D	a	b	c	d	e1	e2
225 015	K 600/128	600	100	0,8°	Ø 128 f7	530	46	-	58	154	78
225 016	K 1100/105	1100	78	0,5°	Ø 105 f7	1045	66	50	30	165	100

COLLIMATORS WITH RETICLE TURRET

Description:

For a general description of the operating principle of collimators see page 6.

A collimator with a reticle turret provides 6 selectable collimator reticles. The reticle turret allows a quick change of reticles for different measurement tasks.

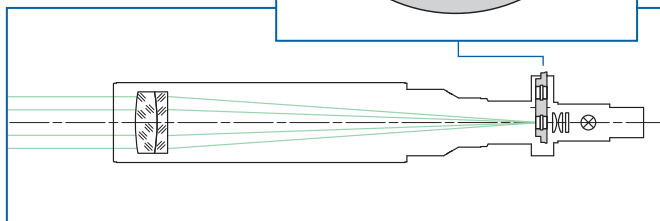
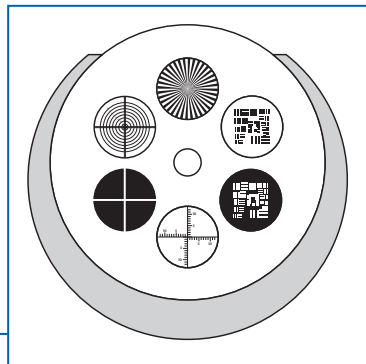

Application areas:

- Measurement of angular tilt (in conjunction with a telescope)
- Testing of the infinity setting of camera objectives
- Qualitative testing of the imaging properties of optical elements and systems

Notes on ordering:

- Six reticles and 6V/5W illumination w/cord are included.
- In contrast to collimators with one reticle the optical axis of the collimator with reticle turret can not be adjusted to be co-linear with the mechanical axis.
- If not specified otherwise, the collimator is adjusted to infinity at 546 nm wavelength. Adjustment to other distances or other wavelengths is also possible on demand.
- The nomenclature of the collimators with reticle turret is as follows:

Example: **K 50/ 40 SW**

Collimator — K
Focal length — 50
Tube diameter — 40
Reticle turret — SW

Important:

Please specify the reticle (see page 82) and illumination (LED-, bulb- or cold light, see page 81) when ordering.

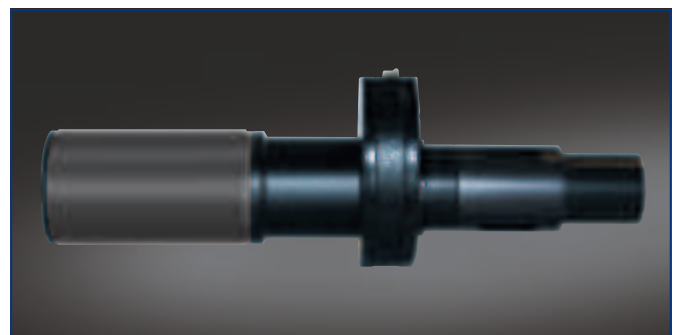
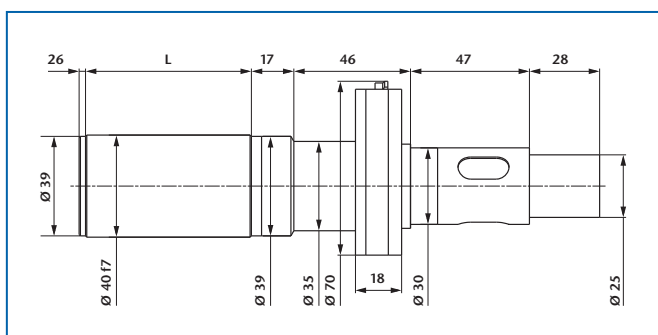

Ord.-No.	Description	Focal length	clear aperture	Field of view	L
225 201	K 50/40 SW	50	10	10,0°	65
225 202	K 90/40 SW	90	16	6,0°	65
225 203	K 140/40 SW	140	28	4,0°	118
225 204	K 200/40 SW	200	28	3,0°	173
225 205	K 300/40 SW	300	28	2,0°	274
225 206	K 500/40 SW	500	28	1,0°	474

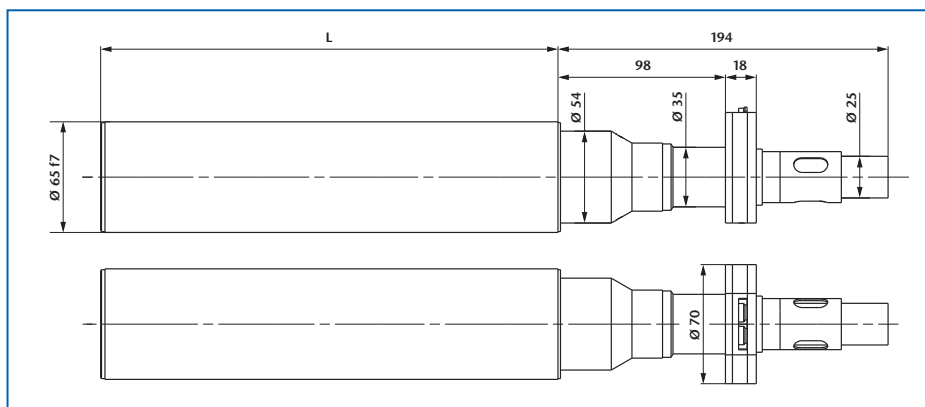
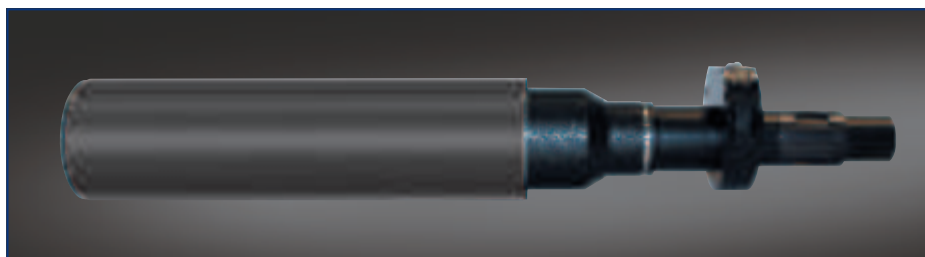

Ord.-No.	Description	Focal length	clear aperture	Field of view	L
225 207	K 300/65 SW	300	50	2,0°	233
225 208	K 500/65 SW	500	50	1,0°	415
225 209	K 500T/65 SW	500	50	1,0°	233

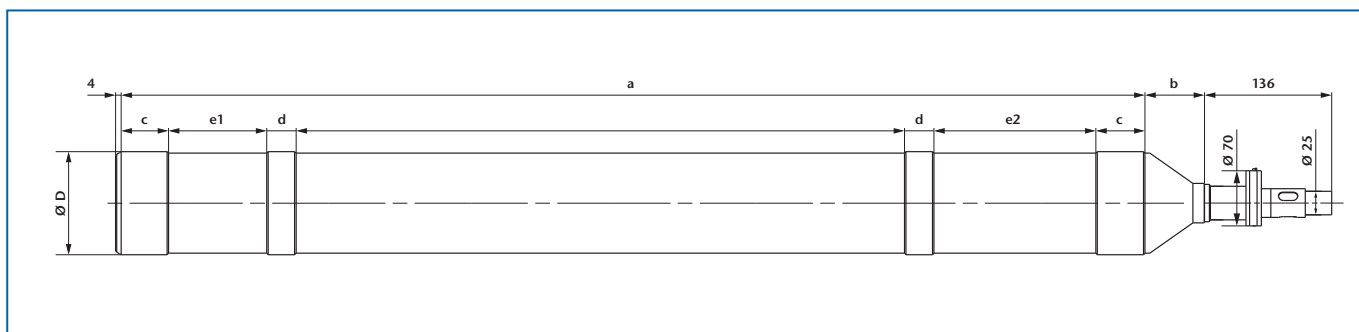
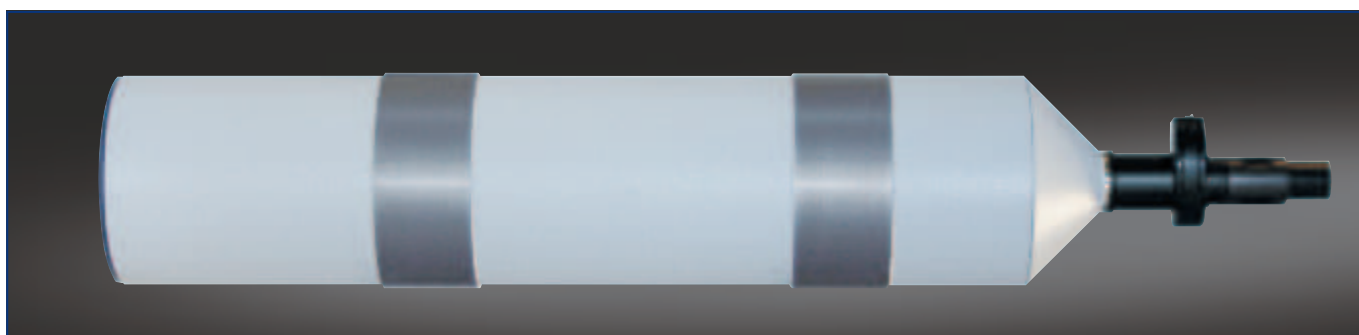

Ord.-No.	Description	Focal length	clear aperture	Field of view	D	a	b	c	d	e1	e2
225 212	K 600/128 SW	600	100	0,8°	Ø 128 f7	530	46	-	58	154	78
225 213	K 1100/105 SW	1100	78	0,5°	Ø 105 f7	1045	66	50	30	165	100

COLLIMATORS WITH DOUBLE MICROMETER

Description:

For a general description of the operating principle of collimators see page 6.

A collimator with double micrometer allows the setting of defined image angles in two directions.

The movement of the reticle in x- and y-direction in the focal plane is measured with measuring drums. The scale division (SD) is 5 μm .

Application areas:

- Measurement of angular tilt (in conjunction with a telescope)
- Qualitative testing of the imaging properties of optical elements and systems

Notes on ordering:

- One reticle and 6V/5W illumination w/cord are included.
- If not specified otherwise, the collimator is adjusted to infinity at 546 nm wavelength. Adjustment to other distances or other wavelengths is also possible on demand.
- The nomenclature of the collimators with double micrometer is as follows:

Example: **K 50/ 40 MD**

Collimator ———
Focal length ———
Tube diameter ———
Double micrometer ———

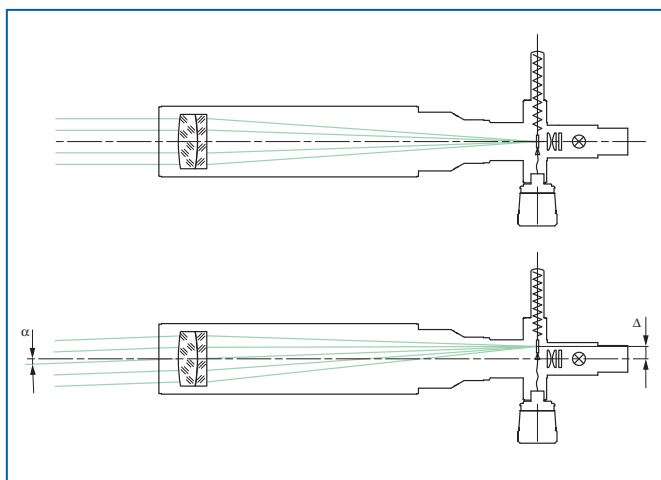

Important:

Please specify the reticle (see page 82) and illumination (LED-, bulb- or cold light, see page 81) when ordering.

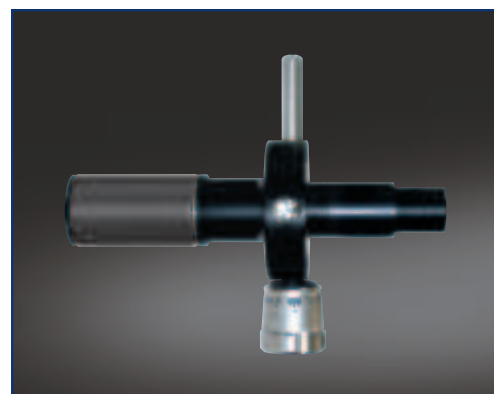
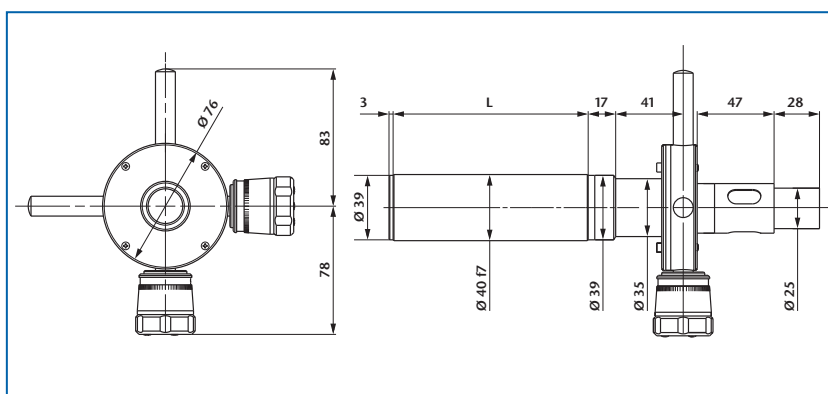

Ord.-No.	Description	Focal length	clear aperture	Setting range	SD	L
225 281	K 50/40 MD	50	10	3,2°	20,0"	65
225 282	K 90/40 MD	90	16	2,0°	11,5"	65
225 283	K 140/40 MD	140	28	1,2°	7,5"	118
225 284	K 200/40 MD	200	28	0,8°	5,0"	173
225 285	K 300/40 MD	300	28	0,6°	3,5"	274
225 286	K 500/40 MD	500	28	0,4°	2,0"	474

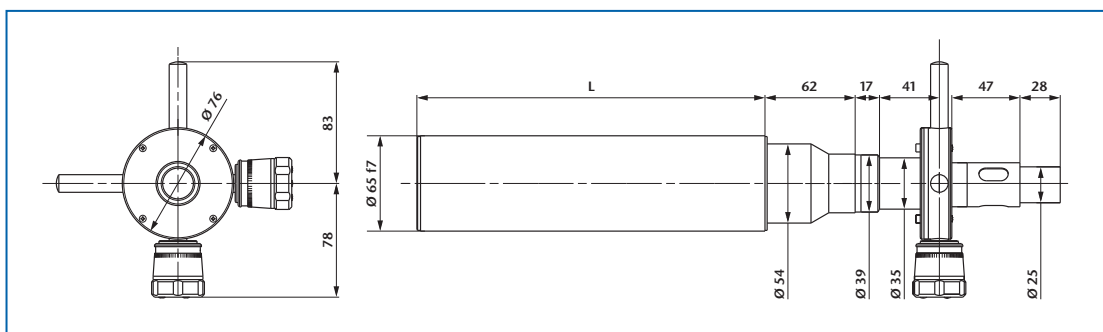
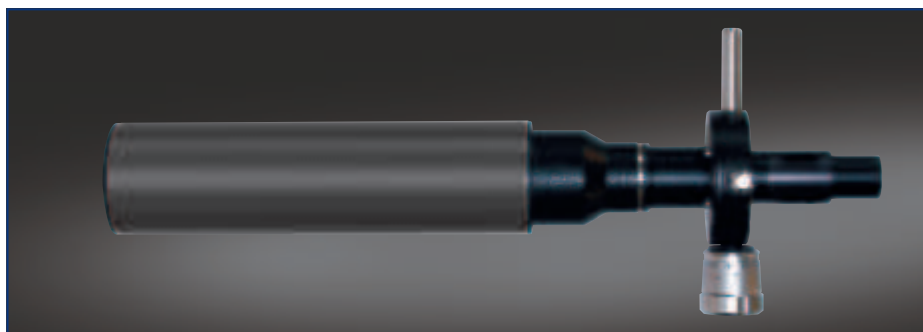

Ord.-No.	Description	Focal length	clear aperture	Setting range	SD	L
225 287	K 300/65 MD	300	50	0,6°	3,5"	233
225 288	K 500/65 MD	500	50	0,4°	2,0"	415
225 289	K 500T/65 MD	500	50	0,4°	2,0"	233

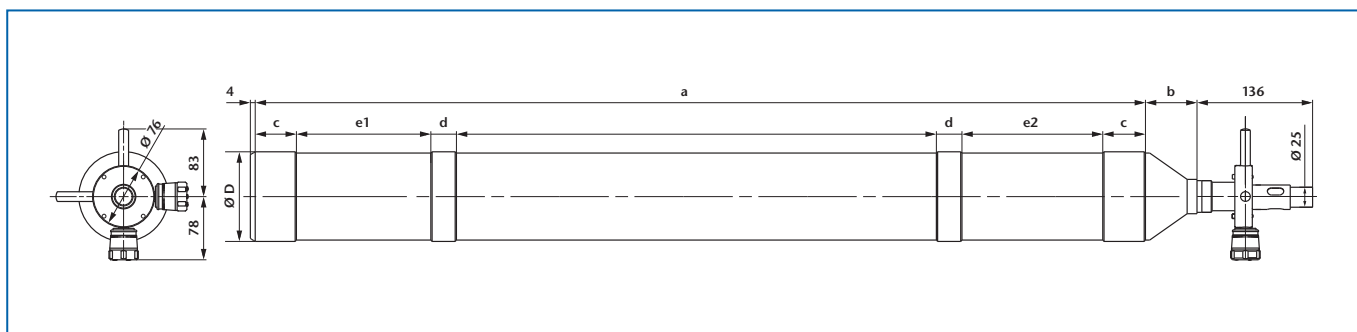
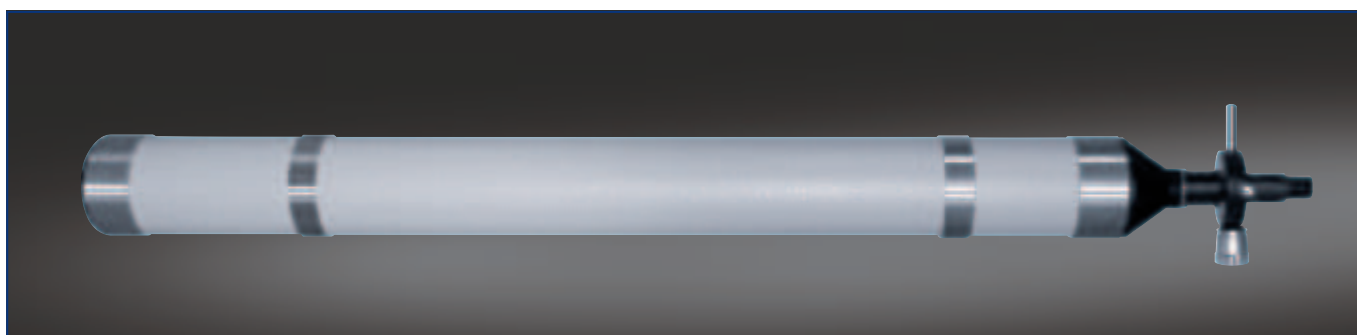

Ord.-No.	Description	Focal length	clear aperture	Setting range	SD	D	a	b	c	d	e1	e2
225 292	K 600/128 MD	600	100	0,30°	1,7"	Ø 128 f7	530	46	-	58	154	78
225 293	K 1100/105 MD	1100	78	0,16°	1,0"	Ø 105 f7	1045	66	50	30	165	100

COLLIMATORS

FOCUS ADJUSTABLE

Description:

For a general description of the operating principle of collimators see page 6.

An adjustable focus collimator allows the distance between reticle and collimation objective to be adjusted for measurements made at other than infinity. Additionally, infinity can be set for different wavelengths of light.

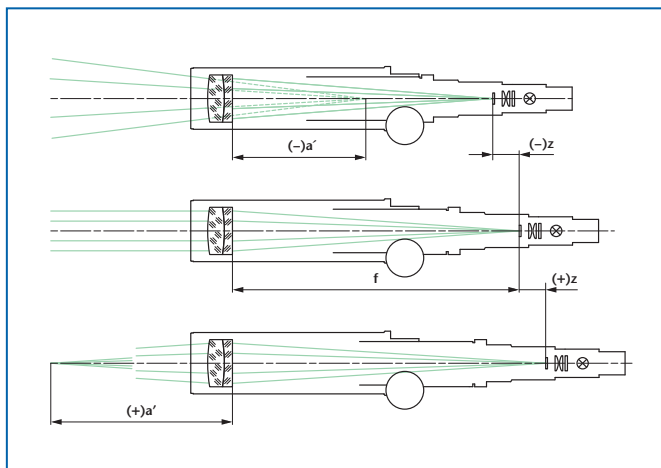

Application areas:

- Testing of distance setting of optical instruments
- Adjustment at different wavelengths of light

Notes on ordering:

- One reticle and 6V/5W illumination w/cords are included.
- The nomenclature of the adjustable focus collimators is as follows:

Example: K V 90/ 40/ ±6

Collimator — K
 Variable — V
 Focal length — 90/
 Tube diameter — 40/
 Tube extension in mm — ±6

Important:

Please specify the reticle (see page 82) and illumination (LED-, bulb- or cold light, see page 81) when ordering.

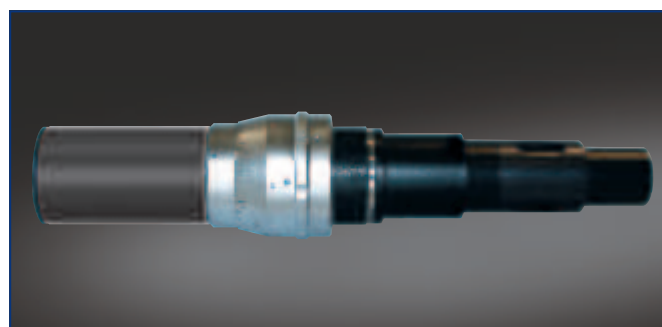
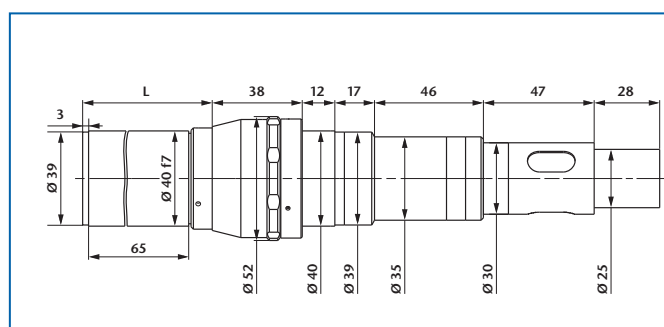

Ord.-No.	Description	Focal length	Free aperture	Tube extension	Field of view	Distance range	L
225 501	KV 90/40/±6	90	16	±6	6,0°	- ...-1,25 m 1,40 m...+	77±6
225 502	KV 90/40/+12	90	16	+12	6,0°	0,80 m...+	71 ⁺¹²
225 503	KV 90/40/-12	90	16	-12	6,0°	- ...-0,60 m	83 ⁻¹²
225 504	KV 140/40/±6	140	28	±6	4,0°	- ...-3,10 m 3,30 m...+	77±6
225 505	KV 140/40/+12	140	28	+12	4,0°	1,70 m...+	71 ⁺¹²
225 506	KV 140/40/-12	140	28	-12	4,0°	- ...-1,40 m	83 ⁻¹²

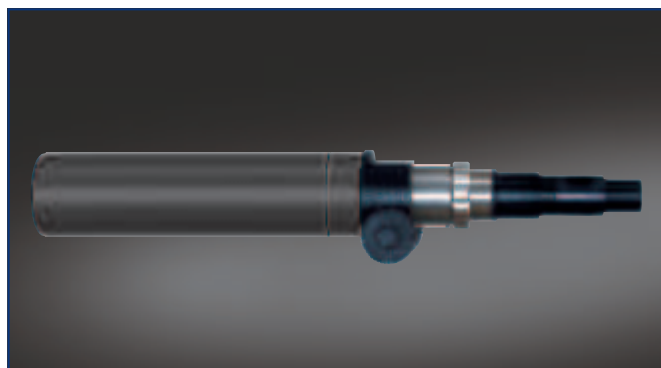
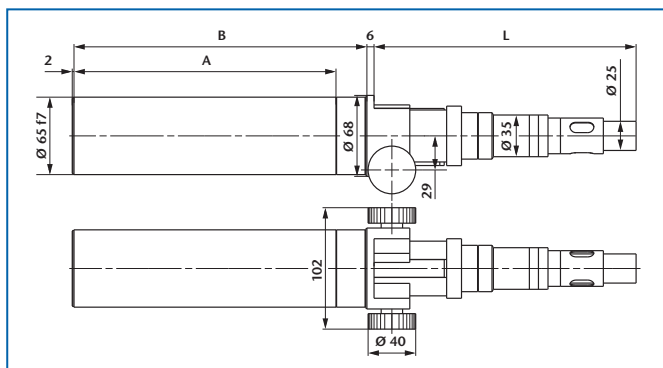

Ord.-No.	Description	Focal length	clear aperture	Tube extension	Field of view	Distance range	A	B	L
225 507	KV 300/65/±25	300	50	±25	2,0°	- ...-3,4 m 3,8 m...+	220	245	220±25
225 508	KV 300/65/+50	300	50	+50	2,0°	2,1 m...+	220	270	195 ⁺⁵⁰
225 509	KV 300/65/-50	300	50	-50	2,0°	- ...-1,5 m	220	220	245 ⁻⁵⁰
225 510	KV 500/65/±50	500	50	±50	1,0°	- ...-4,5 m 5,4 m...+	310	360	245±50
225 511	KV 500/65/+100	500	50	+100	1,0°	3,0 m...+	310	410	195 ⁺¹⁰⁰
225 512	KV 500/65/-100	500	50	-100	1,0°	- ...-1,5 m	310	310	295 ⁻¹⁰⁰

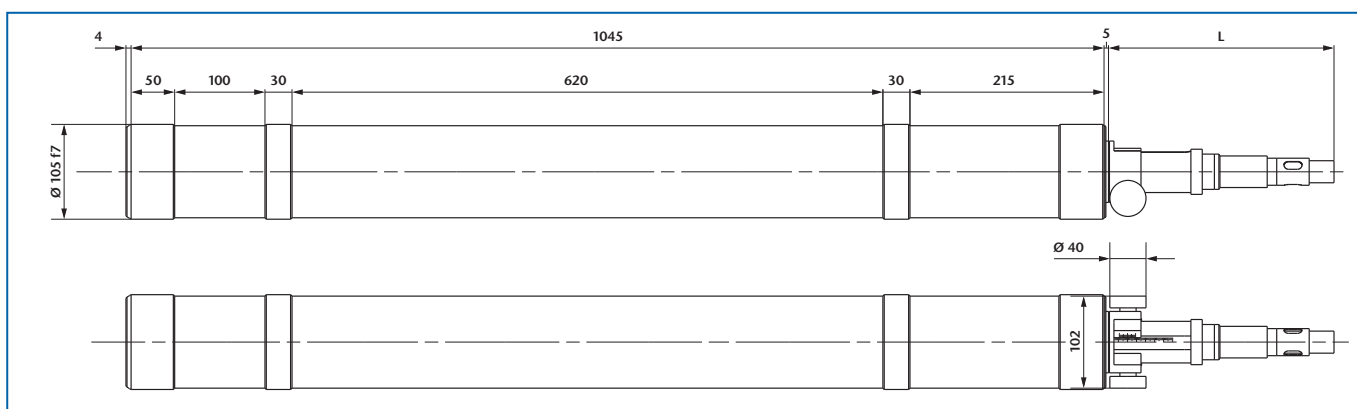
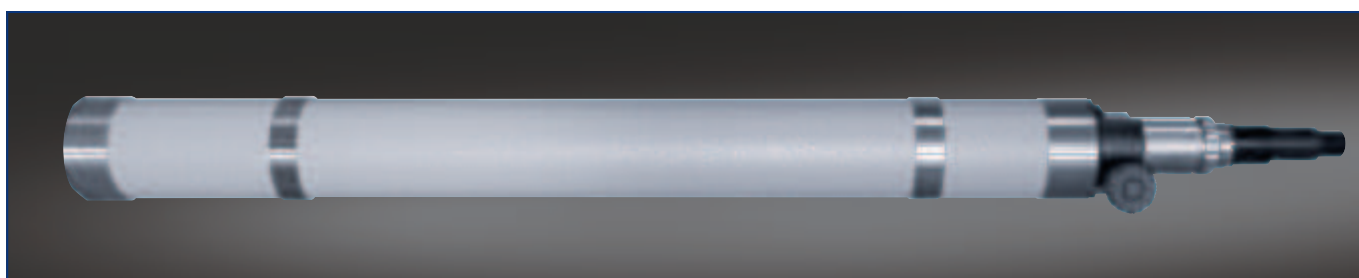

Ord.-No.	Description	Focal length	Free aperture	Tube extension	Field of view	Distance range	L
225 516	KV 1100/105/±50	1100	78	±50	0,5°	- ...-23,70 m 25,80 m...+	250±50
225 517	KV 1100/105/+100	1100	78	+100	0,5°	13,20 m...+	250 ⁺¹⁰⁰
225 518	KV 1100/105/-100	1100	78	-100	0,5°	- ...-12,00 m	250 ⁻¹⁰⁰

COLLIMATORS

FOCUS ADJUSTABLE – WITH RETICLE TURRET

Description:

For a general description of the operating principle of collimators see page 6.

An adjustable focus collimator with reticle turret provides 6 selectable collimator reticles and allows the distance between reticle and collimation objective to be adjusted for measurements made at other than infinity. Additionally, infinity can be set for different wavelengths of light.

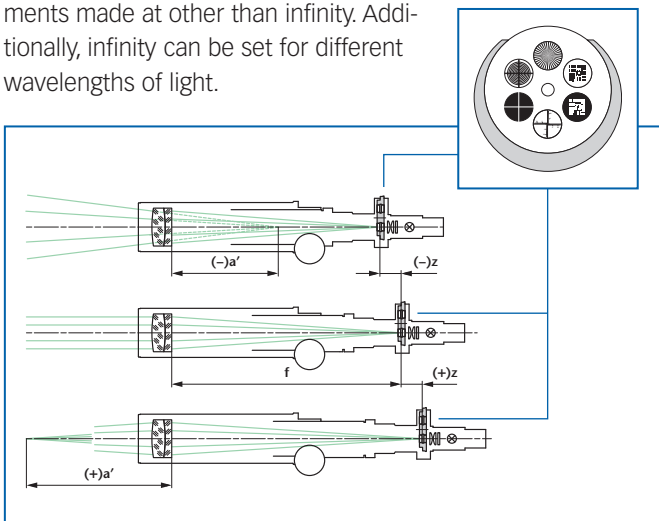

Notes on ordering:

- Six reticles and 6V/5W illumination w/cord are included.
- The nomenclature of the adjustable focus collimators with reticle turret is as follows:

Example: K V 90/ 40/ ±6 SW

Collimator — K
 Variable — V
 Focal length — 90/
 Tube diameter — 40/
 Tube extension — ±6
 Reticle turret — SW

Important:

Please specify the reticle (see page 82) and illumination (LED-, bulb- or cold light, see page 81) when ordering.

Application areas:

- Testing of distance setting of optical instruments
- Adjustment at different wavelengths of light

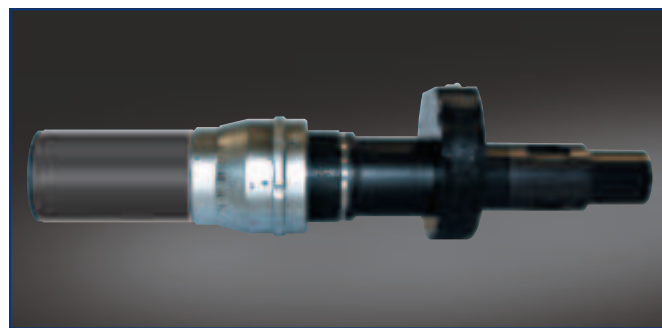
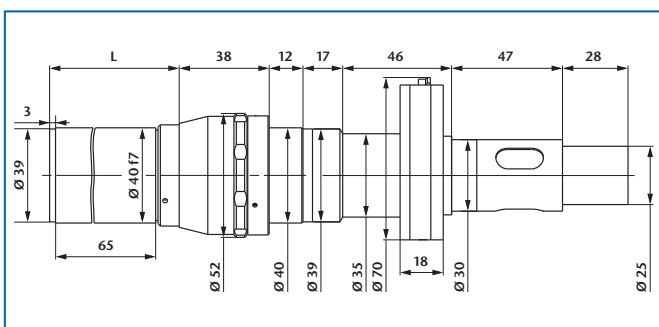

Ord.-No.	Description	Focal length	Free aperture	Tube extension	Field of view	Distance range	L
225 701	KV 90/40/±6 SW	90	16	±6	6,0°	- ...-1,25 m 1,40 m...+	77±6
225 702	KV 90/40/+12 SW	90	16	+12	6,0°	0,80 m...+	71 ⁺¹²
225 703	KV 90/40/-12 SW	90	16	-12	6,0°	- ...-0,60 m	83 ⁻¹²
225 704	KV 140/40/±6 SW	140	28	±6	4,0°	- ...-3,10 m 3,30 m...+	77±6
225 705	KV 140/40/+12 SW	140	28	+12	4,0°	1,70 m...+	71 ⁺¹²
225 706	KV 140/40/-12 SW	140	28	-12	4,0°	- ...-1,40 m	83 ⁻¹²

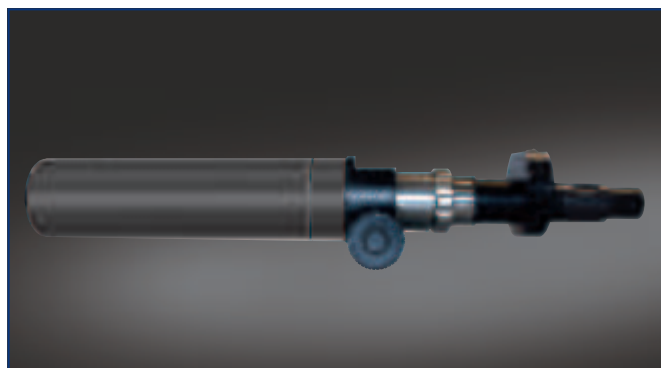
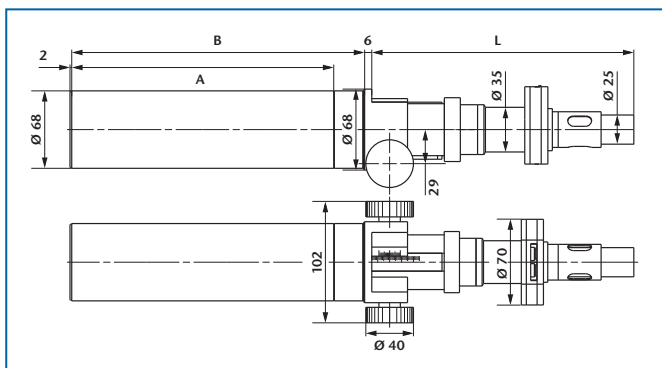

Ord.-No.	Description	Focal length	clear aperture	Tube extension	Field of view	Distance range	A	B	L
225 707	KV 300/65/±25 SW	300	50	±25	2,0°	- ...-3,4 m 3,8 m...+	220	245	220±25
225 708	KV 300/65/+50 SW	300	50	+50	2,0°	2,1 m...+	220	270	195 ⁺⁵⁰
225 709	KV 300/65/-50 SW	300	50	-50	2,0°	- ...-1,5 m	220	220	245 ⁻⁵⁰
225 710	KV 500/65/±50 SW	500	50	±50	1,0°	- ...-4,5 m 5,4 m...+	310	360	245±50
225 711	KV 500/65/+100 SW	500	50	+100	1,0°	3,0 m...+	310	410	195 ⁺¹⁰⁰
225 712	KV 500/65/-100 SW	500	50	-100	1,0°	- ...-1,5 m	310	310	295 ⁻¹⁰⁰

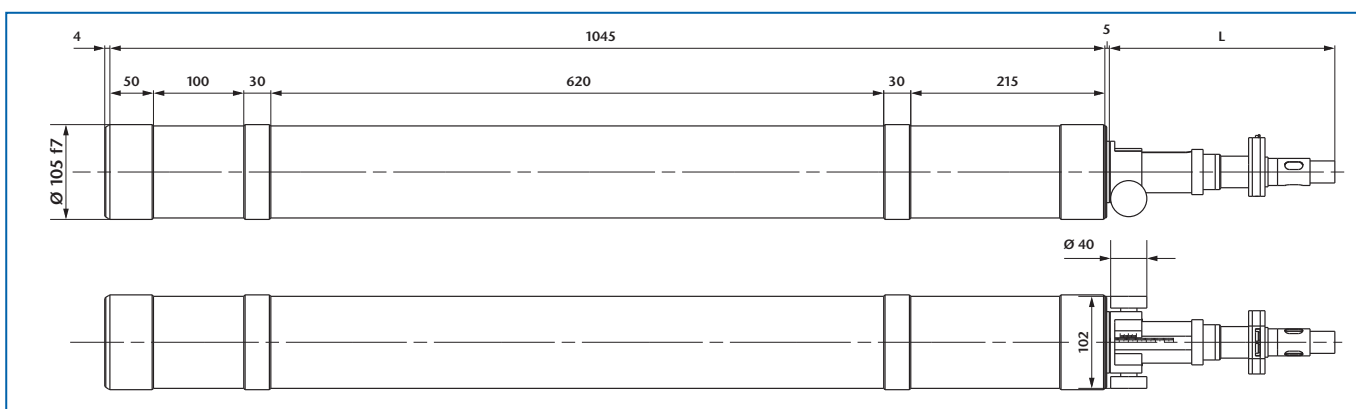
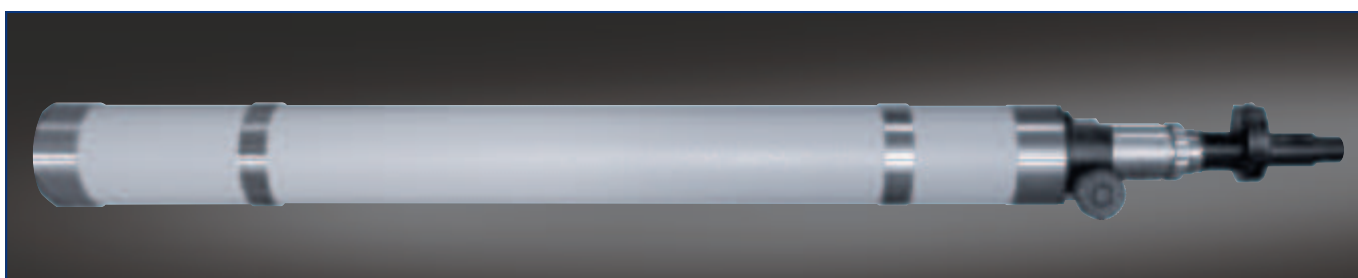

Ord.-No.	Description	Focal length	Free aperture	Tube extension	Field of view	Distance range	L
225 716	KV 1100/105/±50 SW	1100	78	±50	0,5°	- ...-23,70 m 25,80 m...+	250±50
225 717	KV 1100/105/+100 SW	1100	78	+100	0,5°	13,20 m...+	250 ⁺¹⁰⁰
225 718	KV 1100/105/-100 SW	1100	78	-100	0,5°	- ...-12,00 m	250 ⁻¹⁰⁰

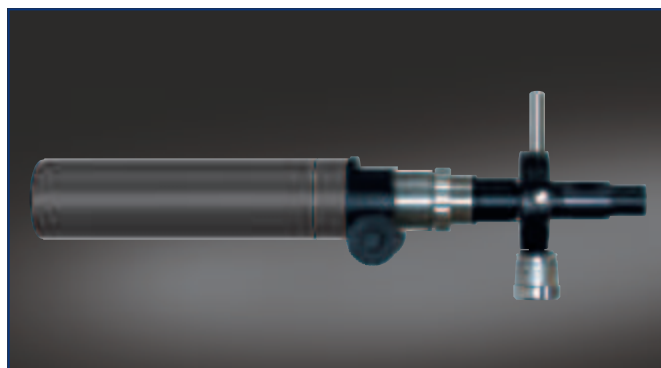
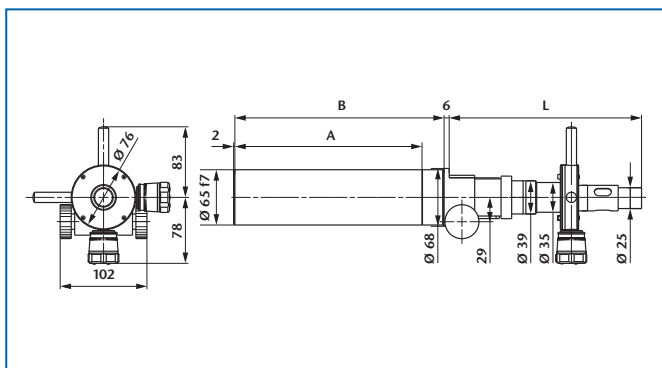

Ord.-No.	Description	Focal length	clear aperture	Tube extension	Setting range	SD	Distance range	A	B	L
225 807	KV 300/65/±25 MD	300	50	±25	0,6°	3,5"	- ...-3,4 m 3,8 m...+	220	245	220±25
225 808	KV 300/65/+50 MD	300	50	+50	0,6°	3,5"	2,1 m...+	220	270	195 ⁺⁵⁰
225 809	KV 300/65/-50 MD	300	50	-50	0,6°	3,5"	- ...-1,5 m	220	220	245 ⁻⁵⁰
225 810	KV 500/65/±50 MD	500	50	±50	0,4°	2,0"	- ...-4,5 m 5,4 m...+	310	360	245±50
225 811	KV 500/65/+100 MD	500	50	+100	0,4°	2,0"	3,0 m...+	310	410	195 ⁺¹⁰⁰
225 812	KV 500/65/-100 MD	500	50	-100	0,4°	2,0"	- ...-1,5 m	310	310	295 ⁻¹⁰⁰

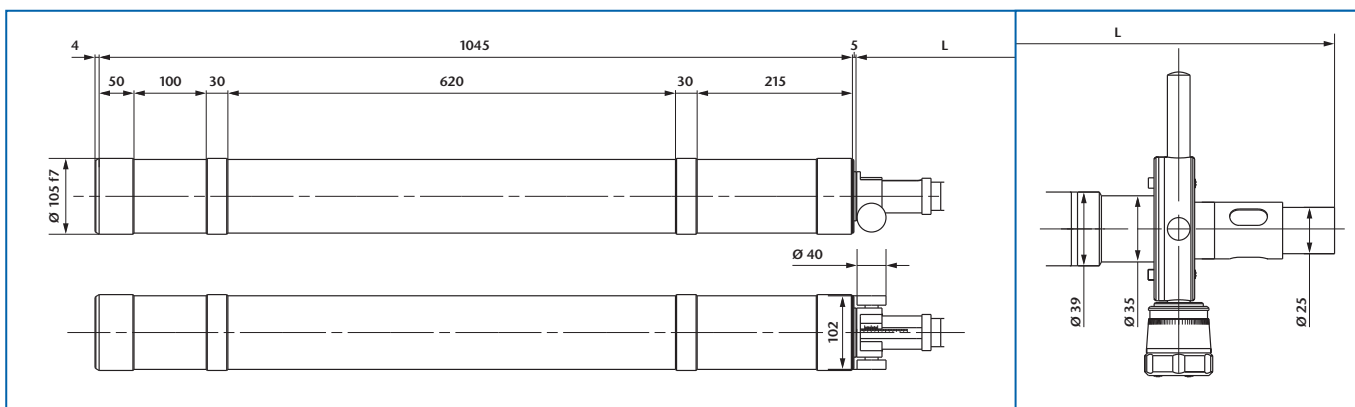

Ord.-No.	Description	Focal length	Free aperture	Tube extension	Setting range	SD	Distance range	L
225 816	KV 1100/105/±50 MD	1100	78	±50	0,16°	1,0"	- ...-23,70 m 25,80 m...+	250±50
225 817	KV 1100/105/+100 MD	1100	78	+100	0,16°	1,0"	13,20 m...+	250 ⁺¹⁰⁰
225 818	KV 1100/105/-100 MD	1100	78	-100	0,16°	1,0"	- ...-12,00 m	250 ⁻¹⁰⁰

TESTING TELESCOPES

INTRODUCTION

Layout and principle of operation

A testing telescope provides a magnified real image of a distant object. Usually the object is at infinity at a wavelength of 546 nm. The main components of a testing telescope are:

- objective tube with objective
- reticle sleeve with reticle
- eyepiece

The following figure shows the principle set-up of a testing telescope with straight viewing adjusted to infinity. The reticle is positioned at the rear focal plane of the objective. Due to this configuration all objects at infinity are imaged into the reticle plane. The reticle plane is viewed through the eyepiece. Due to this set-up the image in the eyepiece is rotated by 180°.

Mechanical and optical axes of testing telescopes with focal length f 300 mm are adjusted with an accuracy of $\pm 30 \mu\text{m} / f$.

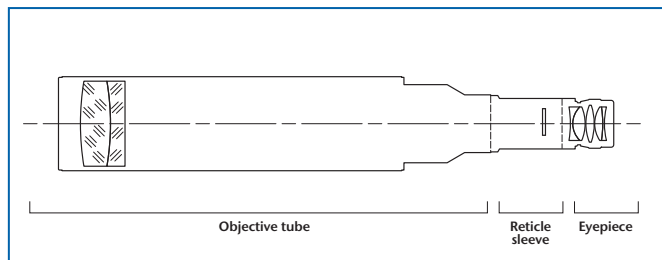

Testing telescopes form with collimators a measuring system for direction and angle testing of optical elements or optical systems in transmission.

Calculation of the angles

The angles (α_x and α_y) can be calculated from the distances Δx or Δy of the image of the collimator reticle to zero position of the eyepiece reticle as follows:

$$\alpha_x = \arctan\left(\frac{\Delta x}{f}\right) \quad \frac{\Delta x}{f}$$

$$\alpha_y = \arctan\left(\frac{\Delta y}{f}\right) \quad \frac{\Delta y}{f}$$

f : focal length of the telescope objective

Numerical example:

A displacement of 3 mm measured with a testing telescope with 300 mm focal length corresponds to an angle of:

$$\alpha \quad 3/300 \text{ rad} = 10 \cdot 10^{-3} \text{ rad} = 0,5730^\circ = 34'23''$$

A point at a distance of 10 μm to the centre of the eyepiece reticle corresponds to an angle of the parallel beam to the optical axis of the telescope as follows:

Focal length	Angle
50 mm	41"
90 mm	23"
140 mm	15"
200 mm	10"
300 mm	6,9"
500 mm	4,1"
600 mm	3,4"
1100 mm	1,9"



Adjustable Focus

Besides testing telescopes with fixed distance between reticle and objective telescopes with adjustable focus are available. With these telescopes the distance between reticle and objective is adjustable.

If the reticle is displaced out of the focal plane by a distance z' , then the telescope is focused at a distance a according to:

$$a = \frac{f^2 + z'f}{z'}$$

$z' < 0$ corresponds to a decrease of the distance between objective and reticle. The resulting image distance is negative (virtual object position) (a).

$z' > 0$ corresponds to a real image with positive object distance (c). $z' = 0$ produces an image at infinite distance (b).

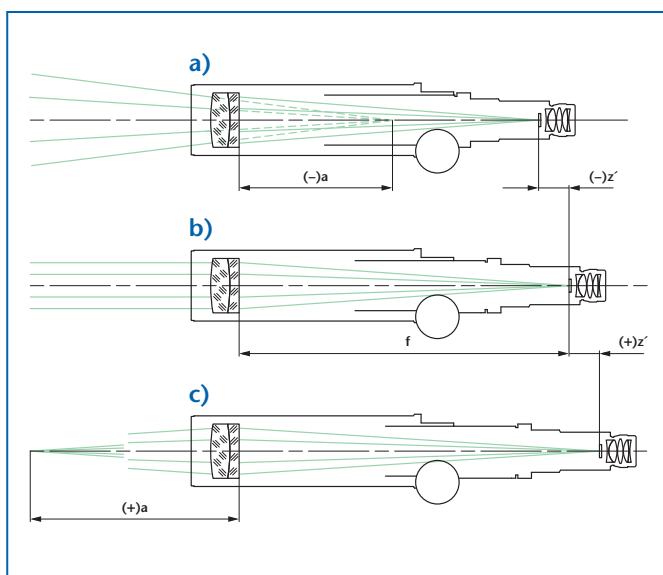

Selection criteria

Long or short focal length?

Depending on the magnification of the instrument a longer focal length leads to a greater measuring sensitivity and measurement accuracy. As the focal length increases, the measuring range (FOV) decreases proportionally. Additionally, the intensity of the light bundle received by the telescope decreases with increased focal length. A longer focal length affects the mechanical extension of the tube, as well.

Small or large objective aperture?

Light conditions are more favourable when large apertures are used, and the evaluation of the results is easier and more accurate. A long distance between test specimen and telescope demands a relatively large clear aperture (or aperture ratio). For these measurements a relatively large aperture diameter should be used.

Fixed or variable distance setting?

Fixed, infinity focus testing telescopes are generally the best choice when testing systems adjusted to infinity. Fixed focus tubes set at other than infinity can be ordered.

For measurement tasks requiring an adjustable focal distance like adjustment at different wavelengths or to different distances, focusable testing telescopes with objective tube with tube extensions are used.

Eyepiece focal length?

Usually eyepieces with $f=14,7$ mm are used. Eyepieces with $f=10$ mm give greater magnification but less field angle. Eyepieces with $f=25$ mm give larger field of view but less magnification. For eyepieces with $f=14,7$ mm and $f=25$ mm a C-Mount Camera adapter is available.

TESTING TELESCOPES

STRAIGHT VIEWING

Description:

For a general description of the operating principle of testing telescopes see page 20.

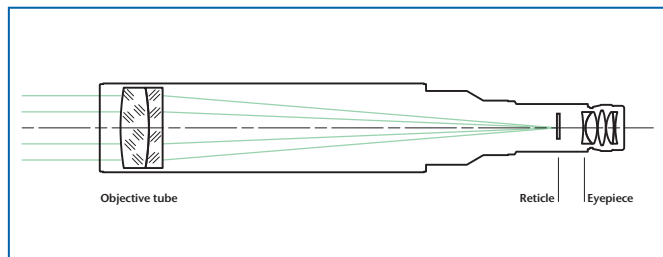

Application examples

(additional collimator required):

- Measurement of angular displacement
- Parallelism measurement of uncoated flats
- Testing of the imaging properties of optical elements and systems

Notes on ordering:

- Testing telescope eyepiece is commonly $f=14,7$ mm but can be equipped with eyepieces $f=25$ mm or $f=10$ mm on request.
- One reticle and one eyepiece are included in the standard instrument.
- If not specified otherwise, the testing telescope is adjusted to infinity at 546 nm wavelength. Adjustment to other distances or wavelengths is also possible on demand.
- The nomenclature of the testing telescopes with straight viewing is as follows:

Example: F G 50/ 40/ 14,7

Testing telescope
Straight viewing
Focal length
Tube diameter
Eyepiece focal length

Important:

Please specify reticle (see page 82) when ordering.

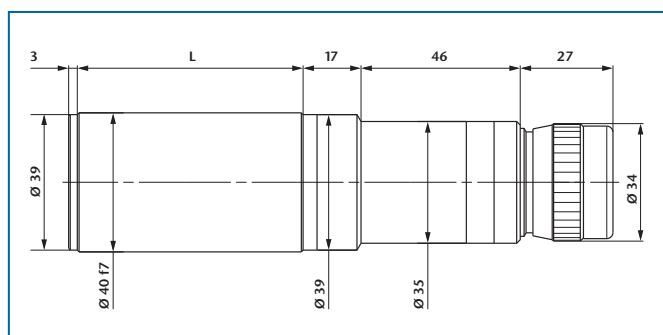

Ord.-No.	Description	Focal length	clear aperture	Field of view	L
227 004	FG 50/40/14,7	50	10	10,0°	65
227 005	FG 90/40/14,7	90	16	6,0°	65
227 006	FG 140/40/14,7	140	28	4,0°	118
227 007	FG 200/40/14,7	200	28	3,0°	173
227 008	FG 300/40/14,7	300	28	2,0°	274
227 009	FG 500/40/14,7	500	28	1,0°	474



TESTING TELESCOPES

90°-VIEWING

Description:

For a general description of the operating principle of testing telescopes see page 20.

The basic function and design of testing telescopes with 90° viewing is the same as of testing telescopes with straight viewing.

The testing telescopes with 90° viewing contain an additional folding mirror. This kind of testing telescope is used for vertical set-ups or for set-ups on optical tables where straight viewing is not practical from point of view of ergonomics and space.

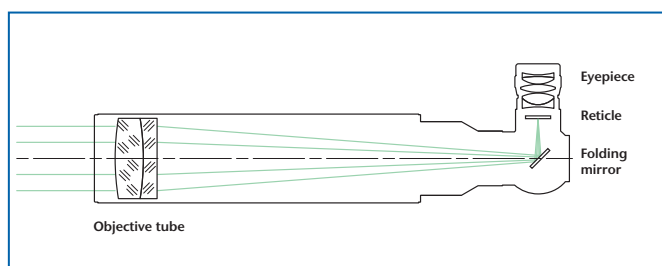

Application examples

(additional collimator required):

- Measurement of angular displacement
- Parallelism measurement of uncoated flats
- Testing of the imaging properties of optical elements and systems
- Measurement of the focal length of negative optical systems/elements (additional attachment achromat required)

Notes on ordering:

- Testing telescope eyepiece is commonly $f=14,7$ mm but can be equipped with eyepieces $f=25$ mm or $f=10$ mm on request.
- One reticle and one eyepiece are included in the standard instrument.
- If not specified otherwise, the testing telescope is adjusted to infinity at 546 nm wavelength. Adjustment to other distances or wavelengths is also possible on demand.
- The nomenclature of the testing telescopes with 90°-viewing is as follows:

Example: F R 50/ 40/ 14,7

Testing telescope
90° viewing
Focal length
Tube diameter
Eyepiece focal length

Important:

Please specify reticle (see page 82) when ordering. Please specify direction of use if reticles with lettering (e.g. co-ordinate division etc.) are used so that the lettering will be right-side-up.

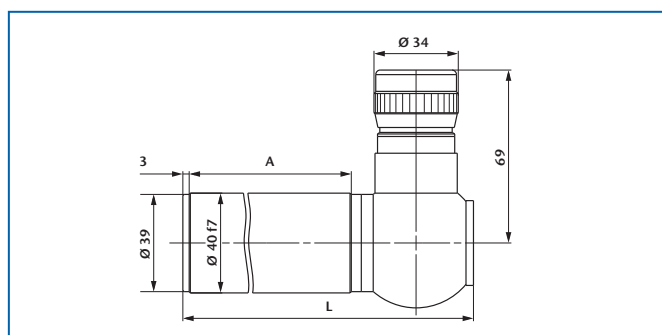

Ord.-No.	Description	Focal length	clear aperture	Field of view	A	L
227 041	FR 50/40/14,7	50	10	10,0°	65	116,5
227 042	FR 90/40/14,7	90	16	6,0°	65	116,5
227 043	FR 140/40/14,7	140	28	4,0°	118	169,5
227 044	FR 200/40/14,7	200	28	3,0°	173	224,5
227 045	FR 300/40/14,7	300	28	2,0°	274	325,5
227 046	FR 500/40/14,7	500	28	1,0°	474	525,5

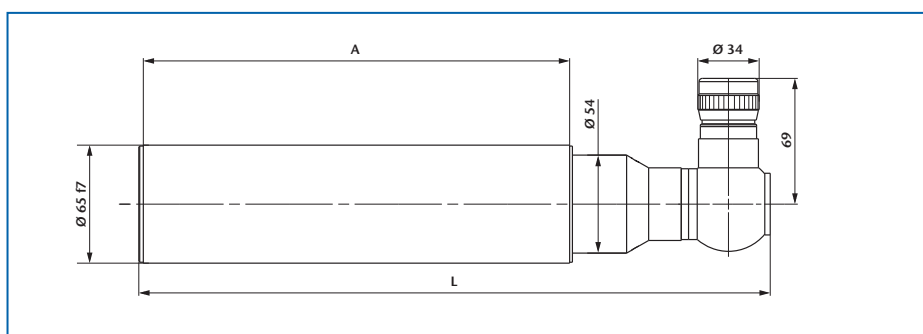
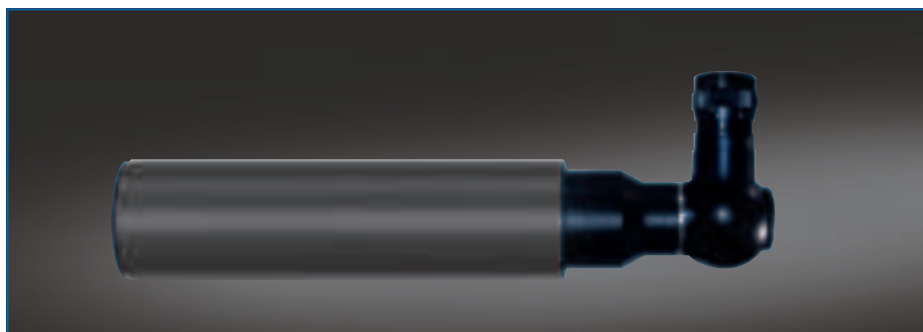

Ord.-No.	Description	Focal length	clear aperture	Field of view	A	L
227 047	FR 300/65/14,7	300	50	2,0°	233	346,0
227 048	FR 500/65/14,7	500	50	1,0°	415	528,0
227 049	FR 500T/65/14,7	500	50	1,0°	233	346,0

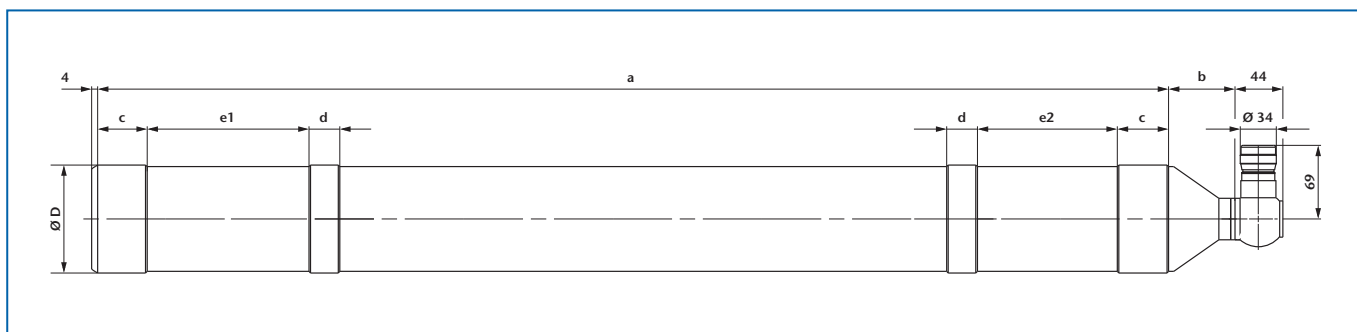
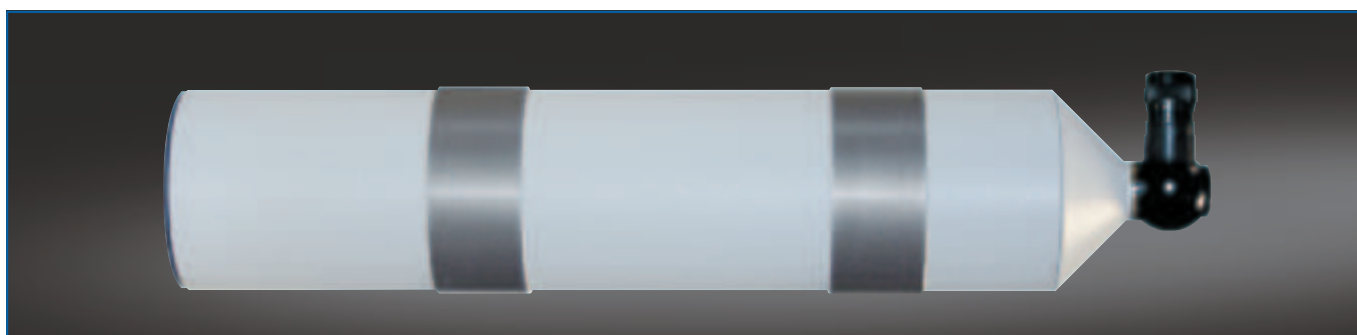

Ord.-No.	Description	Focal length	clear aperture	Field of view	D	a	b	c	d	e1	e2
227 052	FR 600/128/14,7	600	100	0,8°	Ø 128 f7	530	46	-	58	154	78
227 053	FR 1100/105/14,7	1100	78	0,5°	Ø 105 f7	1045	66	50	30	165	100

TESTING TELESCOPES

60°-VIEWING/60°-VIEWING WITH DOUBLE MICROMETER

Description:

For a general description of the operating principle of testing telescopes see page 20.

The basic function and design of testing telescopes with 60°-viewing is the same as of testing telescopes with 90°-viewing. The testing telescopes with 60° viewing contain a folding mirror (see following figure). The image appears upright but laterally reversed. This kind of testing telescopes is used for horizontally set-ups because the 60°-viewing is more ergonomic.

The testing telescopes with 60° viewing (figure A) are available also with mechanical micrometer (figure B) and digital double micrometers (figure C).

The scale division (SD) of the mechanical micrometer drum is 5 µm. For a general description of the operating principle of testing telescopes with double micrometers see page 28 and 30 respectively.

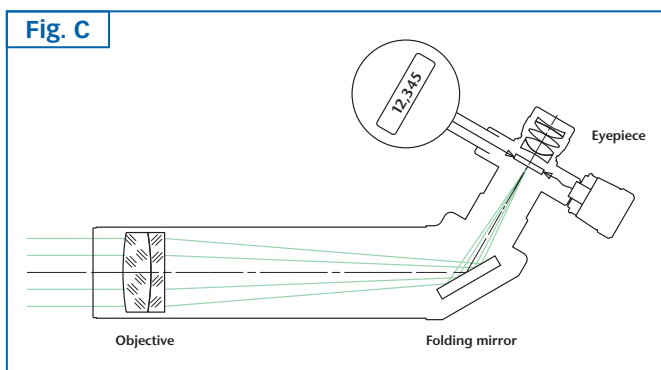
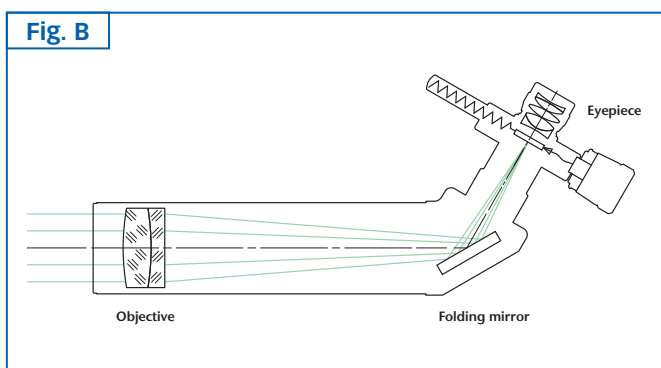
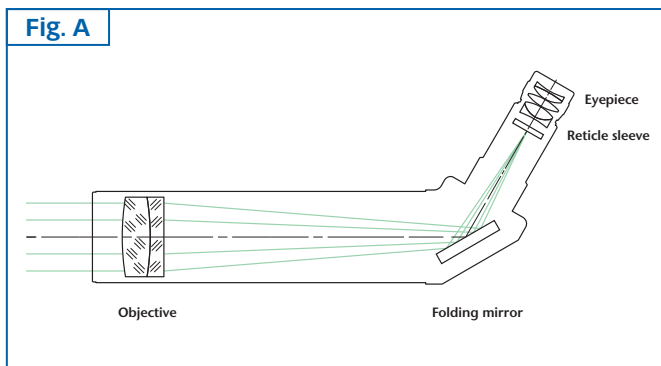

Notes on ordering:

- Testing telescope eyepiece is commonly $f=14,7$ mm but can be equipped with eyepieces $f=25$ mm or $f=10$ mm on request.
- One reticle and one eyepiece are included in the standard instrument.
- If not specified otherwise, the testing telescope is adjusted to infinity at 546 nm wavelength. Adjustment to other distances or wavelengths is also possible on demand.
- When ordering a telescope with digital double micrometer please specify the unit of display of the digital gauges (mm, arcsec, milliradians).
- The nomenclature of the testing telescopes with 60°-viewing and 60° viewing with double micrometer respectively is as follows:

Example:

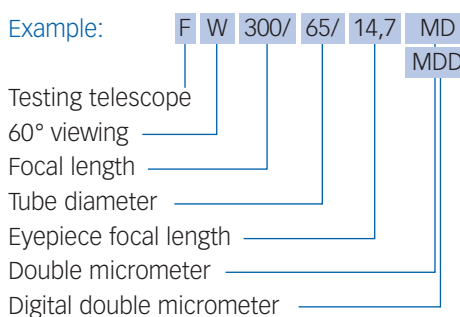

Important:

Please specify reticle (see page 82) when ordering.

60°-VIEWING

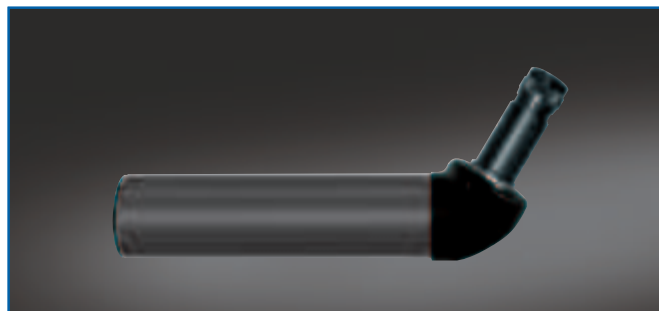
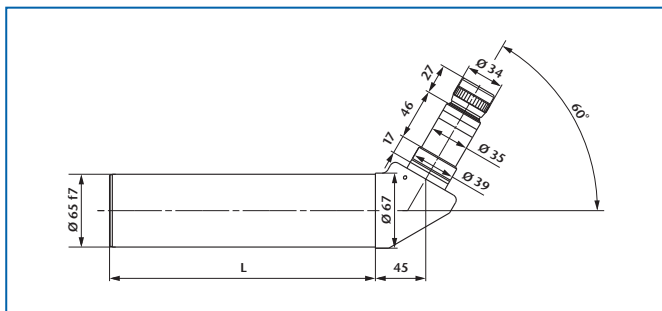

Ord.-No.	Description	Focal length	clear aperture	Field of view	L
227 067	FW 300/65/14,7	300	50	2,0°	233
227 068	FW 500/65/14,7	500	50	1,0°	415
227 069	FW 500T/65/14,7	500	50	1,0°	233

60°-VIEWING WITH DOUBLE MICROMETER

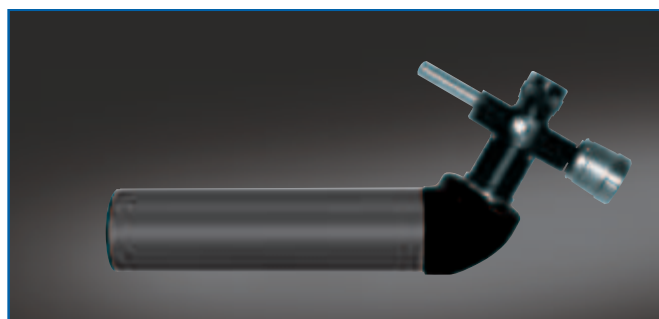
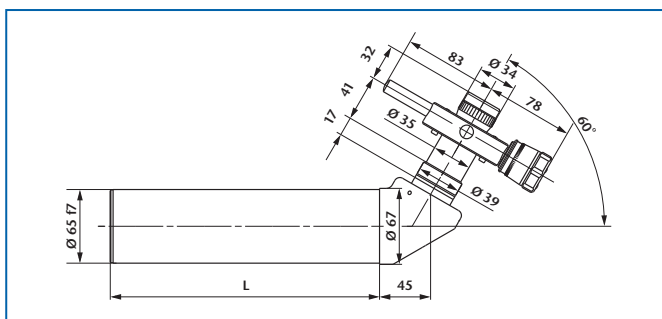

Ord.-No.	Description	Focal length	clear aperture	Meas. range	SD	L
227 177	FW 300/65/14,7 MD	300	50	0,6°	3,5"	233
227 178	FW 500/65/14,7 MD	500	50	0,4°	2,0"	415
227 179	FW 500T/65/14,7 MD	500	50	0,4°	2,0"	233

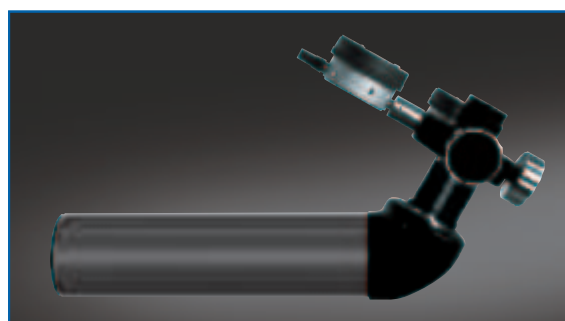
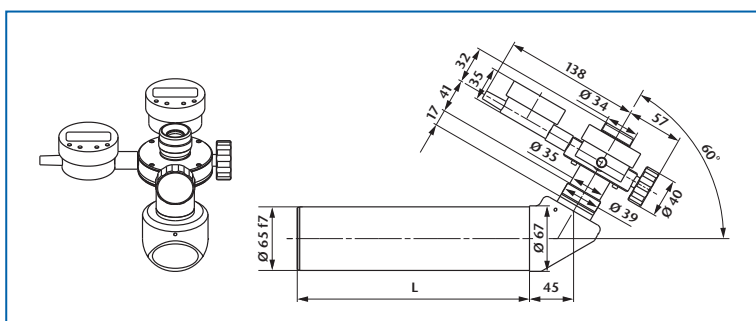

Ord.-No.	Description	Focal length	clear aperture	Meas. range	Resolution	L
227 217	FW 300/65/14,7 MDD	300	50	0,6°	1,0"	233
227 218	FW 500/65/14,7 MDD	500	50	0,4°	0,5"	415
227 219	FW 500T/65/14,7 MDD	500	50	0,4°	0,5"	233

TESTING TELESCOPES

STRAIGHT VIEWING – WITH DOUBLE MICROMETER

Description:

For a general description of the operating principle of testing telescopes see page 20.

Testing telescopes with mechanical double micrometer allow the measurement of deflection angles in two directions. The movement of the eyepiece reticle in x- and y-direction in the image plane can be read from the scale of the micrometer drums. The scale division (SD) is 5 μm .

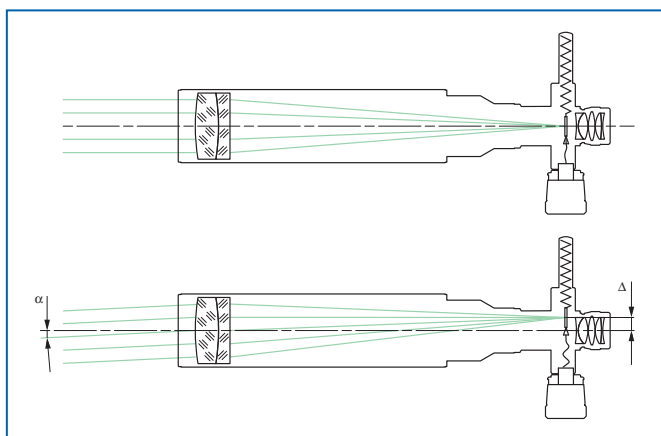

Application examples

(additional collimator required):

- Measurement of deflection angles
- Parallelism measurement of uncoated flats

Notes on ordering:

- Testing telescope eyepiece is commonly $f=14,7$ mm but can be equipped with eyepieces $f=25$ mm or $f=10$ mm on request.
- One reticle and one eyepiece are included in the standard instrument.
- If not specified otherwise, the testing telescope is adjusted to infinity at 546 nm wavelength. Adjustment to other distances or wavelengths is also possible on demand.
- The nomenclature of the testing telescopes with straight viewing and mechanical double micrometer is as follows:

Example: F G 50/ 40/ 14,7 MD

Testing telescope
Straight viewing
Focal length
Tube diameter
Eyepiece focal length
Double micrometer

Important:

Please specify reticle (see page 82) when ordering.

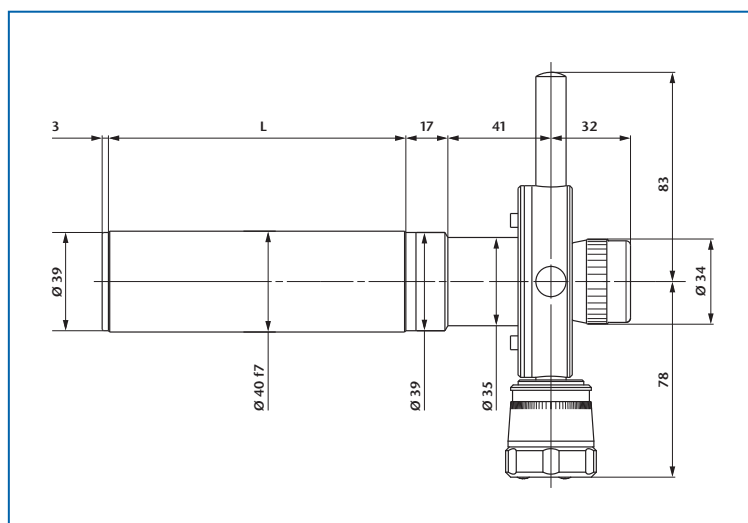

Ord.-No.	Description	Focal length	clear aperture	Meas. range	SD	L
227 161	FG 50/40/14,7 MD	50	10	3,2°	20,0"	65
227 162	FG 90/40/14,7 MD	90	16	2,0°	11,5"	65
227 163	FG 140/40/14,7 MD	140	28	1,2°	7,5"	118
227 164	FG 200/40/14,7 MD	200	28	0,8°	5,0"	173
227 165	FG 300/40/14,7 MD	300	28	0,6°	3,5"	274
227 166	FG 500/40/14,7 MD	500	28	0,4°	2,0"	474

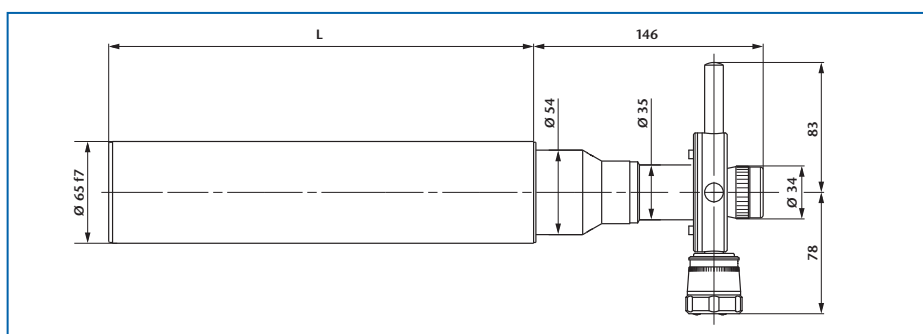
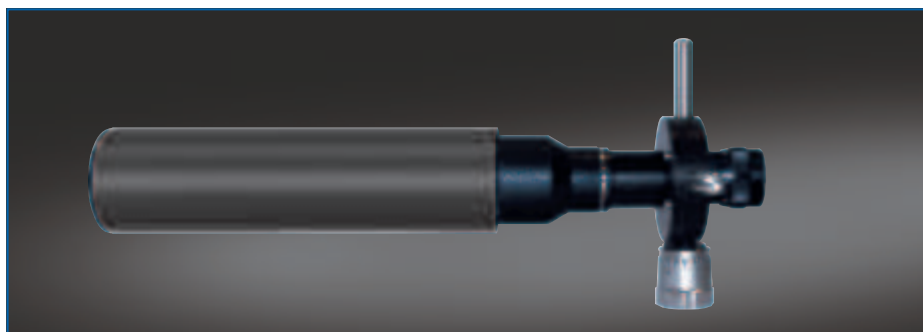

Ord.-No.	Description	Focal length	clear aperture	Meas. range	SD	L
227 167	FG 300/65/14,7 MD	300	50	0,6°	3,5"	233
227 168	FG 500/65/14,7 MD	500	50	0,4°	2,0"	415
227 169	FG 500T/65/14,7 MD	500	50	0,4°	2,0"	233

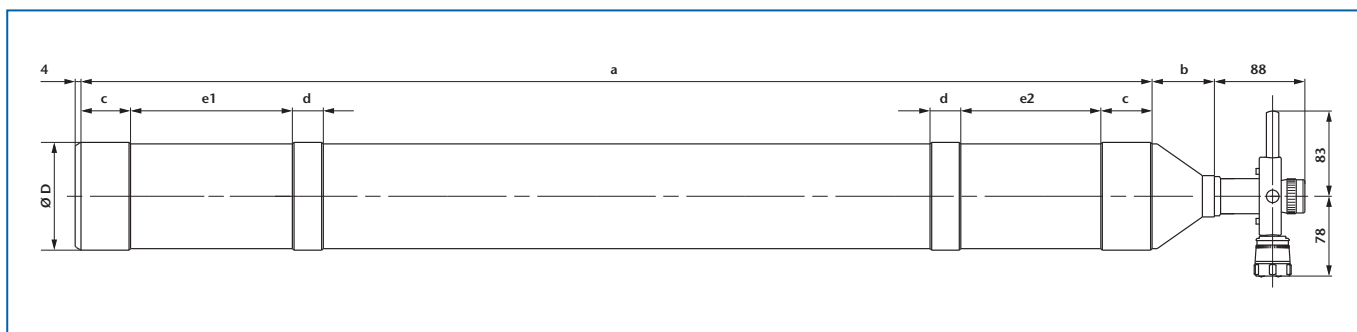
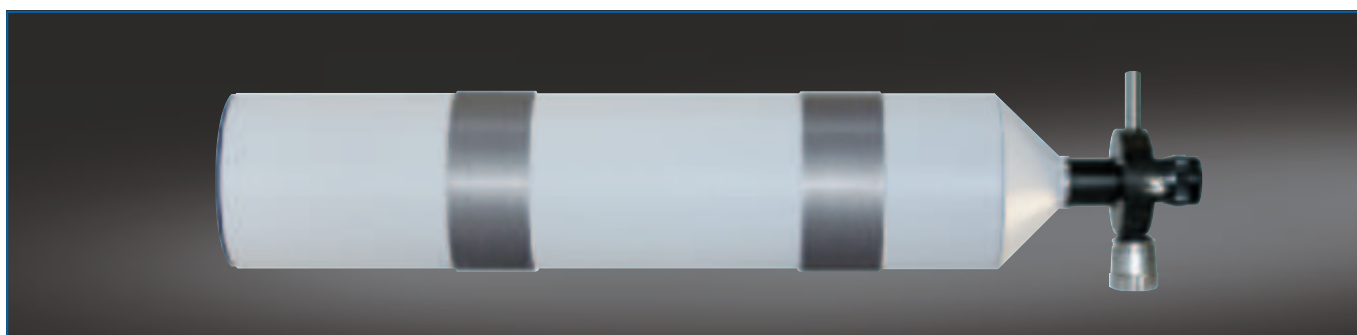

Ord.-No.	Description	Focal length	clear aperture	Meas. range	SD	D	a	b	c	d	e1	e2
227 172	FG 600/128/14,7 MD	600	100	0,30°	1,7"	Ø 128 f7	530	46	-	58	154	78
227 173	FG 1100/105/14,7 MD	1100	78	0,16°	1,0"	Ø 105 f7	1045	66	50	30	165	100

TESTING TELESCOPES

90°-VIEWING – WITH DOUBLE MICROMETER

Description:

For a general description of the operating principle of testing telescopes see page 20.

Testing telescopes with mechanical double micrometer allow the measurement of deflection angles in two directions. The movement of the eyepiece reticle in x- and y-direction in the image plane can be read from the scale of the micrometer drums. The scale division (SD) is 5 μm . The following figure shows the set-up of a testing telescope with 90° viewing. In contrast to a testing telescope with straight viewing the image appears upright and laterally reversed.

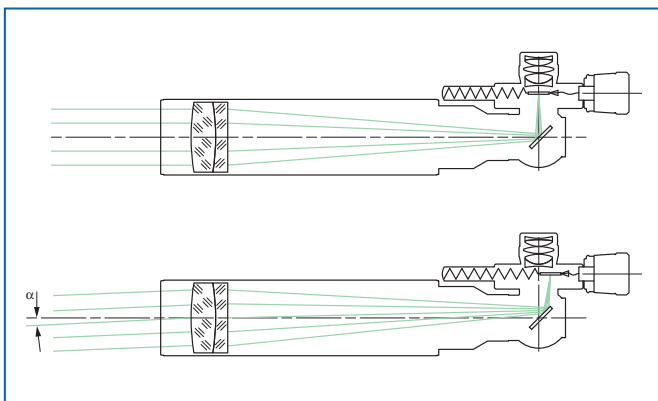

Application examples

(additional collimator required):

- Measurement of deflection angles
- Parallelism measurement of uncoated flats

Notes on ordering:

- Testing telescope eyepiece is commonly $f=14,7$ mm but can be equipped with eyepieces $f=25$ mm or $f=10$ mm on request.
- One reticle and one eyepiece are included in the standard instrument.
- If not specified otherwise, the testing telescope is adjusted to infinity at 546 nm wavelength. Adjustment to other distances or wavelengths is also possible on demand.
- The nomenclature of the testing telescopes with 90°-viewing and mechanical double micrometer is as follows:

Example: F R 50/ 40/ 14,7 MD

Testing telescope
90° viewing
Focal length
Tube diameter
Eyepiece focal length
Double micrometer

Important:

Please specify reticle (see page 82) when ordering. Please specify direction of use if reticles with lettering (e.g. co-ordinate division etc.) are used so that the lettering will be right-side-up.

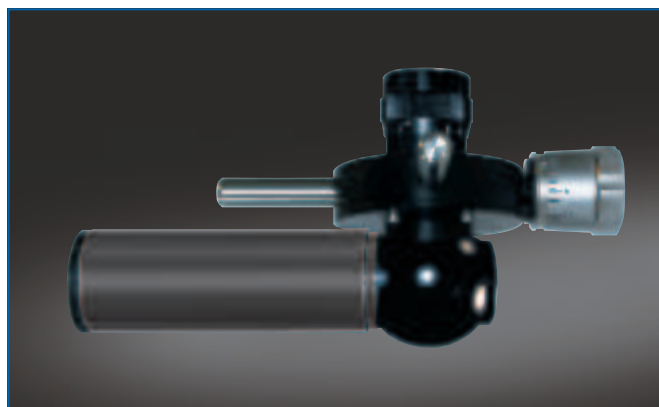
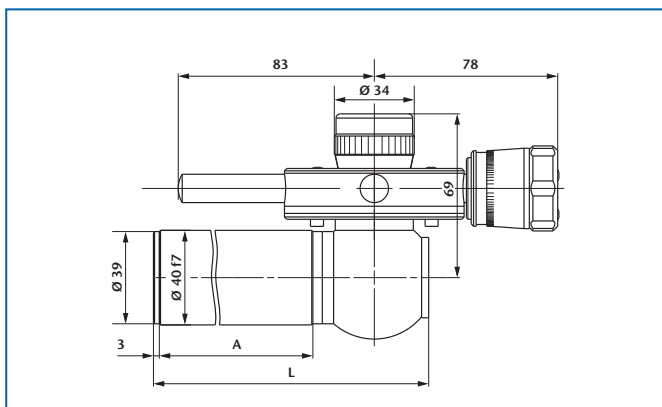

Ord.-No.	Description	Focal length	clear aperture	Meas. range	SD	A	L
227 181	FR 50/40/14,7 MD	50	10	3,2°	20,0"	65	116,5
227 182	FR 90/40/14,7 MD	90	16	2,0°	11,5"	65	116,5
227 183	FR 140/40/14,7 MD	140	28	1,2°	7,5"	118	169,5
227 184	FR 200/40/14,7 MD	200	28	0,8°	5,0"	173	224,5
227 185	FR 300/40/14,7 MD	300	28	0,6°	3,5"	274	325,5
227 186	FR 500/40/14,7 MD	500	28	0,4°	2,0"	474	525,5

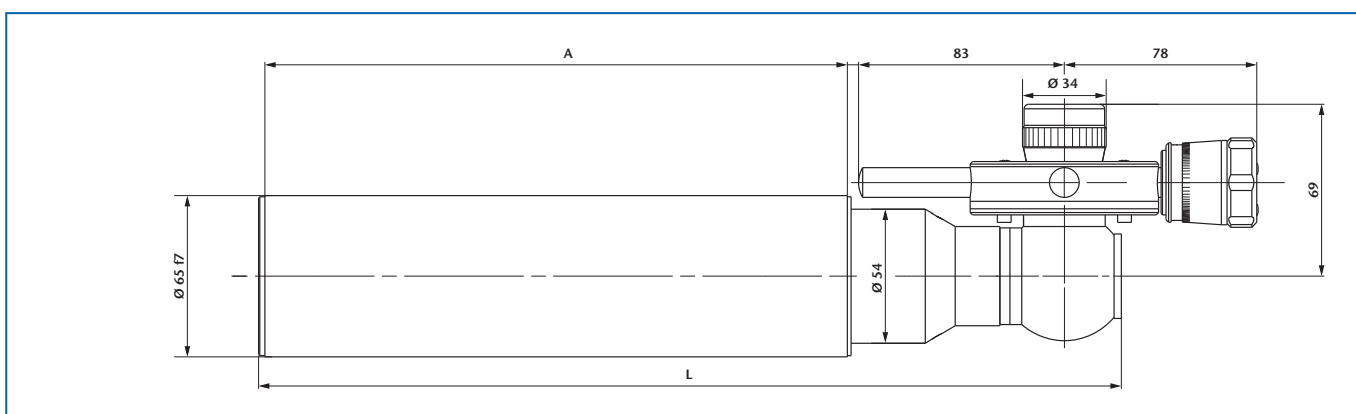
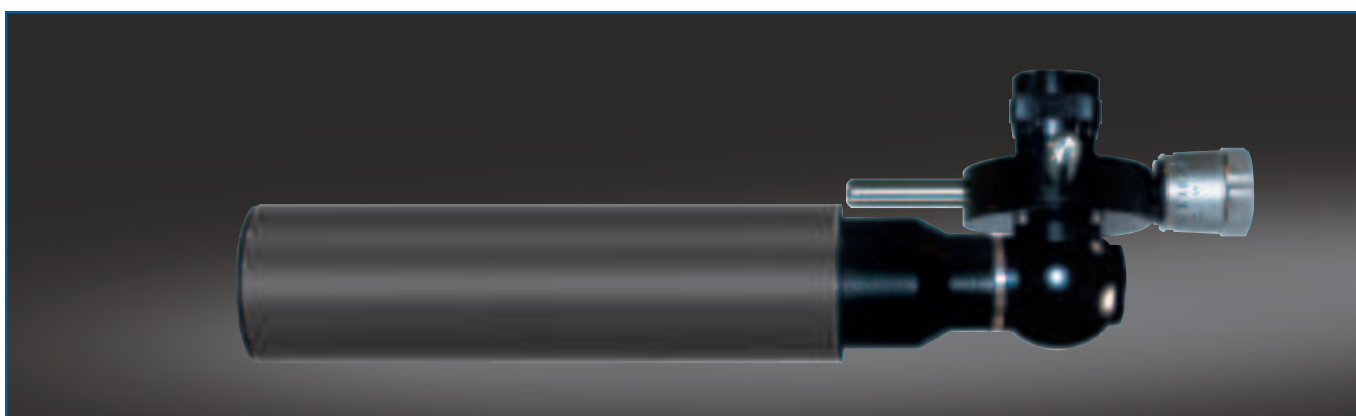

Ord.-No.	Description	Focal length	clear aperture	Meas. range	SD	A	L
227 187	FR 300/65/14,7 MD	300	50	0,6°	3,5"	233	346,0
227 188	FR 500/65/14,7 MD	500	50	0,4°	2,0"	415	528,0
227 189	FR 500T/65/14,7 MD	500	50	0,4°	2,0"	233	346,0

TESTING TELESCOPES

STRAIGHT VIEWING – WITH DIGITAL DOUBLE MICROMETER

Description:

For a general description of the operating principle of testing telescopes see page 20.

Testing telescopes with digital double micrometer allow the measurement of deflection angles in two directions. The programmable measuring gauges allow the operator to read the angular displacement in arcsec or mrad.

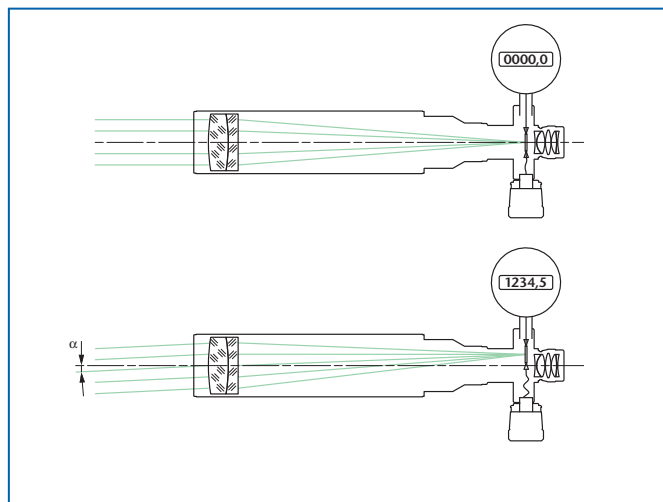

Application examples

(additional collimator required):

- Measurement of deflection angles
- Parallelism measurement of uncoated flats

Notes on ordering:

- Testing telescope eyepiece is commonly $f=14,7$ mm but can be equipped with eyepieces $f=25$ mm or $f=10$ mm on request.
- One reticle and one eyepiece are included in the standard instrument.
- If not specified otherwise, the testing telescope is adjusted to infinity at 546 nm wavelength. Adjustment to other distances or wavelengths is also possible on demand.
- Please specify the unit of reading (mm or arcsec or mrad) when ordering.
- The nomenclature of the testing telescopes with straight-viewing and digital double micrometer is as follows:

Example:

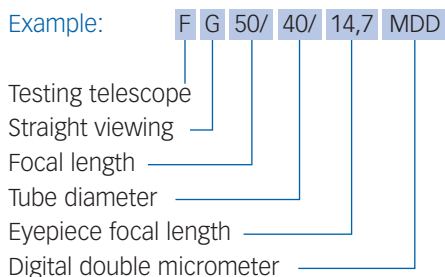

Important:

Please specify reticle (see page 82) when ordering.

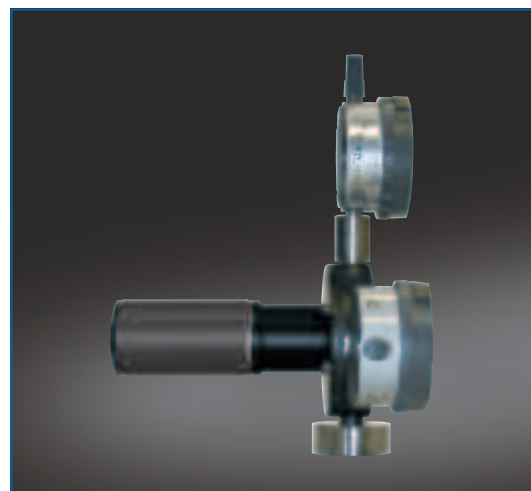
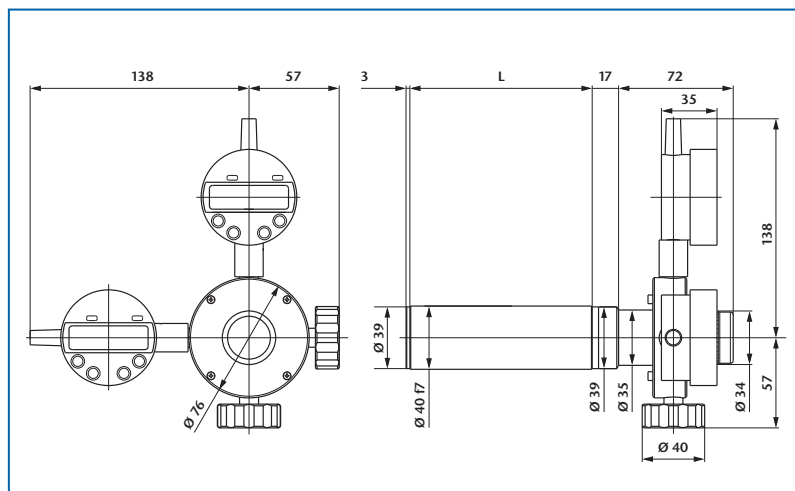

Ord.-No.	Description	Focal length	clear aperture	Meas. range	Resolution	L
227 201	FG 50/40/14,7 MDD	50	10	3,2°	5,0"	65
227 202	FG 90/40/14,7 MDD	90	16	2,0°	5,0"	65
227 203	FG 140/40/14,7 MDD	140	28	1,2°	2,0"	118
227 204	FG 200/40/14,7 MDD	200	28	0,8°	2,0"	173
227 205	FG 300/40/14,7 MDD	300	28	0,6°	1,0"	274
227 206	FG 500/40/14,7 MDD	500	28	0,4°	0,5"	474

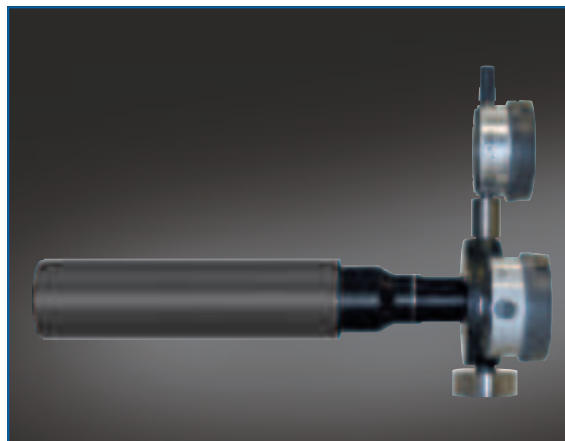
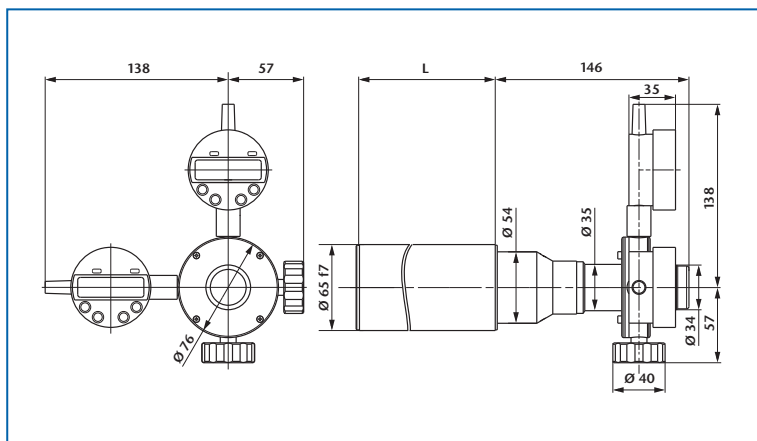

Ord.-No.	Description	Focal length	clear aperture	Meas. range	Resolution	L
227 207	FG 300/65/14,7 MDD	300	50	1,0°	1,0"	233
227 208	FG 500/65/14,7 MDD	500	50	0,5°	0,5"	415
227 209	FG 500T/65/14,7 MDD	500	50	0,5°	0,5"	233

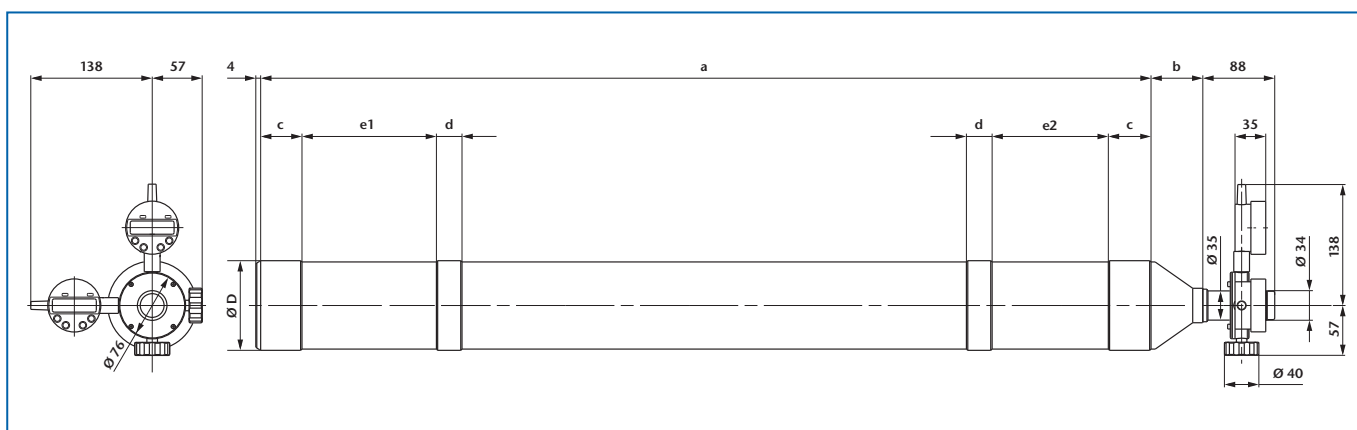
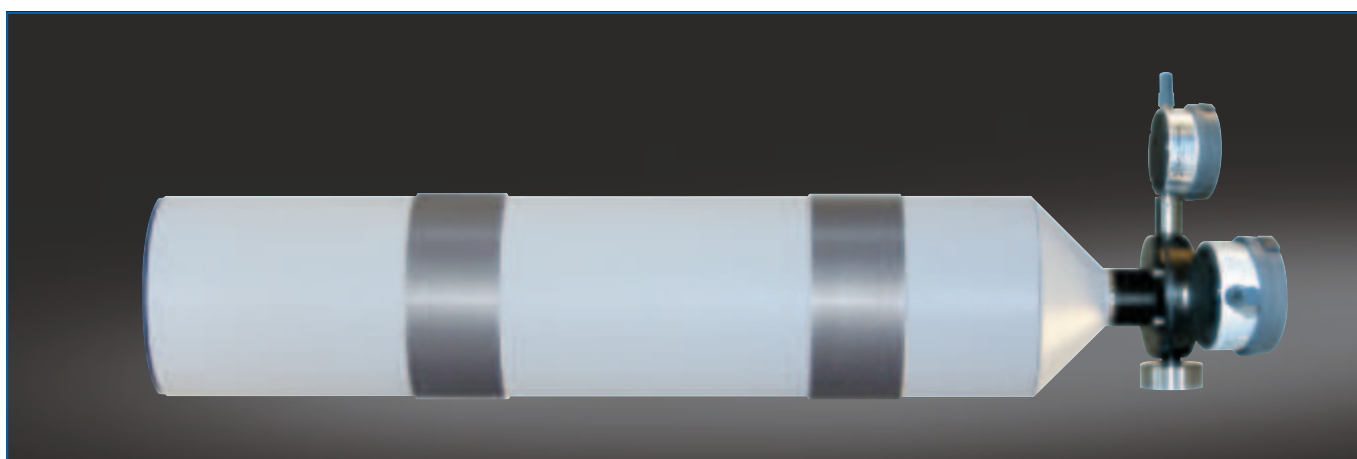

Ord.-No.	Description	Focal length	Free aperture	Meas. range	Resolution	D	a	b	c	d	e1	e2
227 212	FG 600/128/14,7 MDD	600	100	0,40°	0,5"	Ø 128 f7	530	46	-	58	154	78
227 213	FG 1100/105/14,7 MDD	1100	78	0,24°	0,2"	Ø 105 f7	1045	66	50	30	165	100

TESTING TELESCOPES

FOCUS ADJUSTABLE – WITH STRAIGHT VIEWING

Description:

For a general description of the operating principle of testing telescopes see page 20.

An adjustable focus telescope allows the distance between reticle and telescope objective to be adjusted for measurements made at other than infinity. Additionally, infinity can be set for different wavelengths of light.

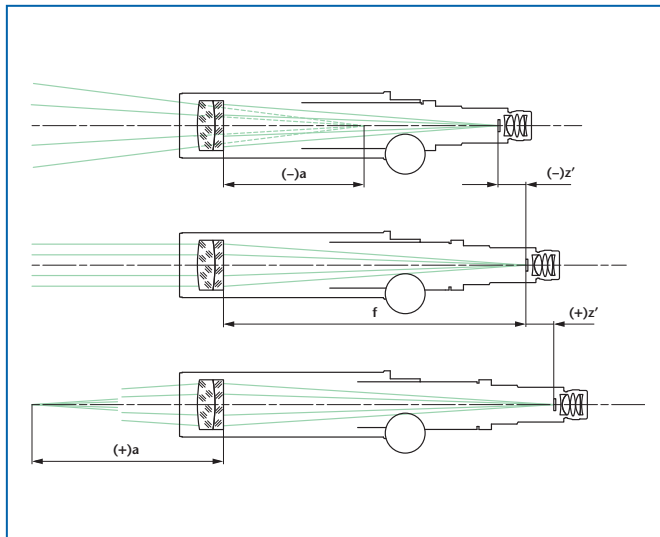

Notes on ordering:

- Testing telescope eyepiece is commonly $f=14,7$ mm but can be equipped with eyepieces $f=25$ mm or $f=10$ mm on request.
- One reticle and one eyepiece are included in the standard instrument.
- The nomenclature of the focus adjustable telescope with straight viewing is as follows:

Example: F G V 90/ 40/ 14,7 ±6

Testing telescope
Straight viewing
Variable
Focal length
Tube diameter
Eyepiece focal length
Tube extension in mm

Important:

Please specify reticle (see page 82) when ordering.

Application examples:

- Adjustment of optical and mechanical systems
- Qualitative testing of image quality of optical elements and systems (additional collimator required)
- Testing at different wavelengths of light

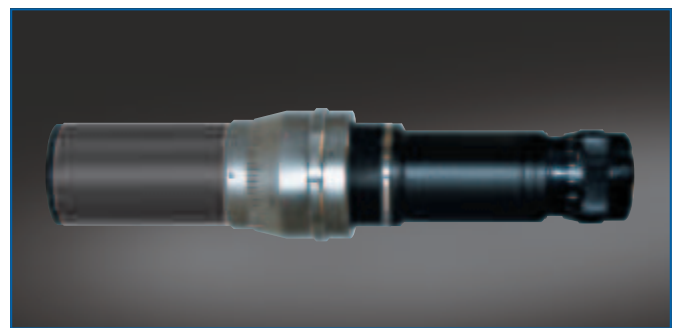
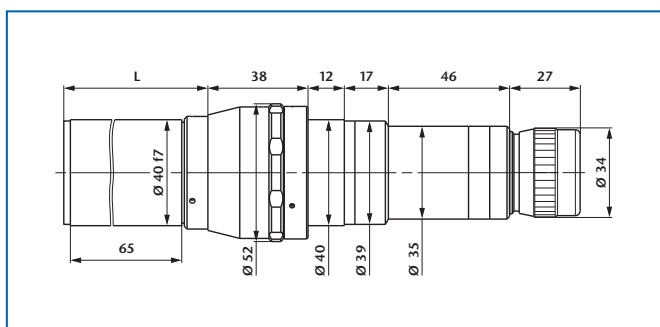

Ord.-No.	Description	Focal length	Free aperture	Tube extension	Field of view	Distance range	L
227 501	FGV 90/40/14,7/±6	90	16	±6	6,0°	- ...-1,25 m 1,40 m...+	77±6
227 502	FGV 90/40/14,7/+12	90	16	+12	6,0°	0,80 m...+	71 ⁺¹²
227 503	FGV 90/40/14,7/-12	90	16	-12	6,0°	- ...-0,60 m	83 ⁻¹²
227 504	FGV 140/40/14,7/±6	140	28	±6	4,0°	- ...-3,10 m 3,30 m...+	77±6
227 505	FGV 140/40/14,7/+12	140	28	+12	4,0°	1,70 m...+	71 ⁺¹²
227 506	FGV 140/40/14,7/-12	140	28	-12	4,0°	- ...-1,40 m	83 ⁻¹²

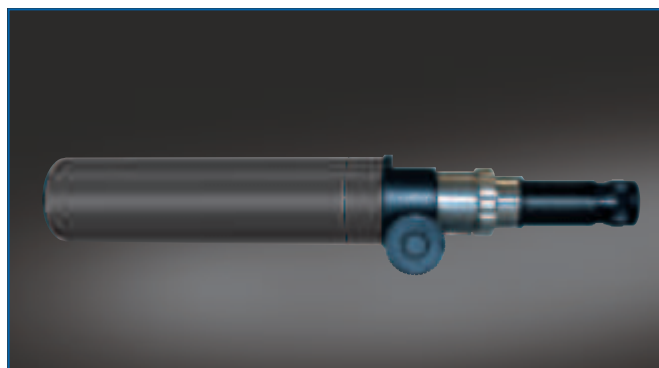
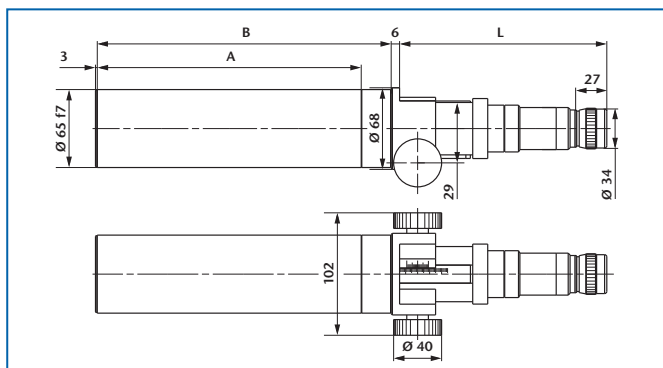

Ord.-No.	Description	Focal length	clear aperture	Tube extension	Field of view	Distance range	A	B	L
227 507	FGV 300/65/14,7/±25	300	50	±25	2,0°	- ...-3,4 m 3,8 m...+	220	245	173±25
227 508	FGV 300/65/14,7/+50	300	50	+50	2,0°	2,1 m...+	220	270	148 ⁺⁵⁰
227 509	FGV 300/65/14,7/-50	300	50	-50	2,0°	- ...-1,5 m	220	220	198 ⁻⁵⁰
227 510	FGV 500/65/14,7/±50	500	50	±50	1,0°	- ...-4,5 m 5,4 m...+	310	360	198±50
227 511	FGV 500/65/14,7/+100	500	50	+100	1,0°	3,0 m...+	310	410	148 ⁺¹⁰⁰
227 512	FGV 500/65/14,7/-100	500	50	-100	1,0°	- ...-1,5 m	310	310	248 ⁻¹⁰⁰

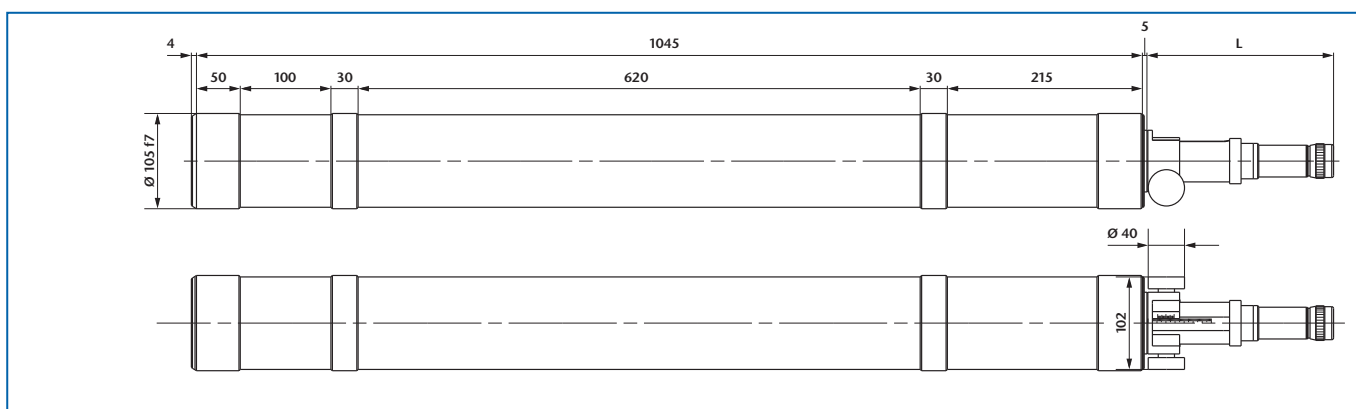
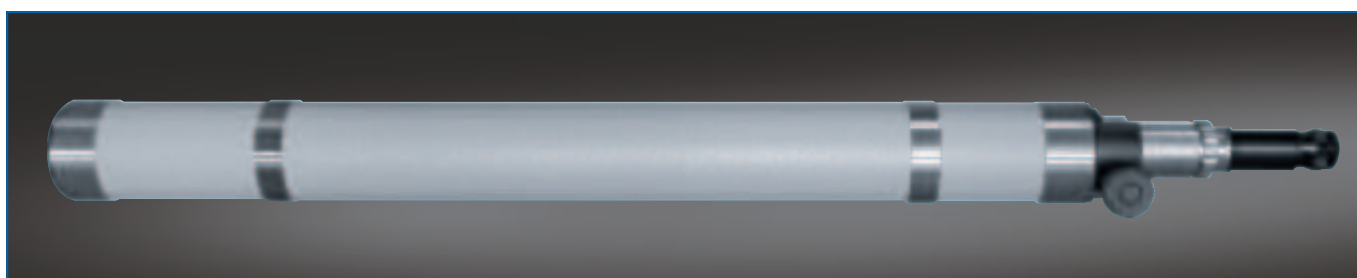

Ord.-No.	Description	Focal length	Free aperture	Tube extension	Field of view	Distance range	L
227 516	FGV 1100/105/14,7/±50	1100	78	±50	0,5°	- ...-23,70 m 25,80 m...+	202±50
227 517	FGV 1100/105/14,7/+100	1100	78	+100	0,5°	13,20 m...+	202 ⁺¹⁰⁰
227 518	FGV 1100/105/14,7/-100	1100	78	-100	0,5°	- ...-12,00 m	202 ⁻¹⁰⁰

TESTING TELESCOPES

FOCUS ADJUSTABLE – WITH 90°-VIEWING

Description:

For a general description of the operating principle of testing telescopes see page 20.

An adjustable focus telescope allows the distance between reticle and telescope objective to be adjusted for measurements made at other than infinity. Additionally, infinity can be set for different wavelengths of light.

The following figure shows the set-up of a focusable telescope with 90° viewing. In contrast to a telescope with straight viewing the image appears upright and laterally reversed.

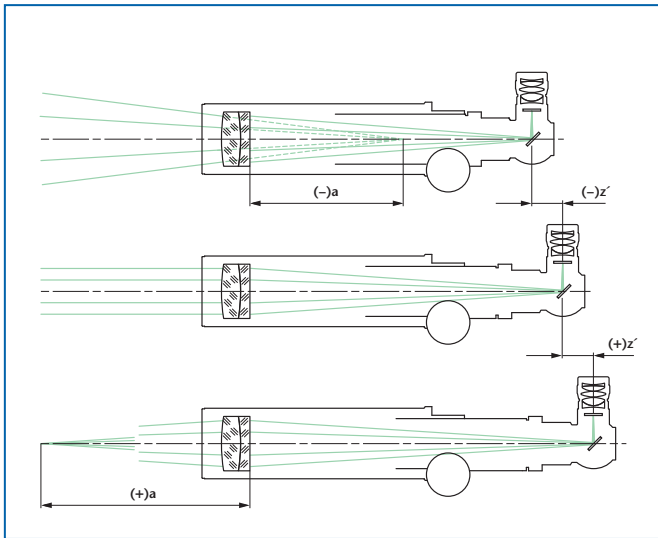

Application examples:

- Adjustment of optical and mechanical systems
- Qualitative testing of image quality of optical elements and systems (additional collimator required)
- Testing at different wavelengths of light

Notes on ordering:

- Telescope eyepiece is commonly $f=14,7$ mm but can be equipped with eyepieces $f=25$ mm or $f=10$ mm on request.
- One reticle and one eyepiece are included in the instrument.
- The nomenclature of the focus adjustable testing telescopes with 90°-viewing is as follows:

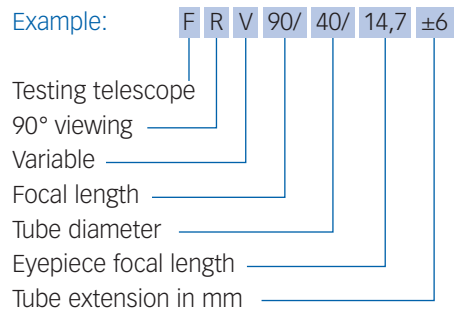

Important:

Please specify reticle (see page 82) when ordering.
Please specify direction of use if reticles with lettering are used so that the lettering will be right-side-up.

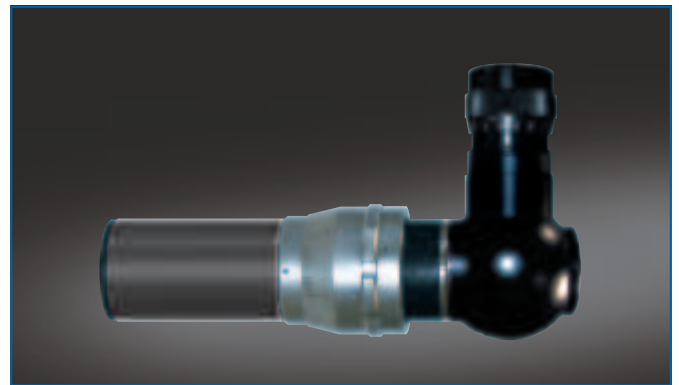

Ord.-No.	Description	Focal length	Free aperture	Tube extension	Field of view	Distance range	A	L
227 541	FRV 90/40/14,7/±6	90	16	±6	6,0°	- ...-1,25 m 1,40 m...+	60±6	176,5±6
227 542	FRV 90/40/14,7/+12	90	16	+12	6,0°	0,80 m...+	54 ⁺¹²	170,5 ⁺¹²
227 543	FRV 90/40/14,7/-12	90	16	-12	6,0°	- ...-0,60 m	66 ⁻¹²	182,5 ⁻¹²
227 544	FRV 140/40/14,7/±6	140	28	±6	4,0°	- ...-3,10 m 3,30 m...+	60±6	176,5±6
227 545	FRV 140/40/14,7/+12	140	28	+12	4,0°	1,70 m...+	54 ⁺¹²	170,5 ⁺¹²
227 546	FRV 140/40/14,7/-12	140	28	-12	4,0°	- ...-1,40 m	66 ⁻¹²	182,5 ⁻¹²

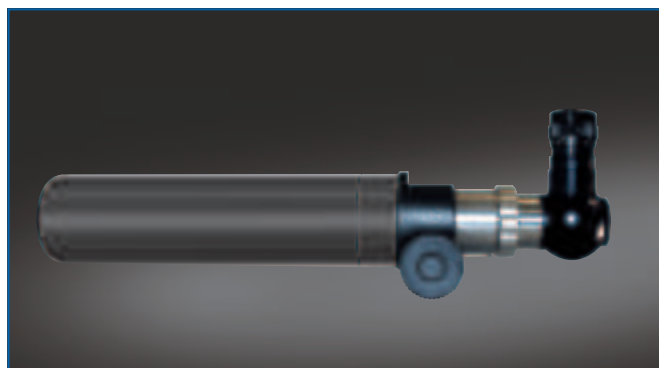
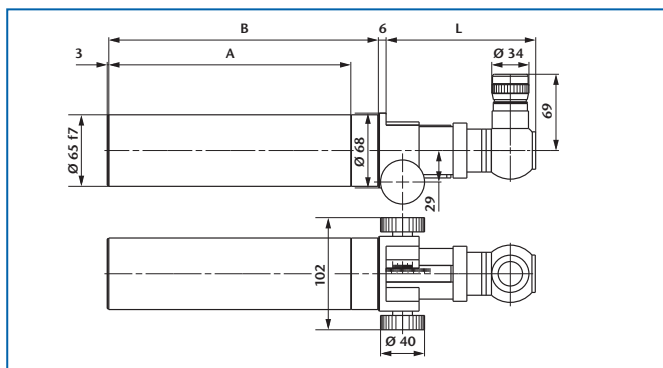

Ord.-No.	Description	Focal length	clear aperture	Tube extension	Field of view	Distance range	A	B	L
227 547	FRV 300/65/14,7/±25	300	50	±25	2,0°	- ...-3,4 m 3,8 m...+	220	245	140±25
227 548	FRV 300/65/14,7/+50	300	50	+50	2,0°	2,1 m...+	220	270	115 ⁺⁵⁰
227 549	FRV 300/65/14,7/-50	300	50	-50	2,0°	- ...-1,5 m	220	220	165 ⁻⁵⁰
227 550	FRV 500/65/14,7/±50	500	50	±50	1,0°	- ...-4,5 m 5,4 m...+	310	360	165±50
227 551	FRV 500/65/14,7/+100	500	50	+100	1,0°	3,0 m...+	310	410	115 ⁺¹⁰⁰
227 552	FRV 500/65/14,7/-100	500	50	-100	1,0°	- ...-1,5 m	310	310	215 ⁻¹⁰⁰

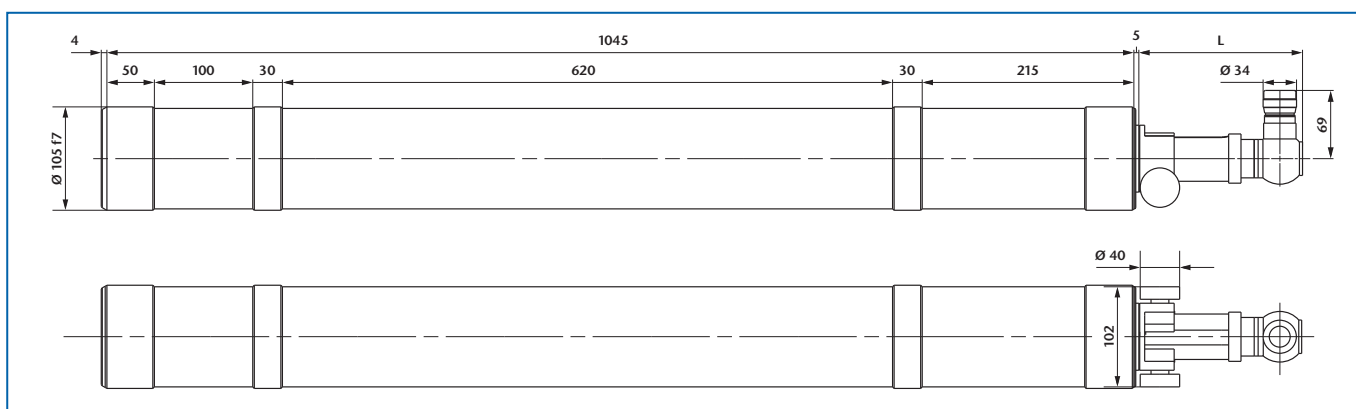
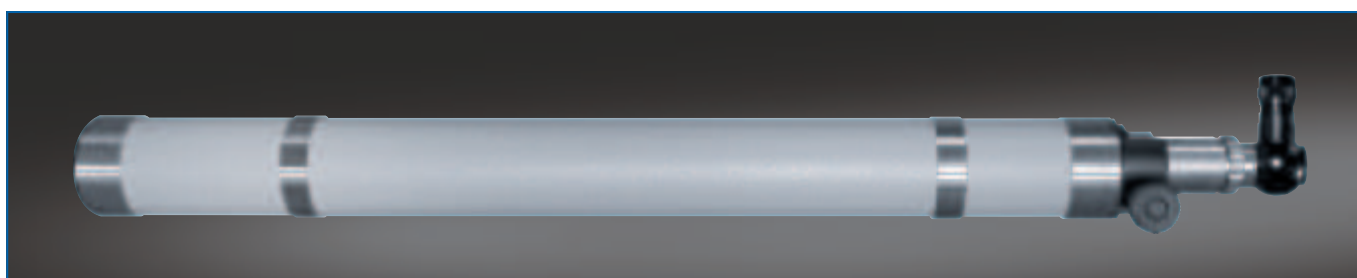

Ord.-No.	Description	Focal length	Free aperture	Tube extension	Field of view	Distance range	L
227 556	FRV 1100/105/14,7/±50	1100	78	±50	0,5°	- ...-23,70m 25,80 m...+	161±50
227 557	FRV 1100/105/14,7/+100	1100	78	+100	0,5°	13,20 m...+	161 ⁺¹⁰⁰
227 558	FRV 1100/105/14,7/-100	1100	78	-100	0,5°	- ...-12,00 m	161 ⁻¹⁰⁰

TESTING TELESCOPES

FOCUS ADJUSTABLE – STRAIGHT VIEWING WITH DOUBLE MICROMETER

Description:

For a general description of the operating principle of testing telescopes see page 20.

An adjustable focus telescope with mechanical double micrometer allows the distance between reticle and telescope objective to be adjusted for measurements made at other than infinity. Additionally, infinity can be set for different wavelengths of light. The scale division (SD) of the micrometer drums is 5 μ m.

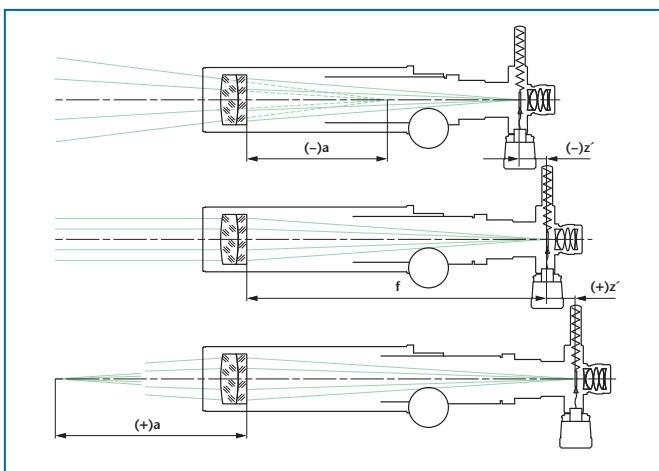

Application examples:

- Adjustment of optical and mechanical systems
- Qualitative testing of image quality of optical elements and systems (additional collimator required)
- Testing at different wavelengths of light
- Measurement of deflection angles (add. collimator required)

Notes on ordering:

- Telescope eyepiece is commonly $f=14,7$ mm but can be equipped with eyepieces $f=25$ mm or $f=10$ mm on request.
- One reticle and one eyepiece are included in the instrument.
- The nomenclature of the focus adjustable testing telescopes with straight viewing and mechanical double micrometer is as follows:

Example: F G V 90/ 40/ 14,7 \pm 6 MD

Testing telescope
 Straight viewing
 Variable
 Focal length
 Tube diameter
 Eyepiece focal length
 Tube extension in mm
 Double micrometer

Important:

Please specify reticle (see page 82) when ordering.

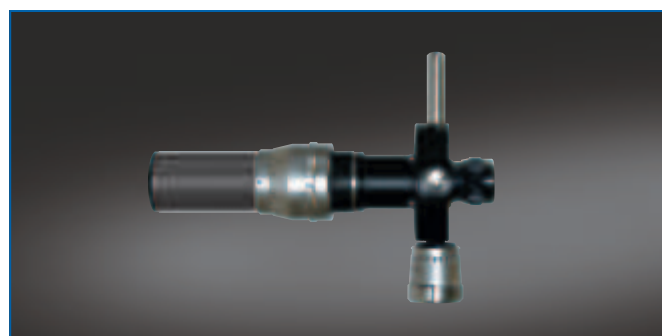
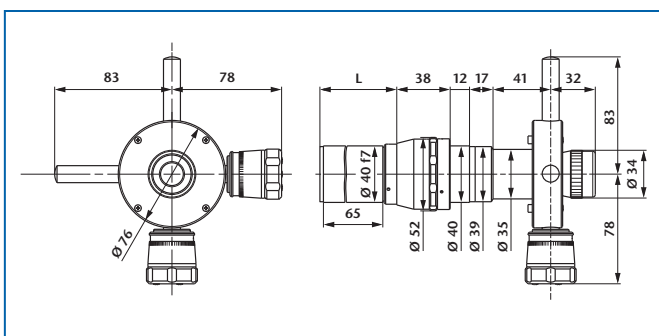

Ord.-No.	Description	Focal length	Free aperture	Tube extension	Meas. range	SD	Distance range	L
227 661	FGV 90/40/14,7/ \pm 6 MD	90	16	\pm 6	2,0°	11,5"	- ...-1,25 m 1,40 m...+	77 \pm 6
227 662	FGV 90/40/14,7/+12 MD	90	16	+12	2,0°	11,5"	0,80 m...+	71 ⁺¹²
227 663	FGV 90/40/14,7/-12 MD	90	16	-12	2,0°	11,5"	- ...-0,60 m	83 ⁻¹²
227 664	FGV 140/40/14,7/ \pm 6 MD	140	28	\pm 6	1,2°	7,5"	- ...-3,10 m 3,30 m...+	77 \pm 6
227 665	FGV 140/40/14,7/+12 MD	140	28	+12	1,2°	7,5"	1,70 m...+	71 ⁺¹²
227 666	FGV 140/40/14,7/-12 MD	140	28	-12	1,2°	7,5"	- ...-1,40 m	83 ⁻¹²

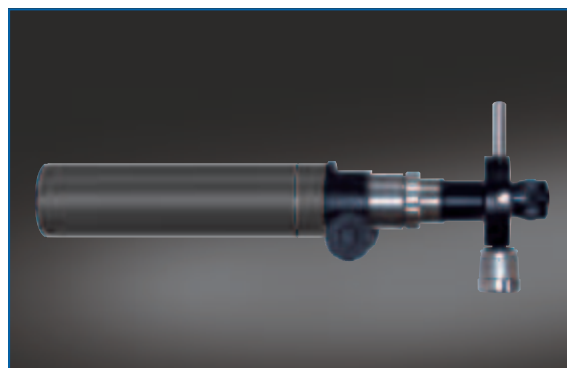
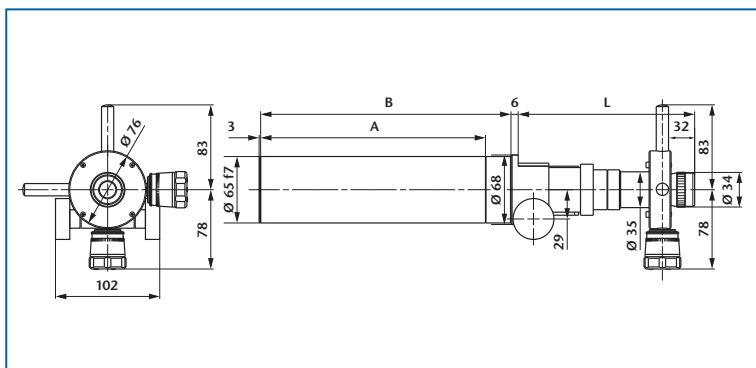

Ord.-No.	Description	Focal length	Free aperture	Tube extension	Meas. range	SD	Distance range	A	B	L
227 667	FGV 300/65/14,7/±25 MD	300	50	±25	0,6°	3,5"	- ...-3,4 m 3,8 m...+	220	245	173±25
227 668	FGV 300/65/14,7/+50 MD	300	50	+50	0,6°	3,5"	2,1 m...+	220	270	148 ⁺⁵⁰
227 669	FGV 300/65/14,7/-50 MD	300	50	-50	0,6°	3,5"	- ...-1,5 m	220	220	198 ⁻⁵⁰
227 670	FGV 500/65/14,7/±50 MD	500	50	±50	0,4°	2,0"	- ...-4,5 m 5,4 m...+	310	360	198±50
227 671	FGV 500/65/14,7/+100 MD	500	50	+100	0,4°	2,0"	3,0 m...+	310	410	148 ⁺¹⁰⁰
227 672	FGV 500/65/14,7/-100 MD	500	50	-100	0,4°	2,0"	- ...-1,5 m	310	310	248 ⁻¹⁰⁰

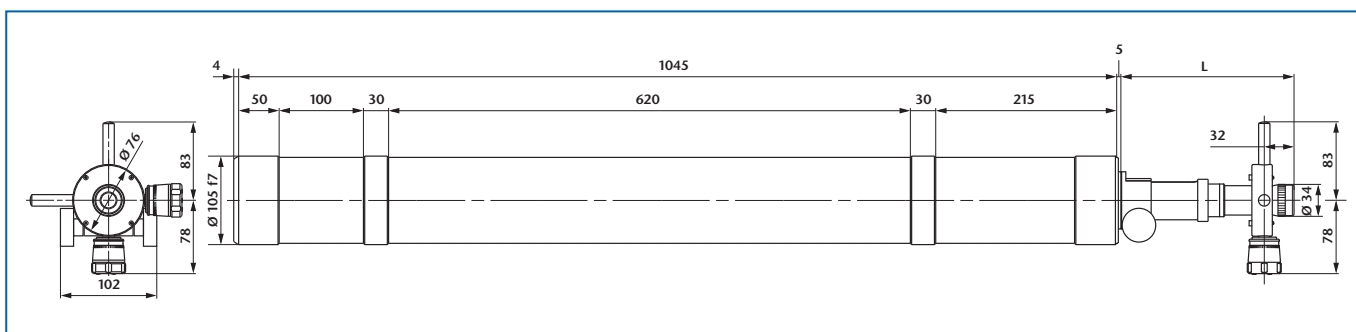
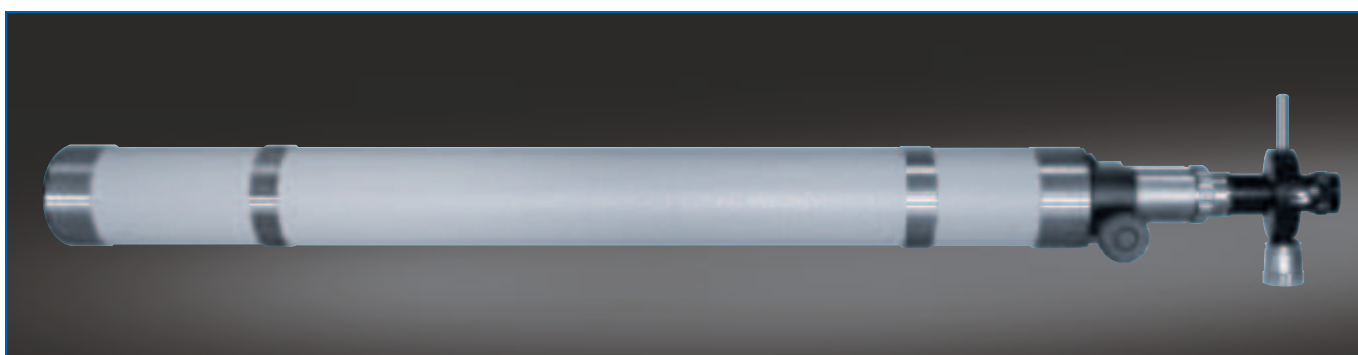

Ord.-No.	Description	Focal length	Free aperture	Tube extension	Meas. range	SD	Distance range	L
227 676	FGV 1100/105/±50 MD	1100	78	±50	0,16°	1,0"	- ...-23,70 m 25,80 m...+	202±50
227 677	FGV 1100/105/+100 MD	1100	78	+100	0,16°	1,0"	13,20 m...+	202 ⁺¹⁰⁰
227 678	FGV 1100/105/-100 MD	1100	78	-100	0,16°	1,0"	- ...-12,00 m	202 ⁻¹⁰⁰

TESTING TELESCOPES

FOCUS ADJUSTABLE – STRAIGHT VIEWING WITH DIGITAL DOUBLE MICROMETER

Description:

For a general description of the operating principle of testing telescopes see page 20.

An adjustable focus telescope with digital double micrometer allows the distance between reticle and telescope objective to be adjusted for measurements made at other than infinity. Additionally, infinity can be set for different wavelengths of light. The programmable digital gauges of the telescope allow the operator to read directly angular displacement in arcsec or mrad.

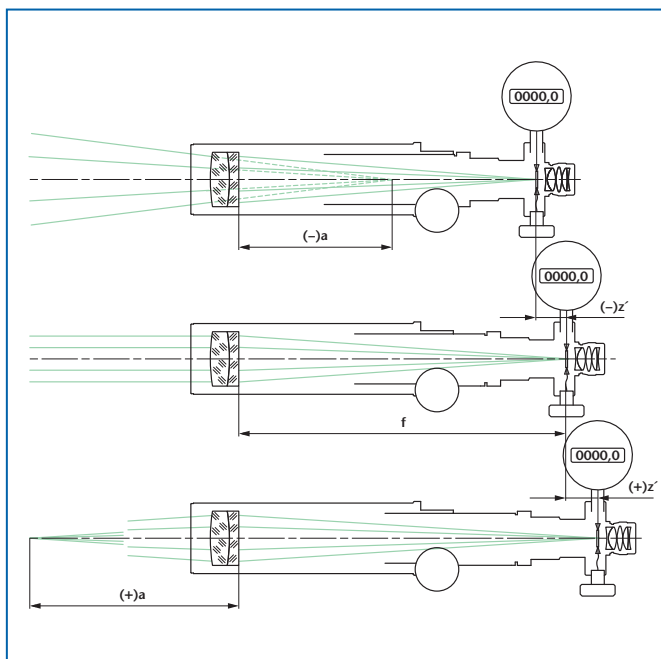

Application examples:

- Adjustment of optical and mechanical systems
- Measurement of big radii of curvature (additional collimator required)
- Adjustment for different wavelengths of light
- Measurement of deflection angles (additional collimator required)

Notes on ordering:

- Testing telescopes can be equipped with eyepieces $f=25$ mm or $f=10$ mm on request.
- One reticle and eyepiece are included in the instrument.
- Please specify the unit of reading (mm or arcsec or mrad) when ordering.
- The nomenclature of the adjustable testing telescopes with straight viewing and digital double micrometer is as follows:

Example:

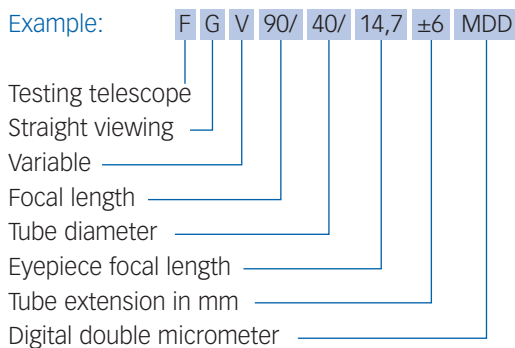

Important:

Please specify reticle (see page 82) when ordering.

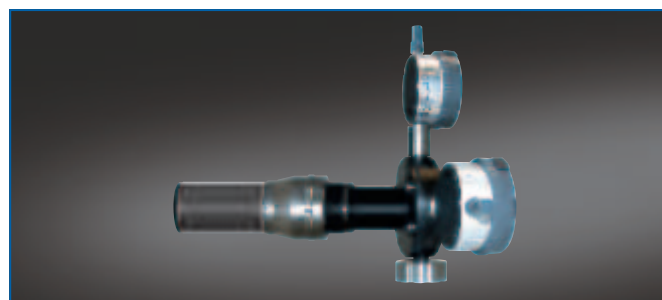
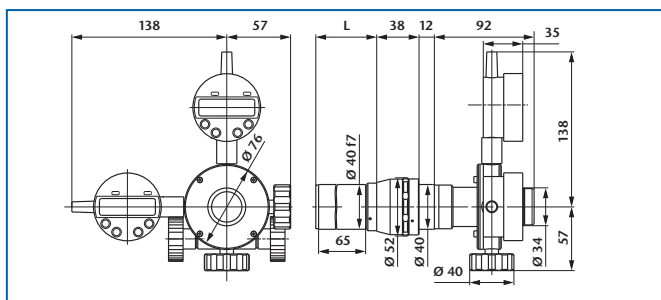

Ord.-No.	Description	Focal length	clear aperture	Tube extension	Meas. range	Resolution	Distance range	L
227 681	FGV 90/40/14,7/±6 MDD	90	16	±6	6,0°	5,0"	- ...-1,25 m 1,40 m...+	77±6
227 682	FGV 90/40/14,7/+12 MDD	90	16	+12	6,0°	5,0"	0,80 m...+	71 ⁺¹²
227 683	FGV 90/40/14,7/-12 MDD	90	16	-12	6,0°	5,0"	- ...-0,60 m	83 ₋₁₂
227 684	FGV 140/40/14,7/±6 MDD	140	28	±6	4,0°	2,0"	- ...-3,10 m 3,30 m...+	77±6
227 685	FGV 140/40/14,7/+12 MDD	140	28	-12	4,0°	2,0"	1,70 m...+	71 ₋₁₂
227 686	FGV 140/40/14,7/-12 MDD	140	28	-12	4,0°	2,0"	- ...-1,40 m	83 ₋₁₂

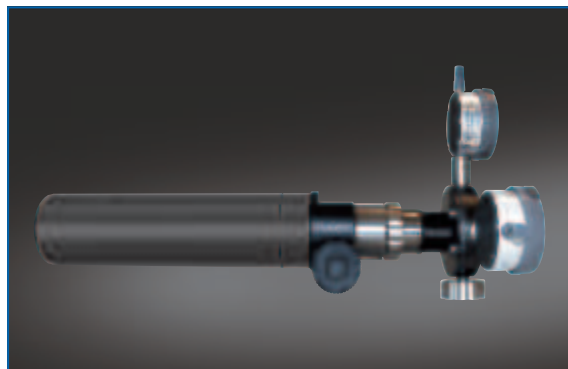
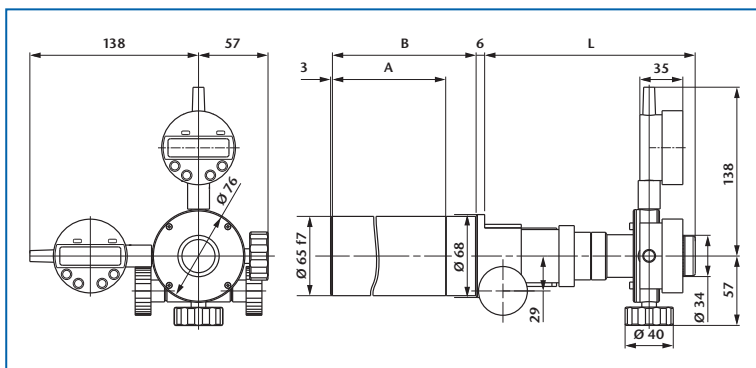

Ord.-No.	Description	Focal length	clear aperture	Tube extension	Meas. range	Resolution	Distance range	A	B	L
227 687	FGV 300/65/14,7/±25 MDD	300	50	±25	1,0°	0,5"	- ...-3,4 m 3,8 m...+	220	245	140±25
227 688	FGV 300/65/14,7/+50 MDD	300	50	+50	1,0°	0,5"	2,1 m...+	220	270	115 ⁺⁵⁰
227 689	FGV 300/65/14,7/-50 MDD	300	50	-50	1,0°	0,5"	- ...-1,5 m	220	220	165 ⁻⁵⁰
227 690	FGV 500/65/14,7/±50 MDD	500	50	±50	0,5°	0,2"	- ...-4,5 m 5,4 m...+	310	360	165±50
227 691	FGV 500/65/14,7/+100 MDD	500	50	+100	0,5°	0,2"	3,0 m...+	310	410	115 ⁺¹⁰⁰
227 692	FGV 500/65/14,7/-100 MDD	500	50	-100	0,5°	0,2"	- ...-1,5 m	310	310	215 ⁻¹⁰⁰

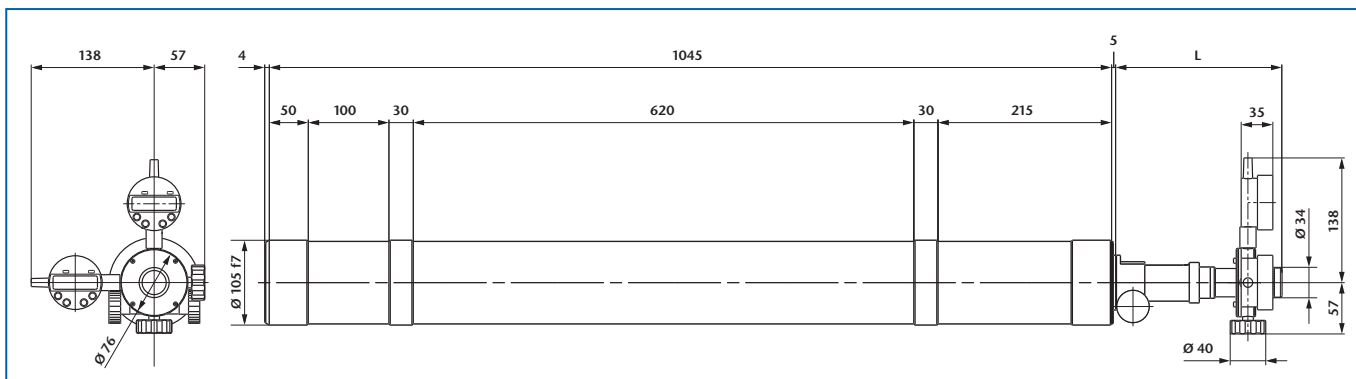
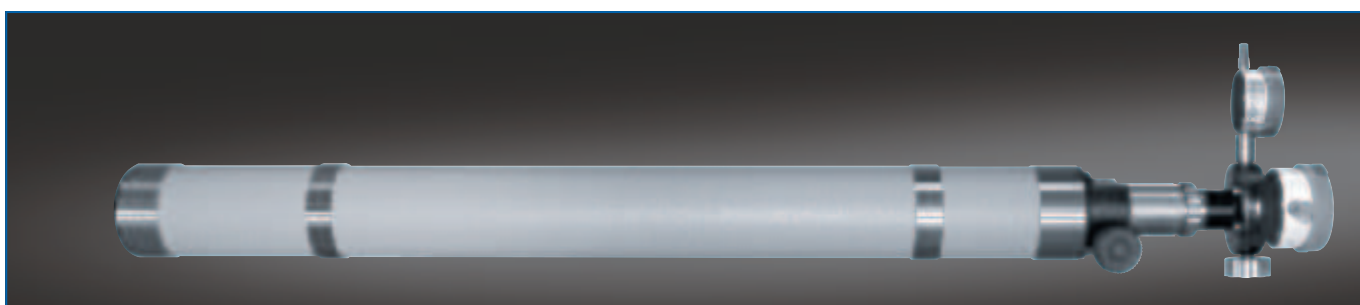

Ord.-No.	Description	Focal length	clear aperture	Tube extension	Meas. range	Resolution	Distance range	L
227 696	FGV 1100/105/14,7/±50 MDD	1100	78	±50	0,5°	0,1"	- ...-23,7 m 25,8 m...+	161±50
227 697	FGV 1100/105/14,7/+100 MDD	1100	78	+100	0,5°	0,1"	13,2 m...+	161 ⁺¹⁰⁰
227 698	FGV 1100/105/14,7/-100 MDD	1100	78	-100	0,5°	0,5"	- ...-12,0 m	161 ⁻¹⁰⁰

AUTOCOLLIMATORS

INTRODUCTION

Layout and principle of operation

An autocollimation telescope (autocollimator) combines the function of a collimator and a telescope in one unit. The collimator and telescope share the same optical path, which is accomplished using either a physical or geometrical beam splitter.

The illustration below shows the schematic set-up of an autocollimator with straight viewing, a physical beam splitter and infinity adjustment. The autocollimation telescope projects the image of the collimator reticle to infinity. A target mirror, located in the beam path of the autocollimator objective, returns the projected image into the autocollimator and creates an image of the collimator reticle via the beam splitter in the eyepiece reticle plane (autocollimation image).

The mechanical (objective tube) axis is adjusted to the optical axis with angle accuracy of $\pm 30 \mu\text{m} / f$ for autocollimators with f 300 mm. The reticle adjustment amount $\pm 10 \mu\text{m}$.

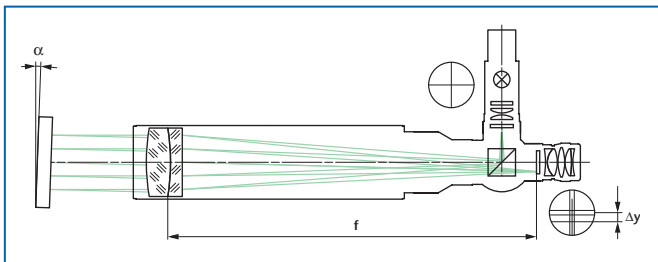

An autocollimator with geometrical beam splitter is arranged similarly (see illustration below). The collimator reticle is reflected into the beam path by the path-folding mirror which has a small angle in relation to the optical axis. The beam reflected off the target mirror passes below the path-folding mirror and produces an image of the collimator reticle in the eyepiece reticle plane.

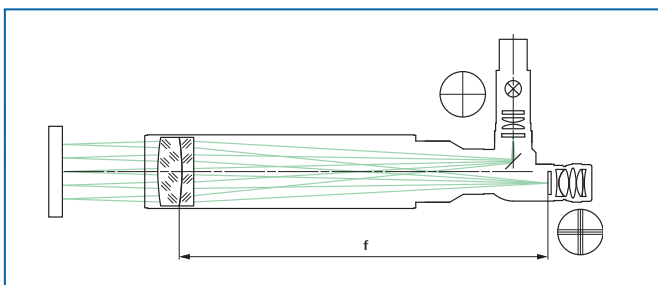

Calculation of the angles

An autocollimator can be used to measure the angle of a mirror in two axes with respect to the optical axis of the autocollimator. If the mirror is exactly perpendicular to the optical axis, the beam is reflected upon itself. If the mirror is tilted by the angles α_x and α_y , the reflected beam enters the objective obliquely. Depending on the amount of tilt, the autocollimation image in the eyepiece reticle plane is displaced to a greater or lesser amount. The displacement Δx and Δy of the autocollimation image in X and Y direction provides a measure of the angular displacement of the mirror:

$$\alpha_x = \arctan\left(\frac{\Delta x}{2f}\right) \quad \frac{\Delta x}{2f}$$

$$\alpha_y = \arctan\left(\frac{\Delta y}{2f}\right) \quad \frac{\Delta y}{2f}$$

f : focal length of the autocollimation objective.

Numerical example:

A displacement of the reticle image of 3 mm measured with an autocollimator with 300 mm focal length corresponds to a tilting angle of:

$$\alpha \quad 3/2/300 \text{ rad} = 5 \cdot 10^{-3} \text{ rad} = 0,2865^\circ = 17'11''$$

The image displacement of 10 μm in the reticle plane corresponds to an angular tilt of:

Focal length	Angular tilt
50 mm	21"
90 mm	11"
140 mm	7,4"
200 mm	5,2"
300 mm	3,4"
500 mm	2,1"
600 mm	1,7"
1100 mm	0,9"

Adjustable Focus

Autocollimators with adjustable distance between reticle and objective are also available. This adjustment allows objective focus at distances other than infinity. If the reticle is displaced out of the focal plane by a distance z' , then the autocollimator is focused at a distance a according to:

$$a = \frac{f^2 + z'f}{z'}$$

$z' < 0$ corresponds to a decrease of the distance between objective and reticle. The resulting image distance is negative (virtual object position) (a).

$z' > 0$ corresponds to a real image with positive object distance (c).

$z' = 0$ produces an image at infinite distance (b).

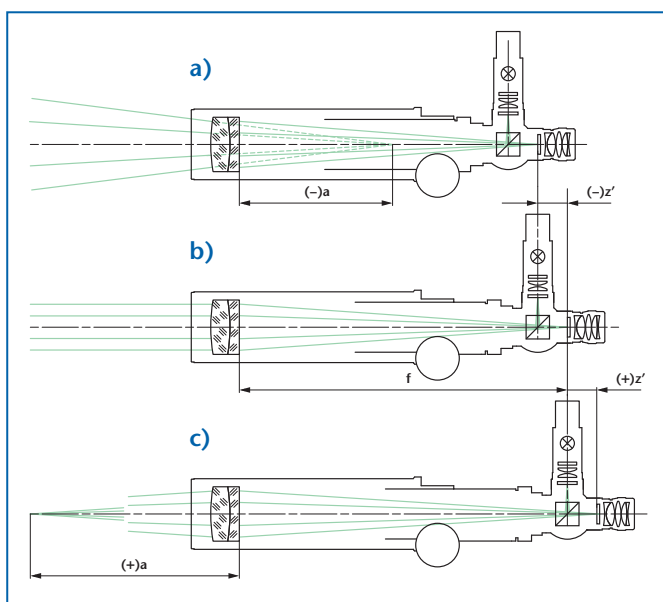

Selection criteria

Long or short focal length?

Depending on the magnification of the instrument a longer focal length leads to a greater measuring sensitivity and measurement accuracy. As the focal length increases, the measuring range decreases proportionally. A longer focal length affects the mechanical extension of the tube, as well.

Small or large objective aperture?

Light conditions are more favourable when large apertures are used, and the evaluation of the results is easier and more accurate. A long distance between mirror and autocollimator or a partially reflective surface demands a relatively large clear aperture (or aperture ratio). For these measurements a relatively large aperture diameter should be used.

Geometrical or physical beam splitter?

The geometrical beam splitter results in smaller image angles, but greater image brightness and less stray light. These autocollimators are used mainly with small targets. Due to their internal layout, these autocollimators cannot be used for measurement of triple mirrors or corner cubes. In most cases an autocollimator with physical beam splitter is recommended, due to the larger measuring range of this configuration.

Fixed or variable distance setting?

The measurement of the angles of plane mirrors in autocollimation is made with a parallel, or infinity focus, beam. Fixed, infinite focus is generally the best choice. For measurement tasks requiring an adjustable focal distance, use an objective tube with focus adjustment. Fixed focus tubes set at other than infinity can be ordered.

Eyepiece focal length?

In contrast to eyepiece with $f=14,7$ mm eyepiece with $f=10$ mm gives a larger magnification but lesser FOV and eyepiece with $f=25$ mm gives a smaller magnification but larger FOV. In case a C-Mount-Camera adapter should be used, the eyepieces $f=14,7$ or $f=25$ mm has to be selected.

AUTOCOLLIMATORS

STRAIGHT VIEWING

Description:

For a general description of the principle of functioning see page 42.

An autocollimator with straight viewing has the user's line of sight co-linear with the objective axis. These autocollimators are preferably used in horizontal direction, where the eyepiece is at eye level. In a down-looking arrangement or on optical table 90°- or 60°-viewing is often more suitable.

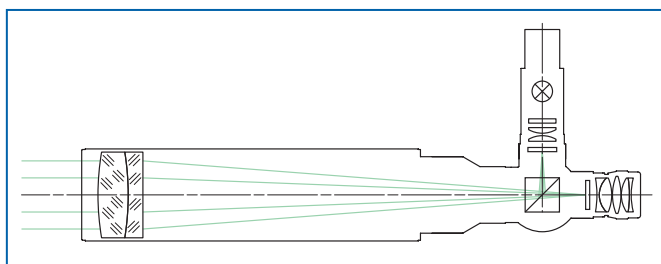

Application areas:

- Measurement of angular tilt
- Measurement of parallelism of plane plates
- Adjustment of optical elements
- Qualitative testing of the imaging properties of optical elements and systems

Notes on ordering:

- Optionally, the autocollimators can be equipped with an eyepiece having 10 mm or 25 mm focal length.
- Two reticles, 6V/5W illumination w/cord, and eyepiece are included.
- If not specified otherwise, the autocollimator is adjusted to infinity at 546 nm wavelength. Adjustment to other distances or wavelengths is also possible on demand.
- The nomenclature of the autocollimators with straight viewing is as follows:

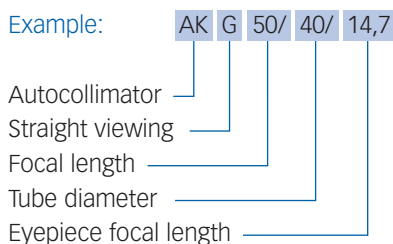

Important:

Please specify collimator reticle and eyepiece reticle (see page 82) as well as illumination (LED-, bulb- or cold light, see page 81) when ordering.

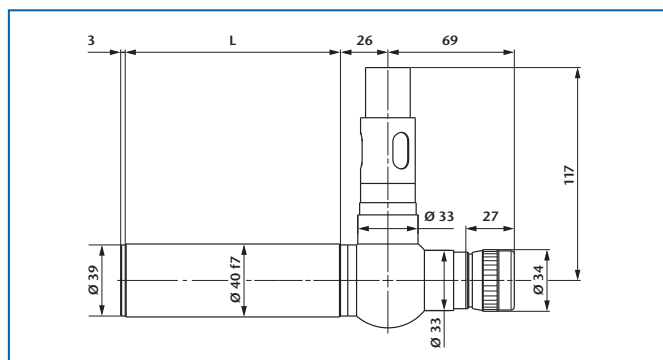

Ord.-No.	Description	Focal length	clear aperture	Meas. range	L
229 001	AKG 50/40/14,7	50	10	5,0°	65
229 002	AKG 90/40/14,7	90	16	3,0°	65
229 003	AKG 140/40/14,7	140	28	2,0°	118
229 004	AKG 200/40/14,7	200	28	1,5°	173
229 005	AKG 300/40/14,7	300	28	1,0°	274
229 006	AKG 500/40/14,7	500	28	0,5°	474



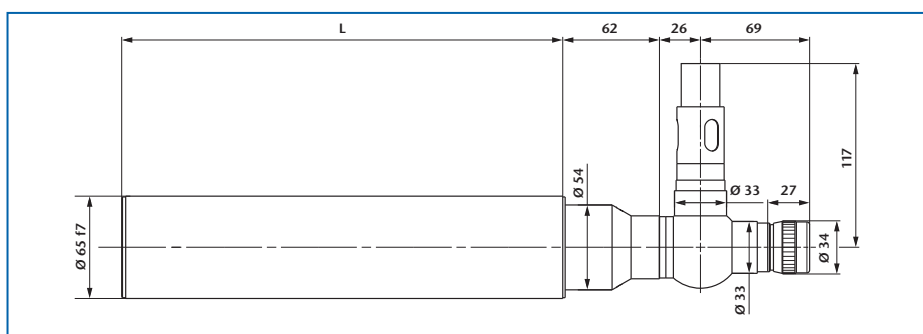
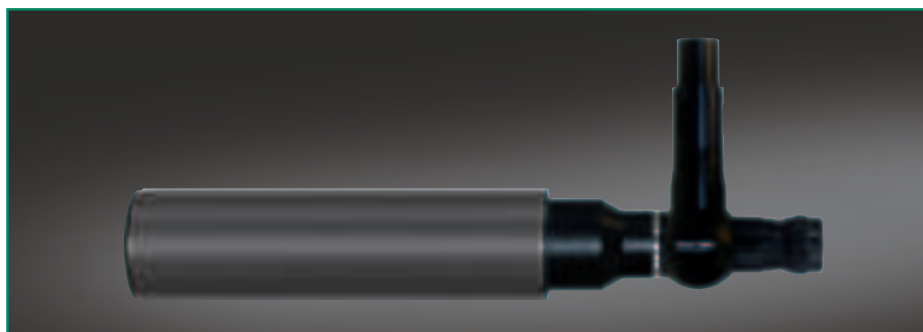

Ord.-No.	Description	Focal length	clear aperture	Meas. range	L
229 007	AKG 300/65/14,7	300	50	1,0°	233
229 008	AKG 500/65/14,7	500	50	0,5°	415
229 010	AKG 500T/65/14,7	500	50	0,5°	233

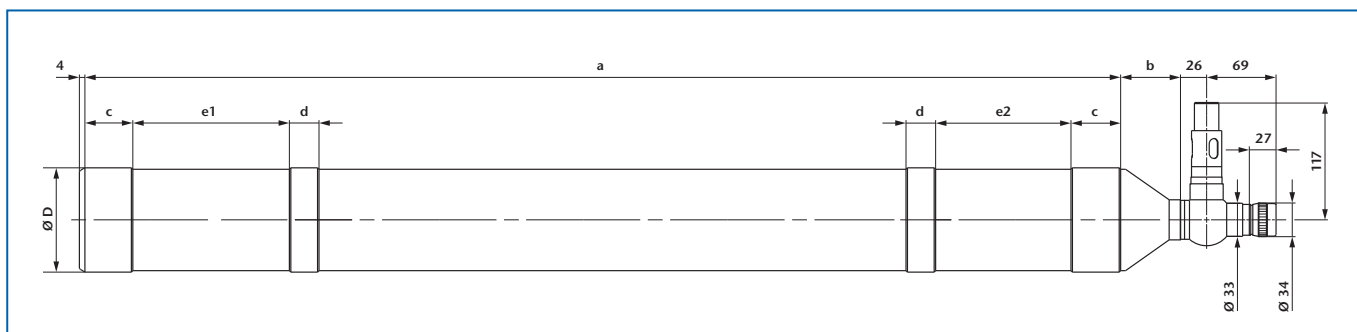
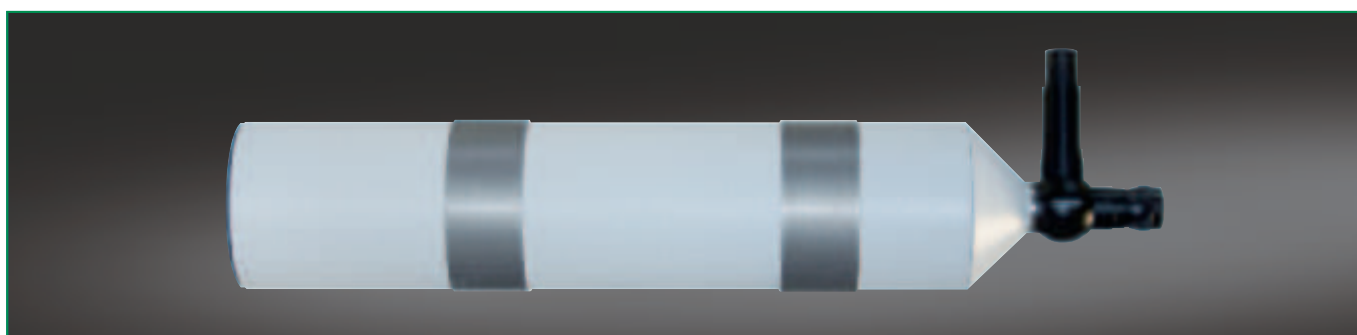

Ord.-No.	Description	Focal length	clear aperture	Meas. range	D	a	b	c	d	e1	e2
229 012	AKG 600/128/14,7	600	100	0,40°	Ø 128 f7	530	46	-	58	154	78
229 013	AKG 1100/105/14,7	1100	78	0,25°	Ø 105 f7	1045	66	50	30	165	100

AUTOCOLLIMATORS

90°-VIEWING

Description:

For a general description of the principle of functioning see page 42.

An autocollimator with right angle viewing has the user's line of sight at 90° to the objective axis. These autocollimators are preferably used down-looking and on optical tables where a straight viewing is not feasible.

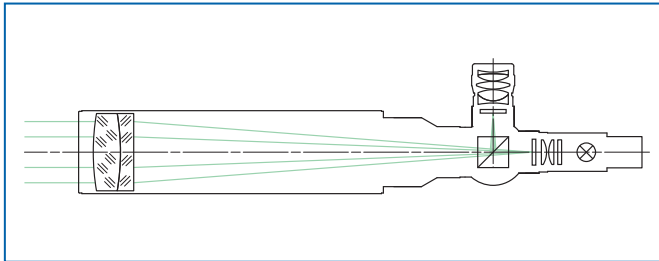

Application areas:

- Measurement of angular tilt
- Measurement of parallelism of plane plates
- Adjustment of optical elements
- Qualitative testing of the imaging properties of optical elements and systems

Notes on ordering:

- Optionally, the autocollimators can be equipped with an eyepiece having 10 mm or 25 mm focal length.
- Two reticles, 6V/5W illumination w/cord, and eyepiece are included.
- If not specified otherwise, the autocollimator is adjusted to infinity at 546 nm wavelength. Adjustment to other distances or wavelengths is also possible on demand.
- The nomenclature of the autocollimators with 90°-viewing is as follows:

Example: **AK R 50/ 40/ 14,7**

Autocollimator — AK
 90° viewing — R
 Focal length — 50/
 Tube diameter — 40/
 Eyepiece focal length — 14,7

Important:

Please specify collimator reticle and eyepiece reticle (see page 82) as well as illumination (LED-, bulb- or cold light, see page 81) when ordering. Please specify direction of use if reticles with lettering (e.g. coordinate division etc.) are used so that the lettering will be right-side-up.

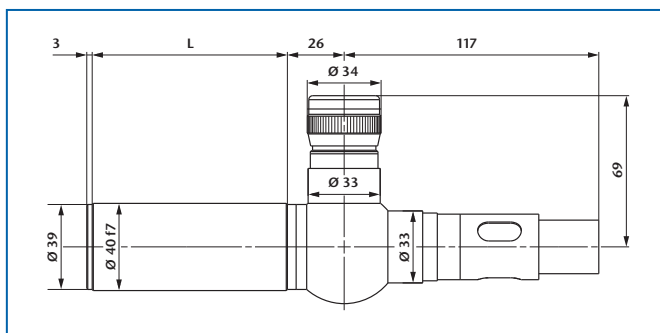

Ord.-No.	Description	Focal length	clear aperture	Meas. range	L
229 201	AKR 50/40/14,7	50	10	5,0°	65
229 202	AKR 90/40/14,7	90	16	3,0°	65
229 203	AKR 140/40/14,7	140	28	2,0°	118
229 204	AKR 200/40/14,7	200	28	1,5°	173
229 205	AKR 300/40/14,7	300	28	1,0°	274
229 206	AKR 500/40/14,7	500	28	0,5°	474



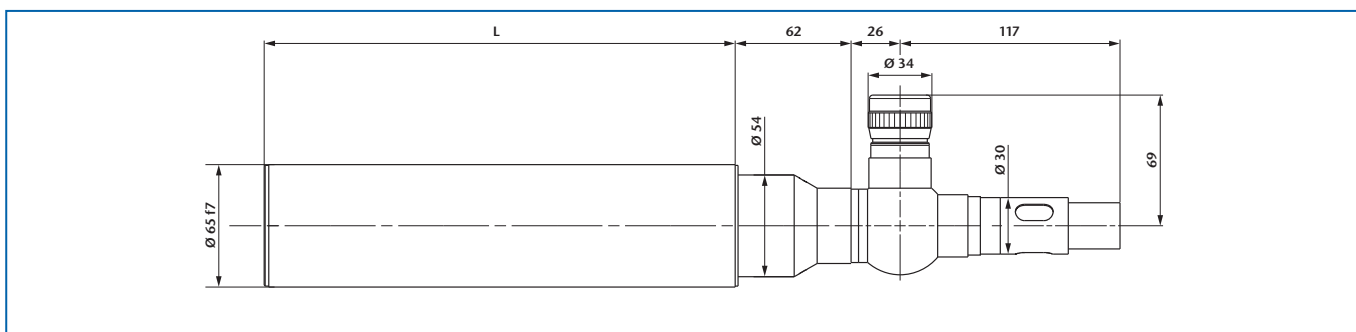
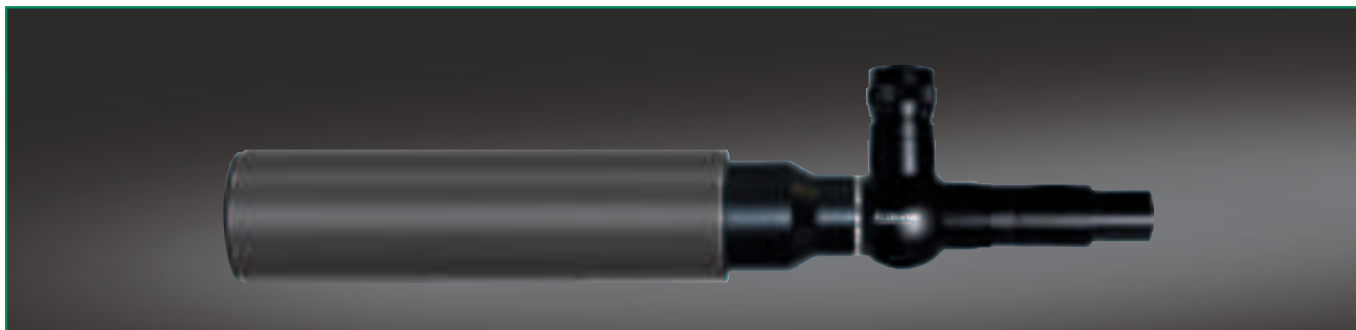

Ord.-No.	Description	Focal length	clear aperture	Meas. range	L
229 207	AKR 300/65/14,7	300	50	1,0°	233
229 208	AKR 500/65/14,7	500	50	0,5°	415
229 210	AKR 500T/65/14,7	500	50	0,5°	233

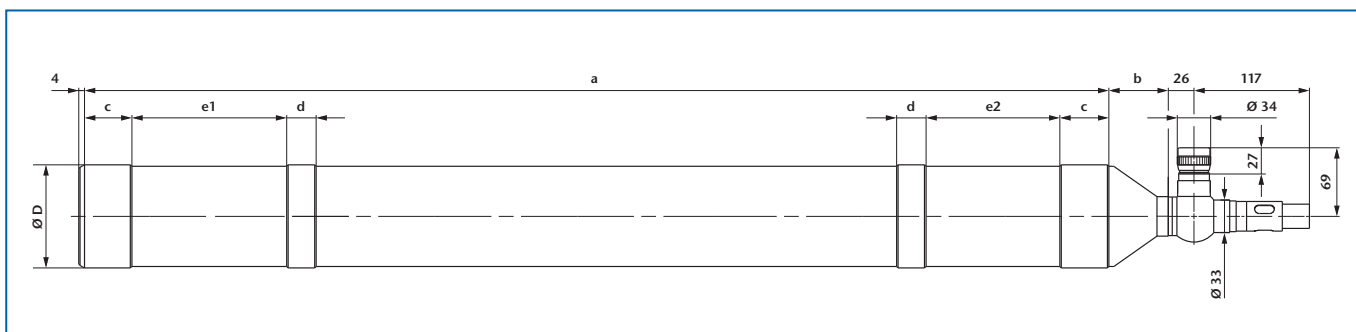
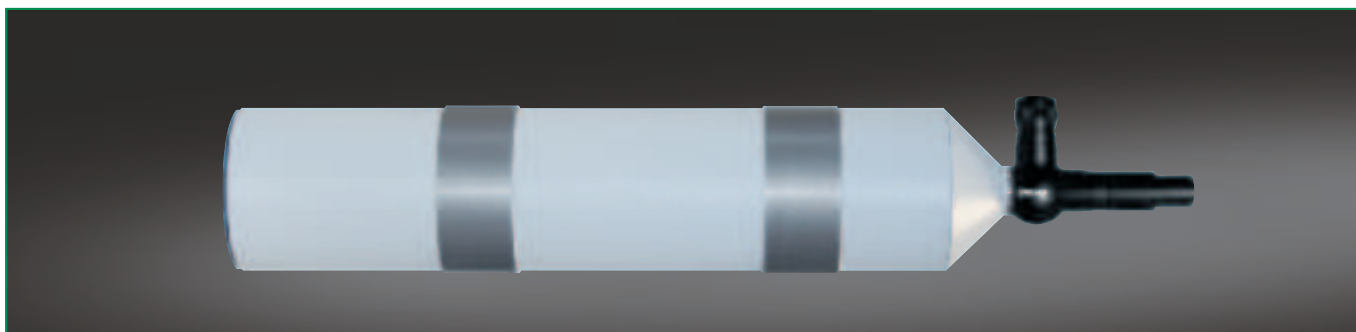

Ord.-No.	Description	Focal length	clear aperture	Meas. range	D	a	b	c	d	e1	e2
229 212	AKR 600/128/14,7	600	100	0,40°	Ø 128 f7	530	46	-	58	154	78
229 213	AKR 1100/105/14,7	1100	78	0,25°	Ø 105 f7	1045	66	50	30	165	100

AUTOCOLLIMATORS

60°-VIEWING/60°-VIEWING WITH DOUBLE MICROMETER

Description:

The function and layout resemble an autocollimator with 90°-viewing (see page 46).

The 60°-viewing is used in a horizontal position where the angled eyepiece is more ergonomic. In addition to the standard autocollimator with collimator and eyepiece reticle (see fig. A) versions with mechanical (see fig. B) or digital micrometer (see fig. C) are available as well.

For a general description of the principle of functioning of autocollimators with double micrometer see page 42 or 54, too.

The scale division (SD) of the mechanical double micrometer is 5 μm .

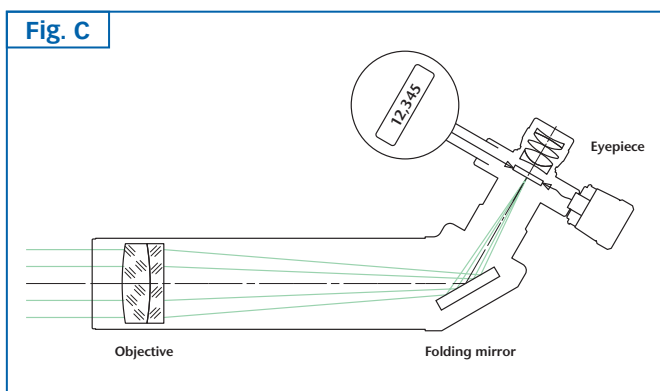
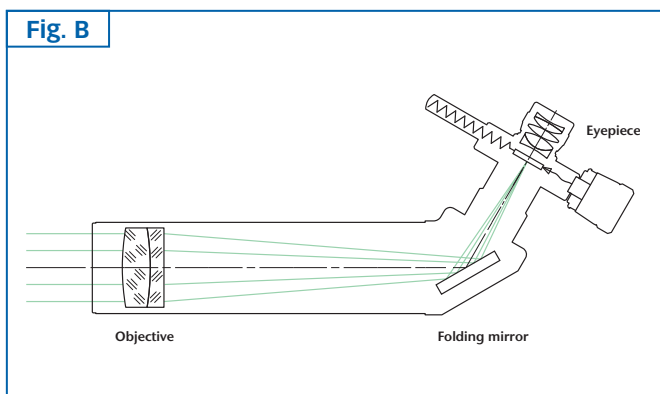
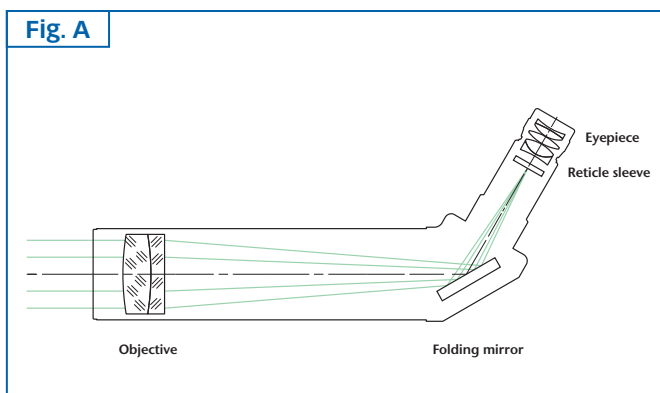

Application areas:

- Measurement of angular tilt
- Measurement of parallelism of plane plates
- Adjustment of optical elements
- Qualitative testing of the imaging properties of optical elements and systems

Notes on ordering:

- Optionally, the autocollimators can be equipped with an eyepiece having 10 mm or 25 mm focal length.
- Two reticles, 6V/5W illumination w/cord, and eyepiece are included.
- If not specified otherwise, the autocollimator is adjusted to infinity at 546 nm wavelength. Adjustment to other distances or wavelengths is also possible on demand.
- Specify the unit of display of the digital gauges (mm, arcsec oder mrad).
- The nomenclature of the autocollimators with 60°-viewing and 60° viewing with double micrometer respectively is as follows:

Example:

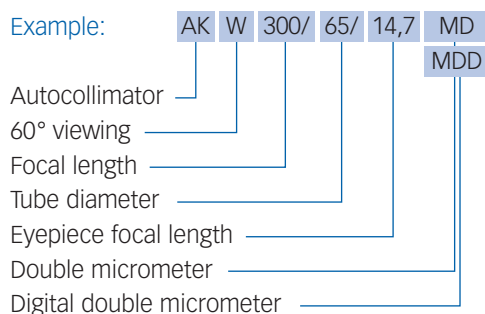

Important:

Please specify collimator reticle and eyepiece reticle (see page 82) as well as illumination (LED-, bulb- or cold light, see page 81) when ordering.

60°-VIEWING

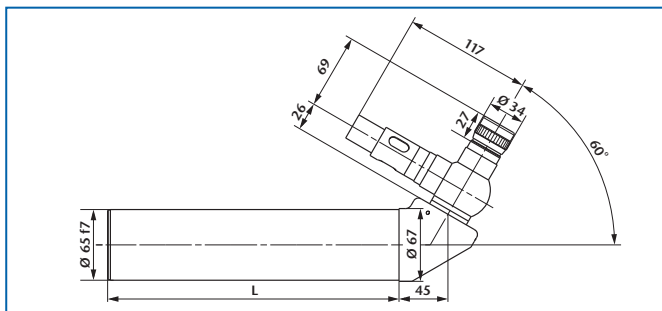

Ord.-No.	Description	Focal length	clear aperture	Meas. range	L
229 027	AKW 300/65/14,7	300	50	1,0°	233
229 028	AKW 500/65/14,7	500	50	0,5°	415
229 030	AKW 500T/65/14,7	500	50	0,5°	233

60°-VIEWING WITH DOUBLE MICROMETER

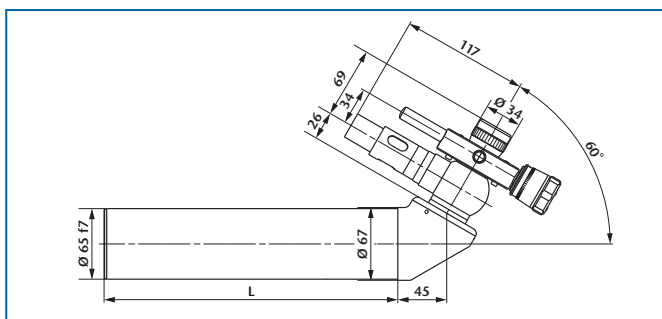

Ord.-No.	Description	Focal length	clear aperture	Meas. range	SD	L
229 169	AKW 300/65/14,7 MD	300	50	0,3°	2,0"	233
229 170	AKW 500/65/14,7 MD	500	50	0,2°	1,0"	415
229 171	AKW 500T/65/14,7 MD	500	50	0,2°	1,0"	233

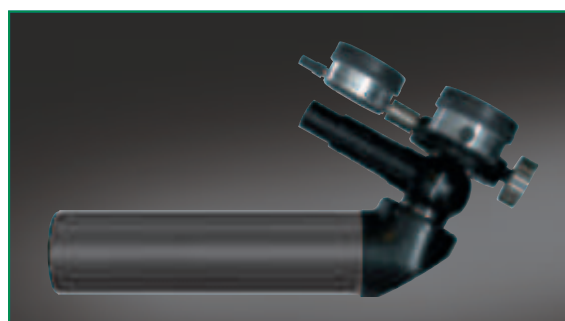
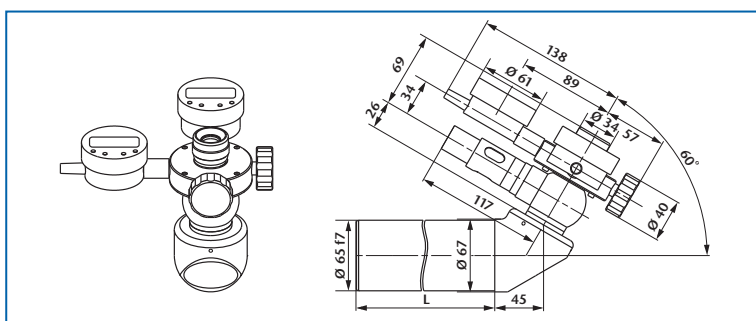

Ord.-No.	Description	Focal length	clear aperture	Meas. range	Resolution	L
229 107	AKW 300/65/14,7 MDD	300	50	0,50°	0,5 arcsec	233
229 108	AKW 500/65/14,7 MDD	500	50	0,25°	0,2 arcsec	415
229 110	AKW 500T/65/14,7 MDD	500	50	0,25°	0,2 arcsec	233

AUTOCOLLIMATORS

STRAIGHT VIEWING – WITH DOUBLE MICROMETER

Description:

For a general description of the principle of functioning see page 42.

An autocollimator with a micrometer driven eyepiece reticle can directly read reticle displacement for higher accuracy compared to a fixed reticle. By using the formula given on page 42 this displacement can be converted into angular tilt of the reflector. The scale division (SD) of the micrometer drums is 5 μm .

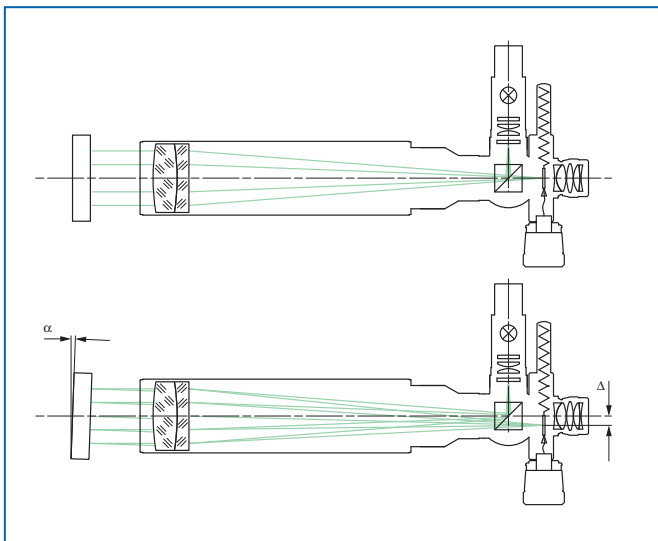

Notes on ordering:

- Optionally, the autocollimators can be equipped with an eyepiece having 10 mm or 25 mm focal length.
- Two reticles, 6V/5W illumination w/cord, and eyepiece are included.
- If not specified otherwise, the autocollimator is adjusted to infinity at 546 nm wavelength. Adjustment to other distances or wavelengths is also possible on demand.
- The nomenclature of the autocollimators with straight viewing and double micrometer is as follows:

Example: **AK G 50/ 40/ 14,7 MD**

Autocollimator — AK
 Straight viewing — G
 Focal length — 50/
 Tube diameter — 40/
 Eyepiece focal length — 14,7
 Double micrometer — MD

Important:

Please specify collimator reticle and eyepiece reticle (see page 82) as well as illumination (LED-, bulb- or cold light, see page 81) when ordering.

Application areas:

- Measurement of angular tilt
- Measurement of parallelism of plane plates
- Straightness measurement of guide ways (manually)

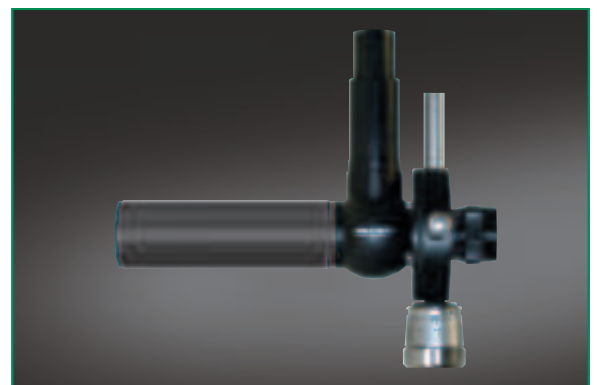
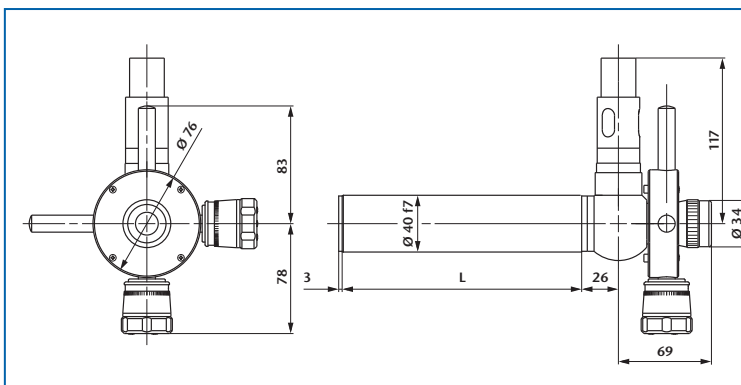

Ord.-No.	Description	Focal length	clear aperture	Meas. range	SD	L
229 155	AKG 50/40/14,7 MD	50	10	1,6°	20,0"	65
229 156	AKG 90/40/14,7 MD	90	16	1,0°	11,5"	65
229 157	AKG 140/40/14,7 MD	140	28	0,6°	7,5"	118
229 158	AKG 200/40/14,7 MD	200	28	0,4°	5,0"	173
229 159	AKG 300/40/14,7 MD	300	28	0,3°	3,5"	274
229 160	AKG 500/40/14,7 MD	500	28	0,2°	2,0"	474

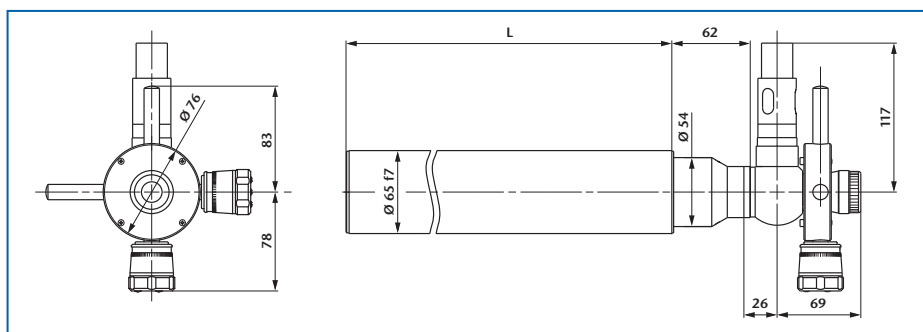
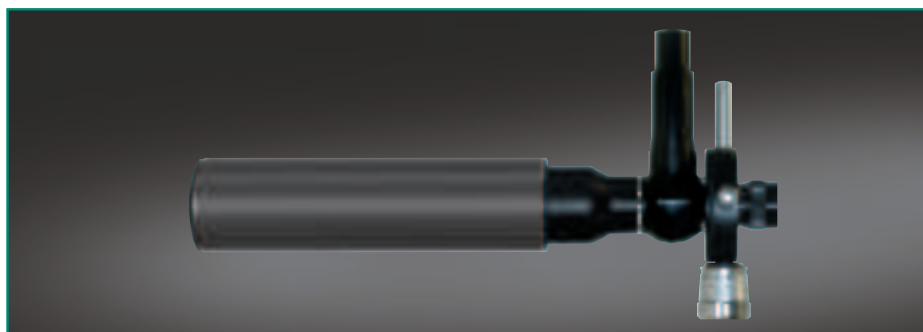

Ord.-No.	Description	Focal length	clear aperture	Meas. range	SD	L
229 161	AKG 300/65/14,7 MD	300	50	0,3°	2,0"	233
229 162	AKG 500/65/14,7 MD	500	50	0,2°	1,0"	415
229 163	AKG 500T/65/14,7 MD	500	50	0,2°	1,0"	233

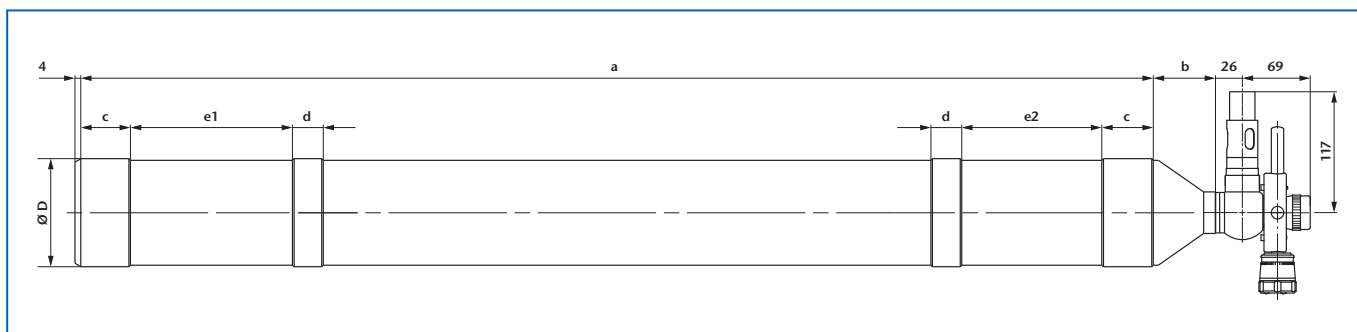

Ord.-No.	Description	Focal length	clear aperture	Meas. range	SD	D	a	b	c	d	e1	e2
229 165	AKG 600/128/14,7 MD	600	100	0,15°	0,85"	Ø 128 f7	530	46	-	58	154	100
229 164	AKG 1100/105/14,7 MD	1100	78	0,08°	0,50"	Ø 105 f7	1045	66	50	30	165	78

AUTOCOLLIMATORS

90°-VIEWING – WITH DOUBLE MICROMETER

Description:

For a general description of the principle of functioning see page 42.

An autocollimator with a micrometer driven eyepiece reticle can directly read reticle displacement for higher accuracy compared to a fixed reticle. By using the formula given on page 42 this displacement can be converted into angular tilt of the reflector. The scale division (SD) of the micrometer drums is 5 μm .

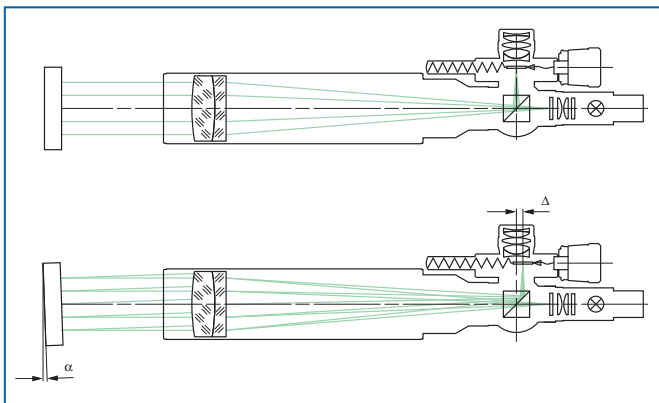

Application areas:

- Measurement of angular tilt
- Measurement of parallelism of plane plates
- Straightness measurement of guide ways (manually)

Notes on ordering:

- Optionally, the autocollimators can be equipped with an eyepiece having 10 mm or 25 mm focal length.
- Two reticles, 6V/5W illumination w/cord, and eyepiece are included.
- If not specified otherwise, the autocollimator is adjusted to infinity at 546 nm wavelength. Adjustment to other distances or wavelengths is also possible on demand.
- The nomenclature of the autocollimators with 90°-viewing and double micrometer is as follows:

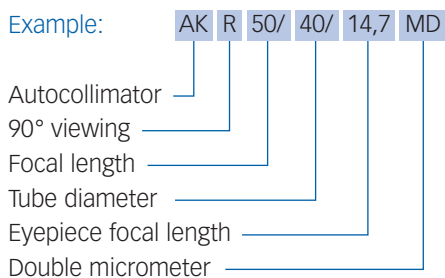

Important:

Please specify collimator reticle and eyepiece reticle (see page 82) as well as illumination (LED-, bulb- or cold light, see page 81) when ordering.

Please specify direction of use if reticles with lettering (e.g. coordinate division etc.) are used so that the lettering will be right-side-up.



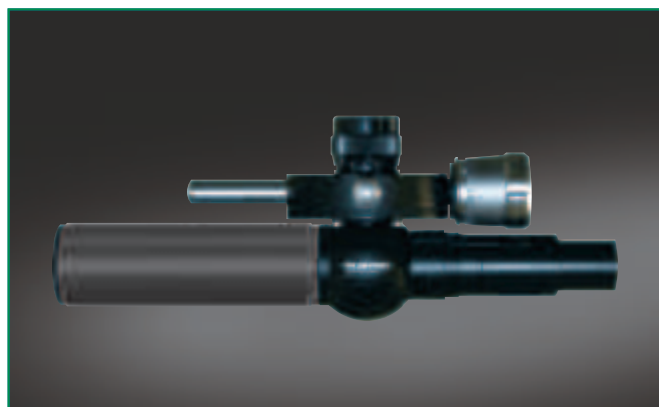
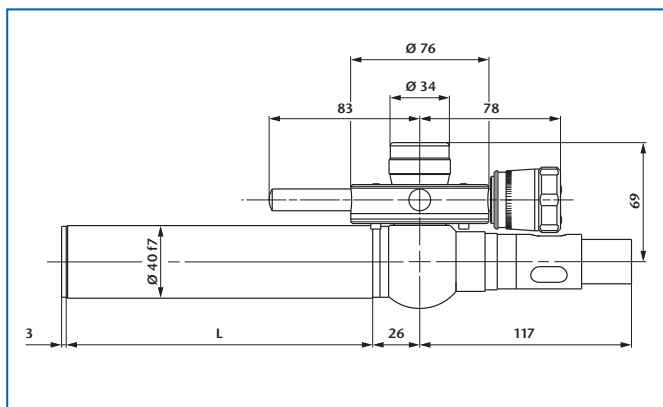

Ord.-No.	Description	Focal length	clear aperture	Meas. range	SD	L
229 271	AKR 50/40/14,7 MD	50	10	1,6°	10,0"	65
229 272	AKR 90/40/14,7 MD	90	16	1,0°	5,5"	65
229 273	AKR 140/40/14,7 MD	140	28	0,6°	3,5"	118
229 274	AKR 200/40/14,7 MD	200	28	0,4°	2,5"	173
229 275	AKR 300/40/14,7 MD	300	28	0,3°	2,0"	274
229 276	AKR 500/40/14,7 MD	500	28	0,2°	1,0"	474

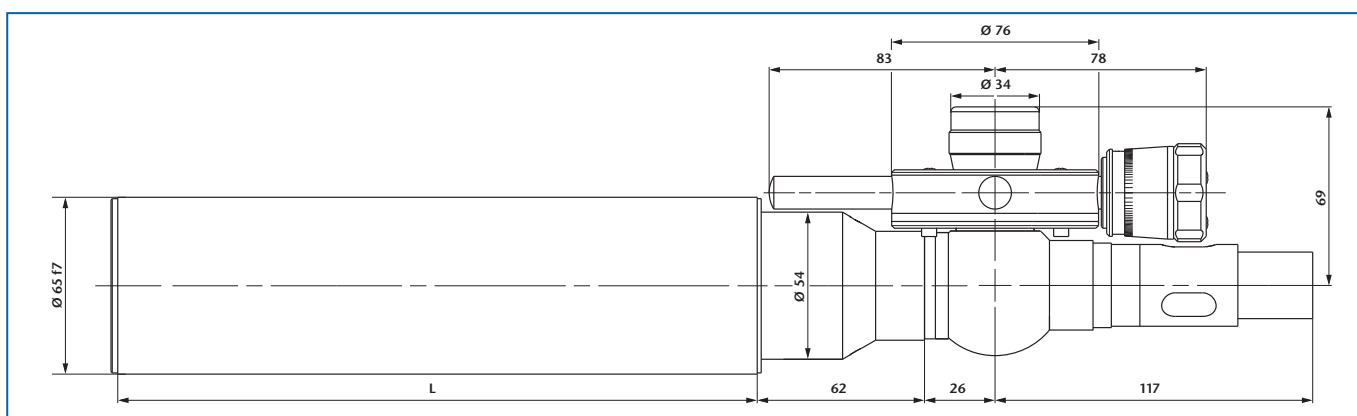
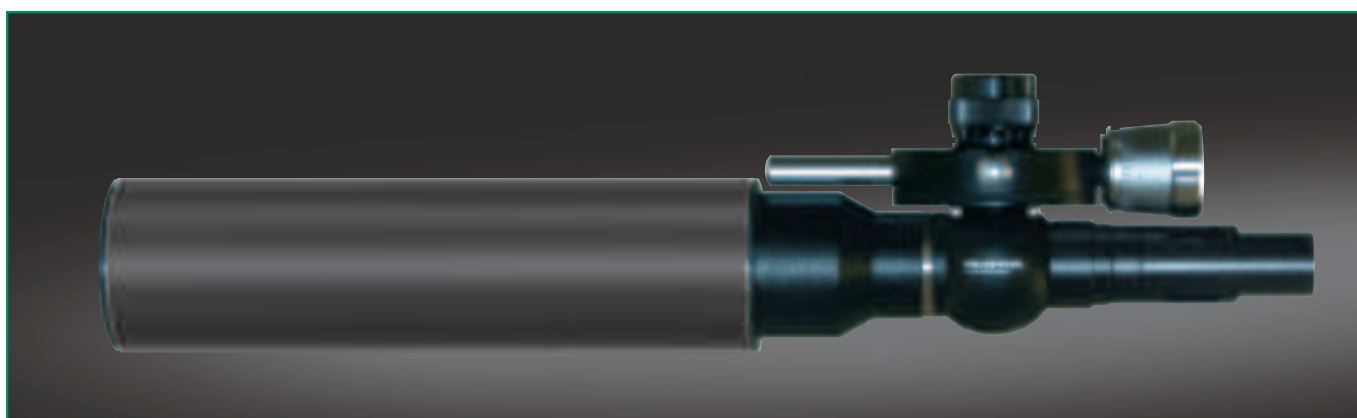

Ord.-No.	Description	Focal length	clear aperture	Meas. range	SD	L
229 277	AKR 300/65/14,7 MD	300	50	0,3°	2,0"	233
229 278	AKR 500/65/14,7 MD	500	50	0,2°	1,0"	415
229 280	AKR 500T/65/14,7 MD	500	50	0,2°	1,0"	233

AUTOCOLLIMATORS

STRAIGHT VIEWING – WITH DIGITAL DOUBLE MICROMETER

Description:

For a general description of the principle of functioning see page 42.

An autocollimator with a micrometer driven eyepiece reticle can directly read reticle displacement for higher accuracy compared to a fixed reticle.

In place of the micrometer drums above, optionally, programmable digital gauges allow direct reading of the tilting angle in arcsec or milliradians (see page 42 for converting the displacement into angular tilt of the reflector).

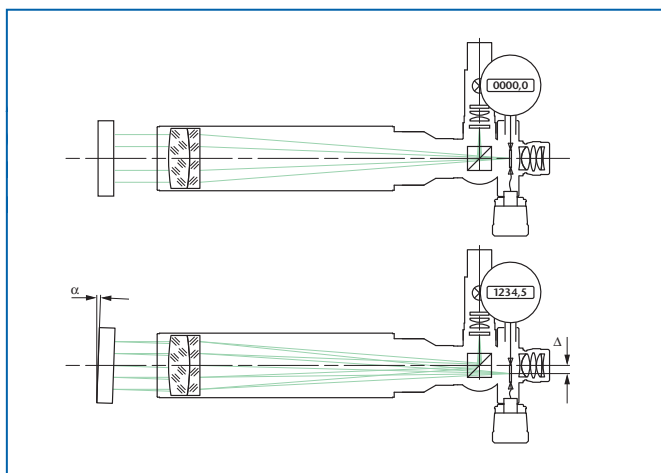

Application areas:

- Measurement of angular tilt
- Measurement of parallelism of plane plates

Notes on ordering:

- Optionally, the autocollimators can be equipped with an eyepiece having 10 mm or 25 mm focal length.
- Two reticles, 6V/5W illumination w/cord, and eyepiece are included.
- If not specified otherwise, the autocollimator is adjusted to infinity at 546 nm wavelength. Adjustment to other distances or wavelengths is also possible on demand.
- Specify the unit of display of the digital gauges (mm, arcsec, milliradians).
- The nomenclature of the autocollimators with straight viewing and digital double micrometer is as follows:

Example:

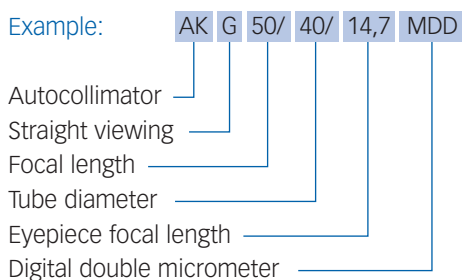

Important:

Please specify collimator reticle and eyepiece reticle (see page 82) as well as illumination (LED-, bulb- or cold light, see page 81) when ordering.

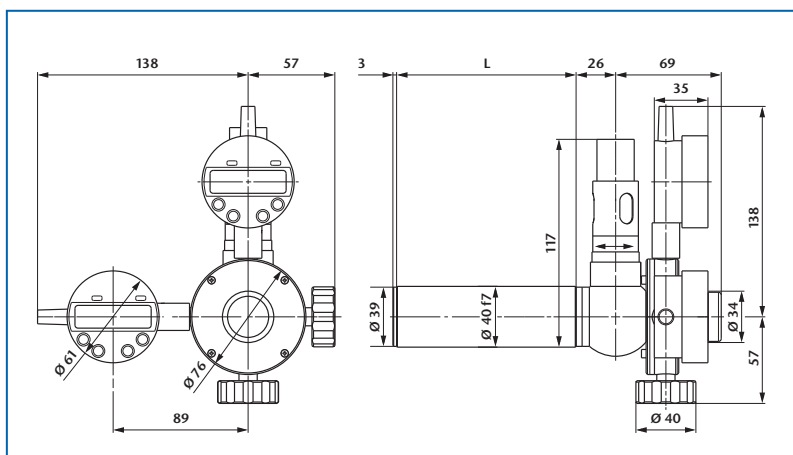

Ord.-No.	Description	Focal length	clear aperture	Meas. range	Resolution	L
229 081	AKG 50/40/14,7 MDD	50	10	2,80°	2,0"	65
229 082	AKG 90/40/14,7 MDD	90	16	1,50°	1,0"	65
229 083	AKG 140/40/14,7 MDD	140	28	1,00°	1,0"	118
229 084	AKG 200/40/14,7 MDD	200	28	0,70°	0,5"	173
229 085	AKG 300/40/14,7 MDD	300	28	0,50°	0,5"	274
229 086	AKG 500/40/14,7 MDD	500	28	0,25°	0,2"	474

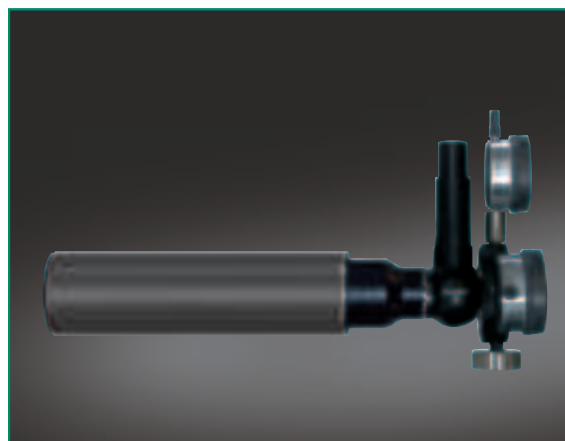
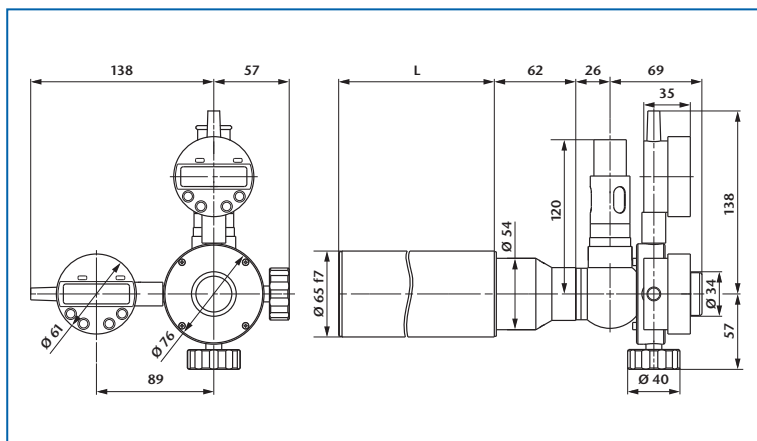

Ord.-No.	Description	Focal length	clear aperture	Meas. range	Resolution	L
229 087	AKG 300/65/14,7 MDD	300	50	0,50°	0,5"	233
229 088	AKG 500/65/14,7 MDD	500	50	0,25°	0,2"	415
229 090	AKG 500T/65/14,7 MDD	500	50	0,25°	0,2"	233

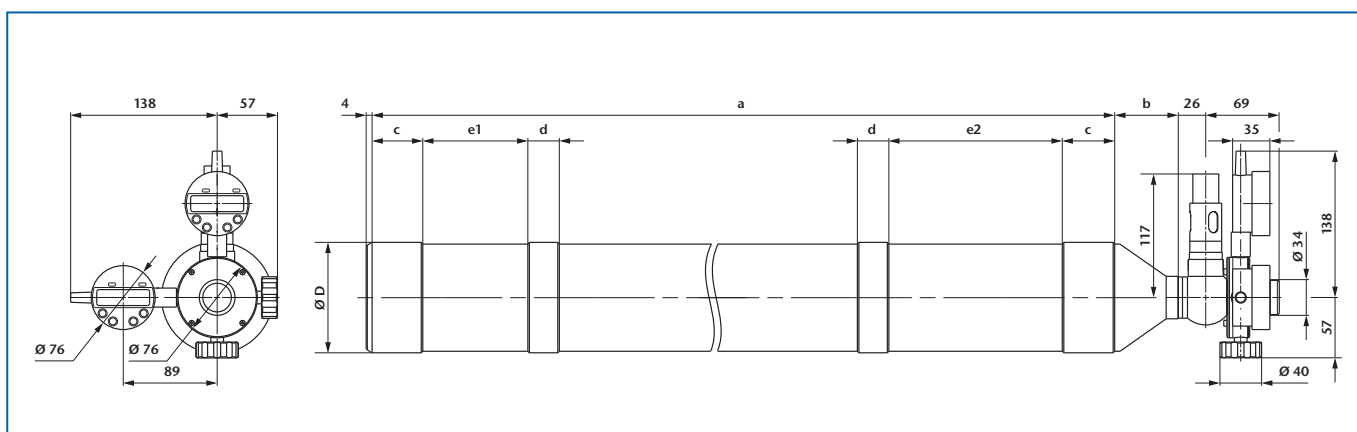
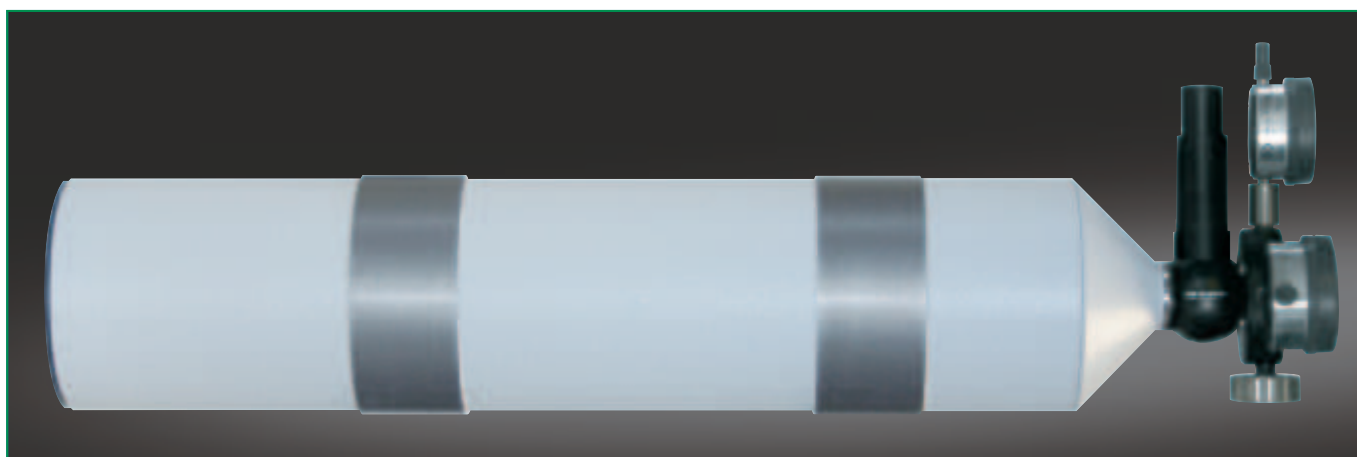

Ord.-No.	Description	Focal length	Free aperture	Meas. range	Resolution	D	a	b	c	d	e1	e2
229 092	AKG 600/128/14,7 MDD	600	100	0,20°	0,2"	Ø 128 f7	530	46	-	58	154	78
229 093	AKG 1100/105/14,7 MDD	1100	78	0,08°	0,1"	Ø 105 f7	1045	66	50	30	165	100

AUTOCOLLIMATORS

90°-VIEWING – WITH RETICLE TURRET

Description:

For a general description of the principle of functioning see page 42.

The autocollimator with reticle turret provides 6 selectable collimator reticles. The reticle turret allows fast switching between different measurement tasks.

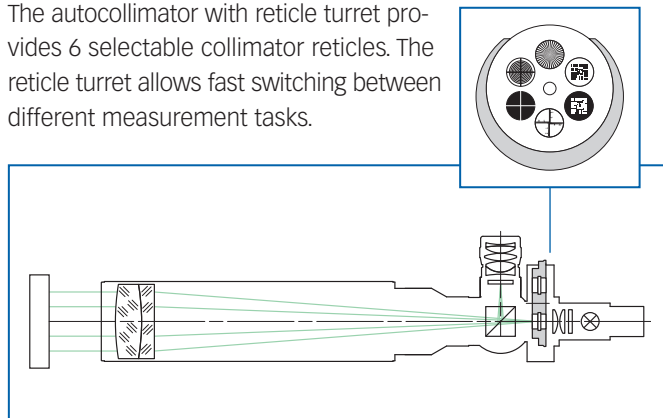

Application areas:

- Measurement of angular tilt
- Testing of the infinity setting of camera objectives
- Qualitative testing of the imaging properties of optical elements and systems
- Fast testing of wedges and plane parallel plates with pinhole diaphragm turret

Notes on ordering:

- Optionally, the autocollimators can be equipped with an eyepiece having 10 mm or 25 mm focal length.
- Reticles, 6V/5W illumination w/cord, and eyepiece are included.
- In contrast to autocollimators with only one collimator and one eyepiece reticle the optical axis can not be adjusted to its mechanical (tube) axis.
- If not specified otherwise, the autocollimator is adjusted to infinity at 546 nm wavelength. Adjustment to other distances or wavelengths is also possible on demand.
- The nomenclature of the autocollimators with 90°-viewing and with reticle turret is as follows:

Example: **AK R 50/ 40/ 14,7 SW**

Autocollimator
90° viewing
Focal length
Tube diameter
Eyepiece focal length
Reticle turret

Important:

Please specify six collimator reticles and one eyepiece reticle (see page 82) as well as illumination (LED-, bulb- or cold light, see page 81) when ordering. Please specify direction of use if reticles with lettering (e.g. coordinate division etc.) are used so that the lettering will be right-side-up.

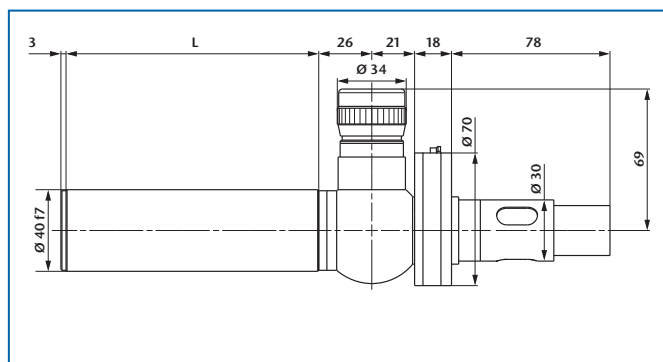

Ord.-No.	Description	Focal length	clear aperture	Meas. range	L
229 281	AKR 50/40/14,7 SW	50	10	5,0°	65
229 282	AKR 90/40/14,7 SW	90	16	3,0°	65
229 283	AKR 140/40/14,7 SW	140	28	2,0°	118
229 284	AKR 200/40/14,7 SW	200	28	1,5°	173
229 285	AKR 300/40/14,7 SW	300	28	1,0°	274
229 286	AKR 500/40/14,7 SW	500	28	0,5°	474

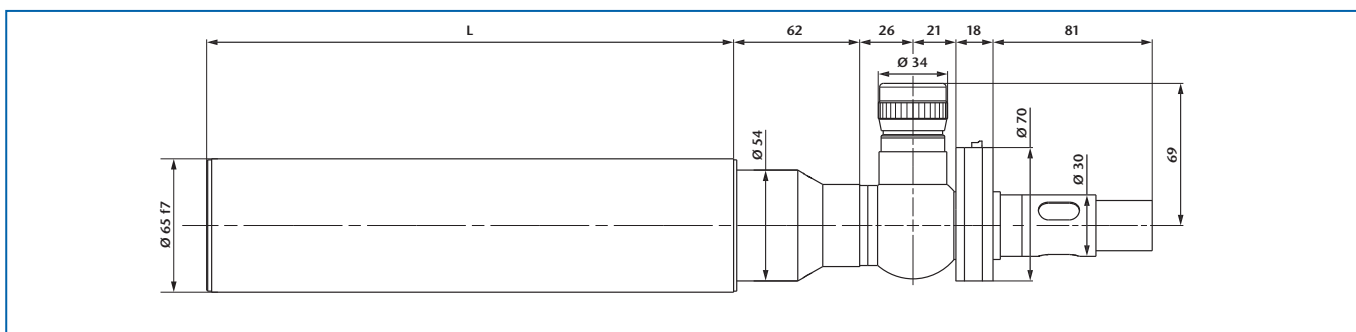

Ord.-No.	Description	Focal length	clear aperture	Meas. range	L
229 287	AKR 300/65/14,7 SW	300	50	1,0°	65
229 288	AKR 500/65/14,7 SW	500	50	0,5°	65
229 290	AKR 500T/65/14,7 SW	500	50	0,5°	118

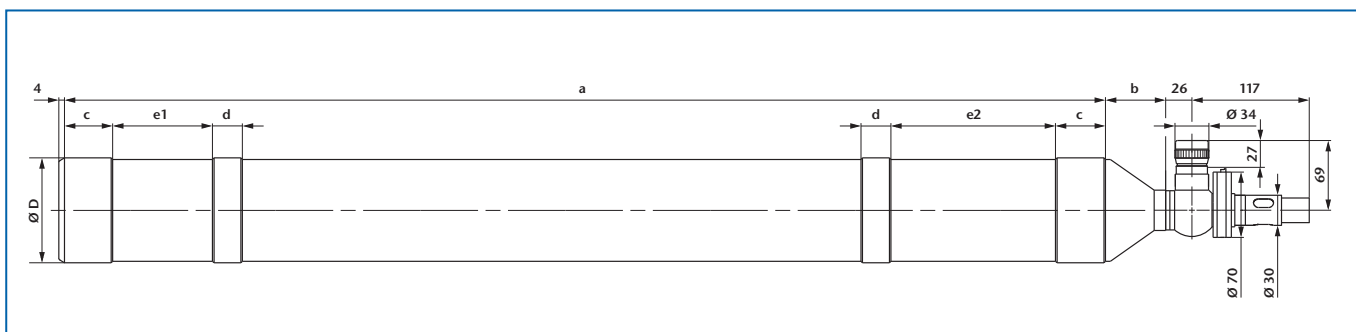
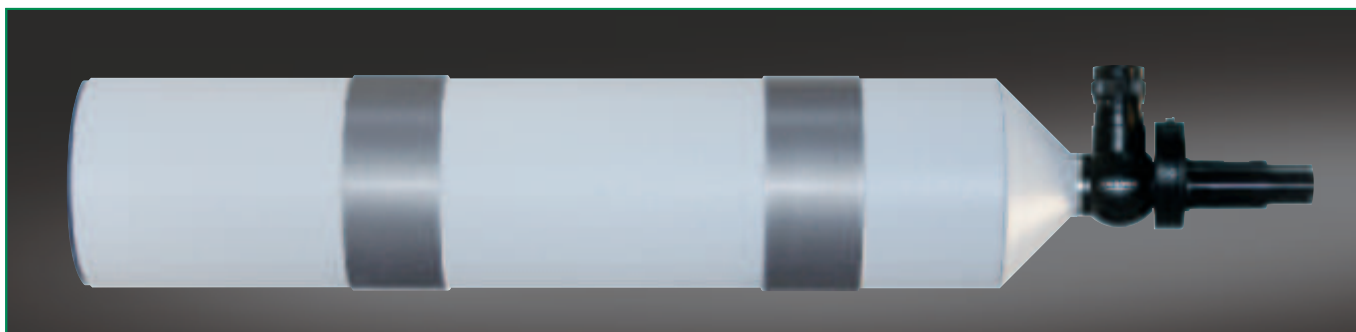

Ord.-No.	Description	Focal length	clear aperture	Meas. range	D	a	b	c	d	e1	e2
229 292	AKR 600/128/14,7 SW	600	100	0,40°	Ø 128 f7	530	46	-	58	154	78
229 293	AKR 1100/105/14,7 SW	1100	78	0,25°	Ø 105 f7	1045	66	50	30	165	100

AUTOCOLLIMATORS WITH CCD-CAMERA MOUNT

Description:

For a general description of the principle of functioning see page 42.

The principle, function and layout resemble the autocollimator with 90°-viewing (see page 46). The eyepiece and the eyepiece reticle are replaced by a mount for a CCD-camera and the autocollimation image is directly imaged on the camera chip when the camera is mounted. With no eyepiece reticle the displacement of the return image is measured on a video monitor or using a computer, frame grabber and software (see page 106).

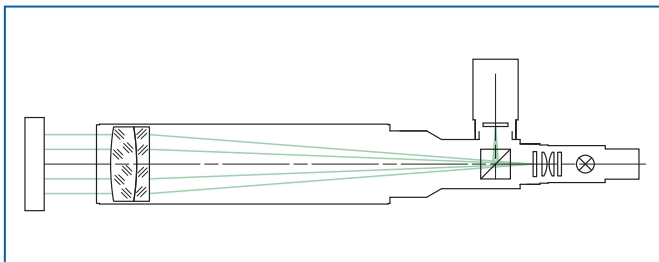

Application areas:

- Measurement of angular tilt
- Measurement of parallelism of plane plates
- Adjustment of optical elements
- Qualitative testing of the imaging properties of optical elements and systems

Notes on ordering:

- One Reticle and 6V/5W illumination w/cord are included.



More notes on ordering:

- **CCD-camera and computer hardware/software are NOT included.**
- As this type of autocollimator does not have an eyepiece reticle a direct measurement of the reticle displacement is impossible. Additional computer with software and frame grabber is needed.
- For angular measurement the autocollimator should be equipped with a negative crosshair reticle (see page 83). For testing of imaging quality use resolution target or Siemens Star (see page 87).
- If not specified otherwise, the autocollimator is adjusted to infinity at 546 nm wavelength. Adjustment to other distances or wavelengths is also possible on demand.
- The nomenclature of the autocollimators with CCD-camera mount is as follows:

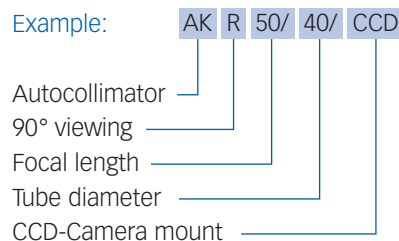

Important:

Please specify collimator reticle (see page 82) as well as illumination (LED-, bulb- or cold light, see page 81) when ordering.

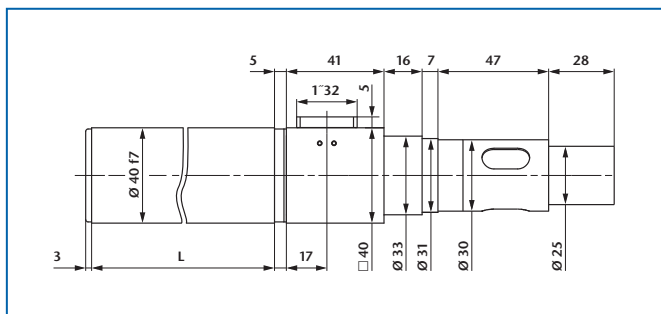

Ord.-No.	Description	Focal length	clear aperture	Meas. range*	L
229 421	AKR 50/40/CCD	50	10	x:4,50° y:3,20°	65
229 422	AKR 90/40/CCD	90	16	x:2,50° y:1,80°	65
229 423	AKR 140/40/CCD	140	28	x:1,60° y:1,20°	118
229 424	AKR 200/40/CCD	200	28	x:1,10° y:0,80°	173
229 425	AKR 300/40/CCD	300	28	x:0,75° y:0,60°	274
229 426	AKR 500/40/CCD	500	28	x:0,45° y:0,30°	474



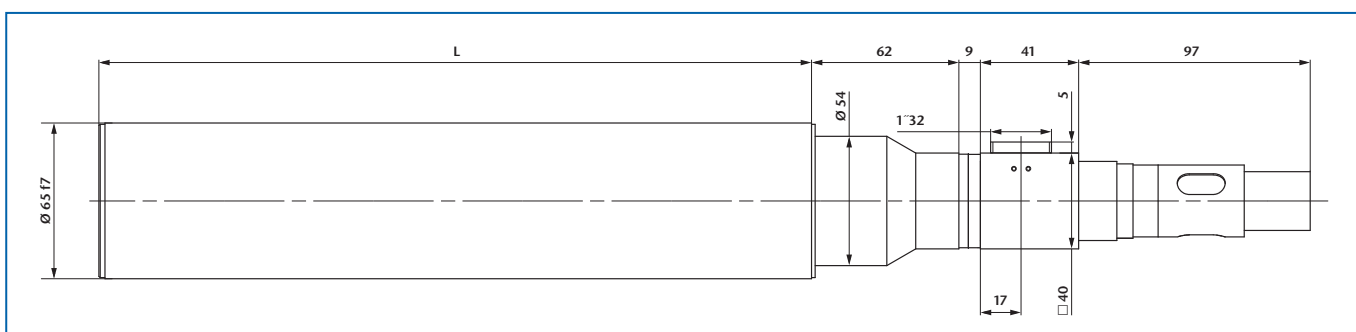
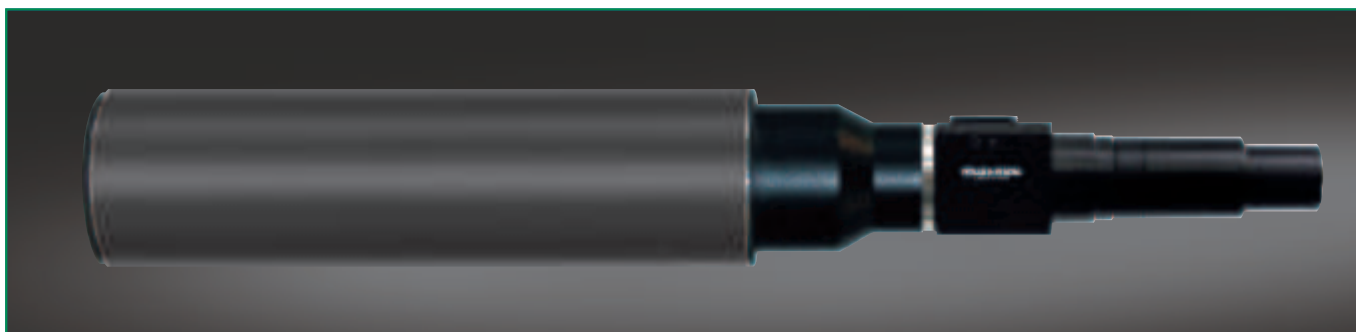

Ord.-No.	Description	Focal length	clear aperture	Meas. range*	L
229 427	AKR 300/65/CCD	300	50	x:0,75° y:0,60°	233
229 428	AKR 500/65/CCD	500	50	x:0,45° y:0,30°	415
229 429	AKR 500T/65/CCD	500	50	x:0,45° y:0,30°	233

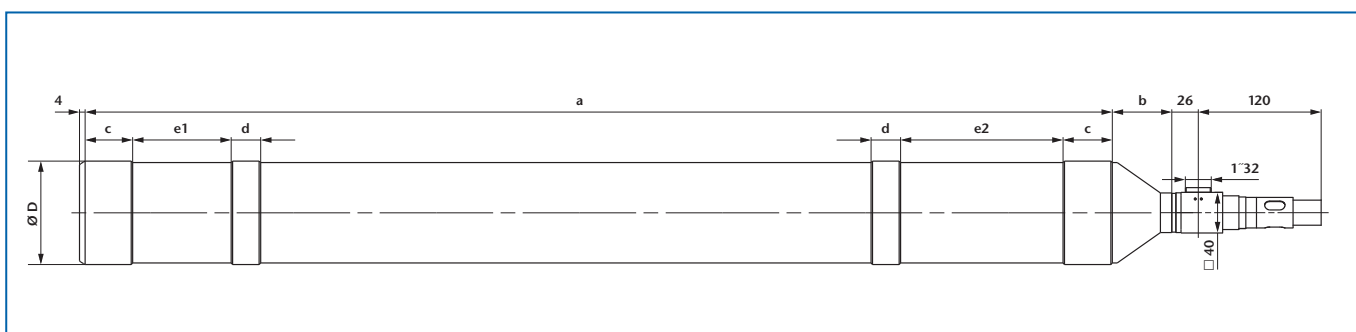

Ord.-No.	Description	Focal length	clear aperture	Meas. range*	D	a	b	c	d	e1	e2
229 432	AKR 600/128/CCD	600	100	x:0,35° y:0,25°	Ø 128 f7	530	46	-	58	154	78
229 433	AKR 1100/105/CCD	1100	78	x:0,20° y:0,15°	Ø 105 f7	1045	66	50	30	165	100

* with 2/3" CCD-Kamera

AUTOCOLLIMATORS

FOCUSABLE – STRAIGHT VIEWING

Description:

For a general description of the principle of functioning of focusable autocollimators see page 43.

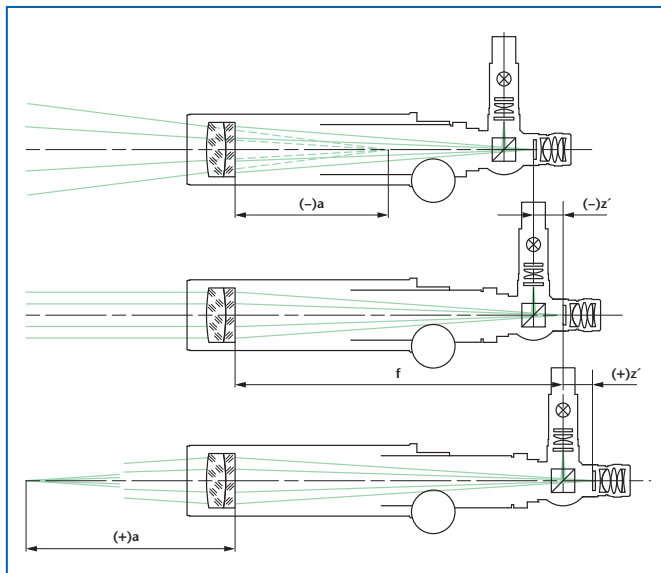

Application areas:

- Measurement of angular tilt
- Qualitative testing of the imaging properties of optical elements and systems
- Measurement of large radii of curvature
- Infinity adjustment to other wavelengths

Notes on ordering:

- Optionally, the autocollimators can be equipped with an eyepiece having 10 mm or 25 mm focal length.
- Two reticles, 6V/5W illumination w/cord, and eyepiece are included.
- The nomenclature of the adjustable autocollimators with straight viewing is as follows:

Example: AK G V 90/ 40/ 14,7 ±6

Autocollimator
 Straight viewing
 Variable
 Focal length
 Tube diameter
 Eyepiece focal length
 Tube extension in mm

Important:

Please specify collimator reticle and eyepiece reticle (see page 82) as well as illumination (LED-, bulb- or cold light, see page 81) when ordering.

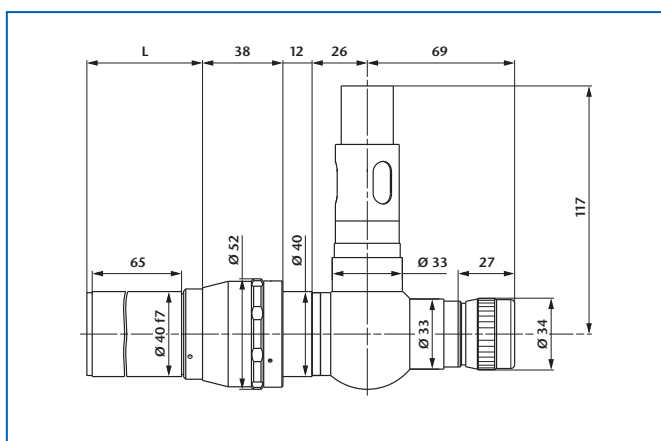

Ord.-No.	Description	Focal length	Free aperture	Tube extension	Meas. range	Distance range	L
229 501	AKGV 90/40/14,7/±6	90	16	±6	3,0°	- ...-1,25 m 1,40 m...+	77±6
229 502	AKGV 90/40/14,7/+12	90	16	+12	3,0°	0,80 m...+	71 ⁺¹²
229 503	AKGV 90/40/14,7/-12	90	16	-12	3,0°	- ...-0,60 m	83 ⁻¹²
229 504	AKGV 140/40/14,7/±6	140	28	±6	2,0°	- ...-3,10 m 3,30 m...+	77±6
229 505	AKGV 140/40/14,7/+12	140	28	+12	2,0°	1,70 m...+	71 ⁺¹²
229 506	AKGV 140/40/14,7/-12	140	28	-12	2,0°	- ...-1,40 m	83 ⁻¹²

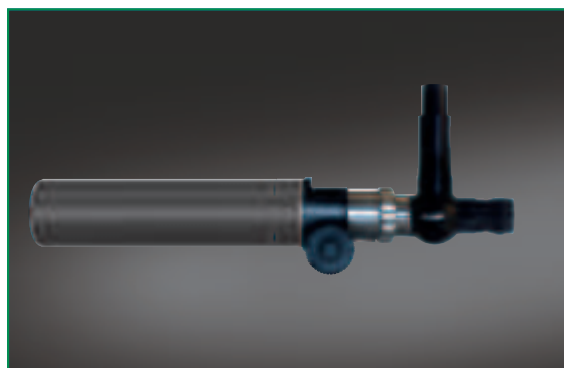
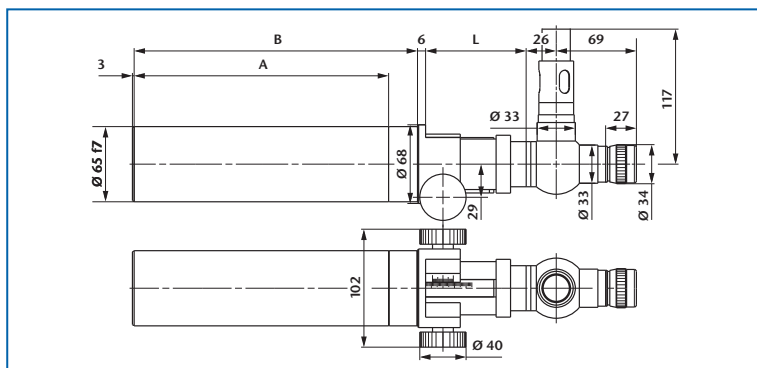

Ord.-No.	Description	Focal length	clear aperture	Tube extension	Meas. range	Distance range	A	B	L
229 507	AKGV 300/65/14,7/±25	300	50	±25	1,0°	- ...-3,4 m 3,8 m...+	220	245	87±25
229 508	AKGV 300/65/14,7/+50	300	50	+50	1,0°	2,1 m...+	220	270	62 ⁺⁵⁰
229 509	AKGV 300/65/14,7/-50	300	50	-50	1,0°	- ...-1,5 m	220	220	112 ⁻⁵⁰
229 510	AKGV 500/65/14,7/±50	500	50	±50	0,5°	- ...-4,5 m 5,4 m...+	310	360	112±50
229 511	AKGV 500/65/14,7/+100	500	50	+100	0,5°	3,0 m...+	310	410	62 ⁺¹⁰⁰
229 512	AKGV 500/65/14,7/-100	500	50	-100	0,5°	- ...-1,5 m	310	310	162 ⁻¹⁰⁰

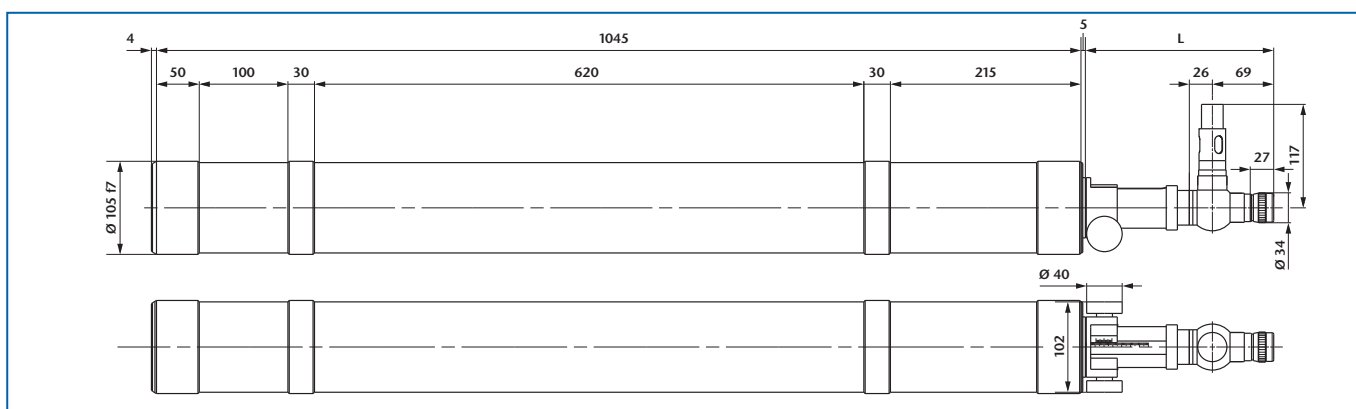
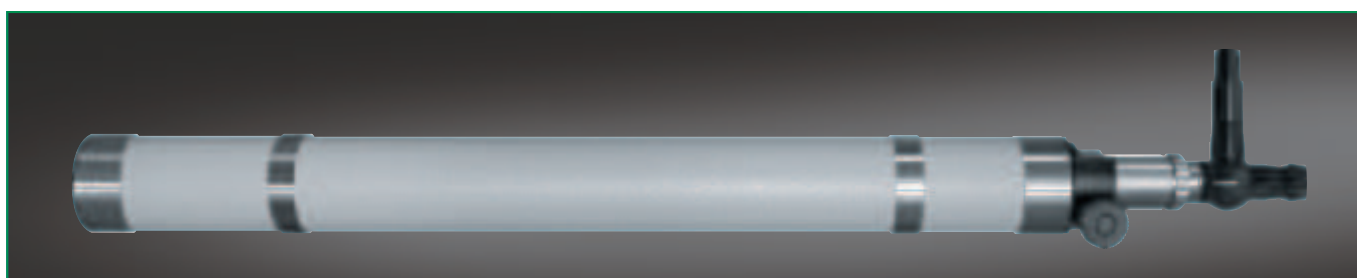

Ord.-No.	Description	Focal length	Free aperture	Tube extension	Meas. range	Distance range	L
229 516	AKGV 1100/105/14,7/±50	1100	78	±50	0,25°	- ...-23,7 m 25,8 m...+	202±50
229 517	AKGV 1100/105/14,7/+100	1100	78	+100	0,25°	13,2 m...+	202 ⁺¹⁰⁰
229 518	AKGV 1100/105/14,7/-100	1100	78	-100	0,25°	- ...-12,0 m	202 ⁻¹⁰⁰

AUTOCOLLIMATORS

FOCUSABLE – 90°-VIEWING

Description:

For a general description of the principle of functioning of focusable autocollimators see page 43.

This autocollimator is equipped with right angle viewing (see page 46).

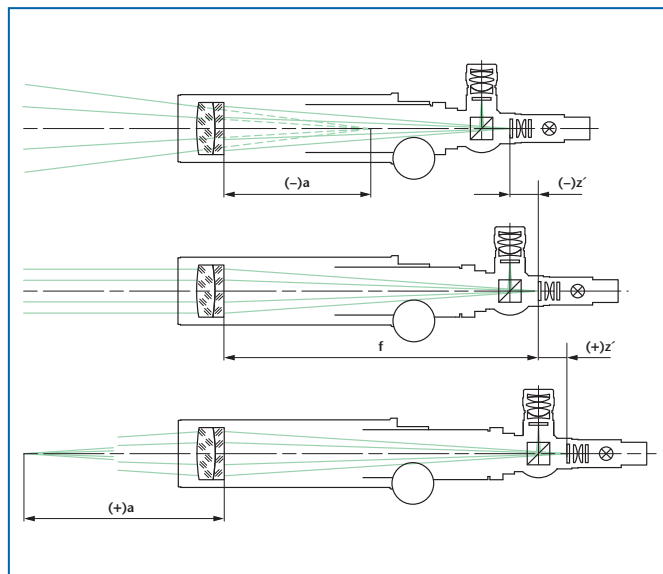

Application areas:

- Adjustment of optical and mechanical systems
- Qualitative testing of the imaging properties of optical elements and systems
- Measurement of large radii of curvature
- Infinity adjustment to other wavelengths

Notes on ordering:

- Optionally, the autocollimators can be equipped with an eyepiece having 10 mm or 25 mm focal length.
- Two reticles, 6V/5W illumination w/cord, and eyepiece are included.
- The nomenclature of the adjustable autocollimators with 90°-viewing is as follows:

Example: AK R V 90/ 40/ 14,7 ±6

Autocollimator — AK
 90° viewing — R
 Variable — V
 Focal length — 90/
 Tube diameter — 40/
 Eyepiece focal length — 14,7
 Tube extension in mm — ±6

Important:

Please specify collimator reticle and eyepiece reticle (see page 82) as well as illumination (LED-, bulb- or cold light, see page 81) when ordering.

Please specify direction of use if reticles with lettering (e.g. coordinate division etc.) are used so that the lettering will be right-side-up.

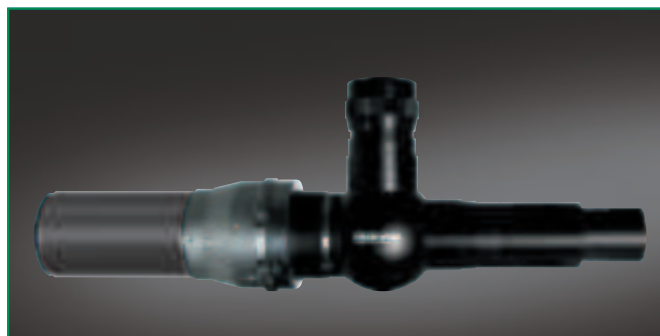
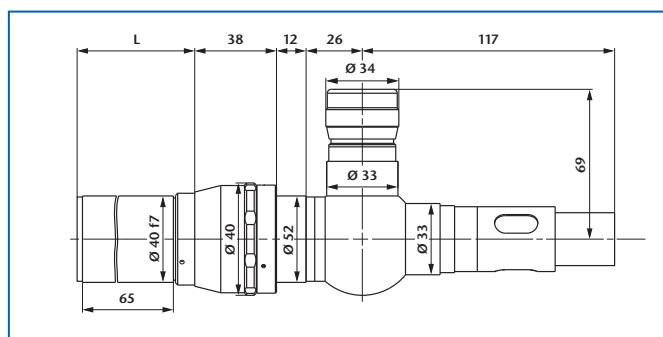

Ord.-No.	Description	Focal length	Free aperture	Tube extension	Meas. range	Distance range	L
229 701	AKRV 90/40/14,7/±6	90	16	±6	3,0°	- ...-1,25 m 1,40 m...+	77±6
229 702	AKRV 90/40/14,7/+12	90	16	+12	3,0°	0,80 m...+	71 ⁺¹²
229 703	AKRV 90/40/14,7/-12	90	16	-12	3,0°	- ...-0,60 m	83 ⁻¹²
229 704	AKRV 140/40/14,7/±6	140	28	±6	2,0°	- ...-3,10 m 3,30 m...+	77±6
229 705	AKRV 140/40/14,7/+12	140	28	+12	2,0°	1,70 m...+	71 ⁺¹²
229 706	AKRV 140/40/14,7/-12	140	28	-12	2,0°	- ...-1,40 m	83 ⁻¹²

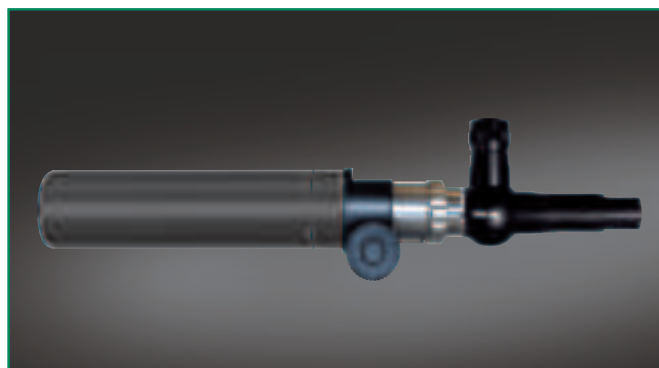
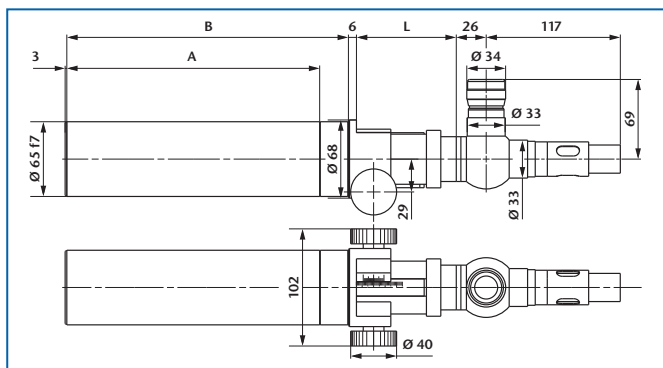

Ord.-No.	Description	Focal length	clear aperture	Tube extension	Meas. range	Distance range	A	B	L
229 707	AKRV 300/65/14,7/±25	300	50	±25	1,0°	- ...-3,4 m 3,8 m...+	220	245	87±25
229 708	AKRV 300/65/14,7/+50	300	50	+50	1,0°	2,1 m...+	220	270	62 ⁺⁵⁰
229 709	AKRV 300/65/14,7/-50	300	50	-50	1,0°	- ...-1,5 m	220	220	112 ⁻⁵⁰
229 710	AKRV 500/65/14,7/±50	500	50	±50	0,5°	- ...-4,5 m 5,4 m...+	310	360	112±50
229 711	AKRV 500/65/14,7/+100	500	50	+100	0,5°	3,0 m...+	310	410	62 ⁺¹⁰⁰
229 712	AKRV 500/65/14,7/-100	500	50	-100	0,5°	- ...-1,5 m	310	310	162 ⁻¹⁰⁰

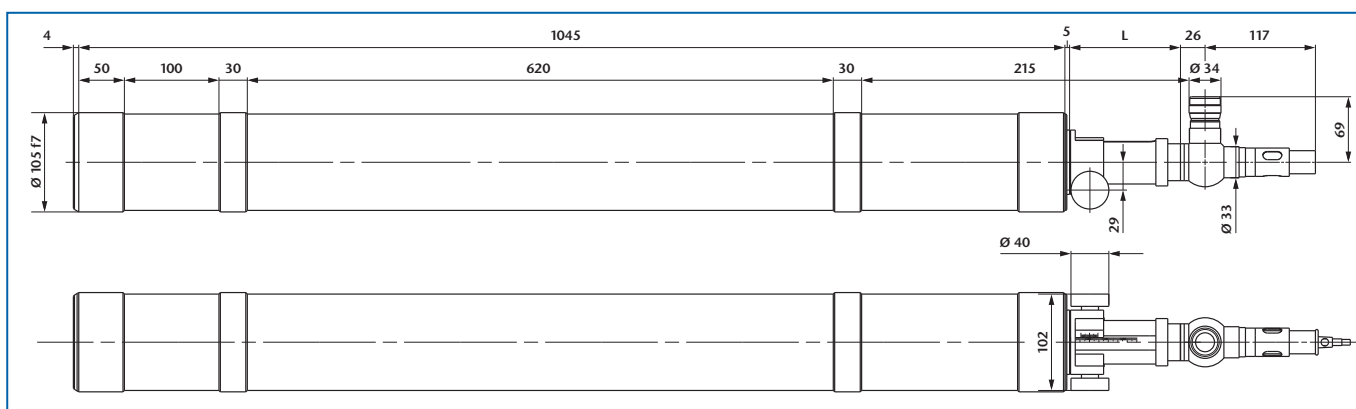
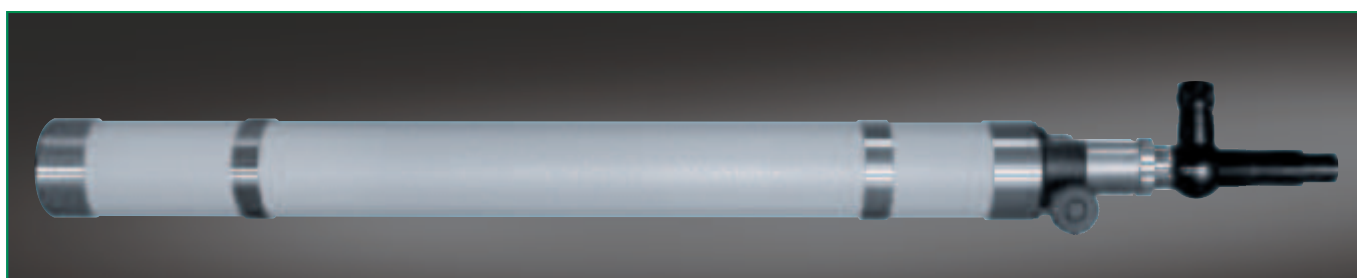

Ord.-No.	Description	Focal length	Free aperture	Tube extension	Meas. range	Distance range	L
229 716	AKRV 1100/105/14,7/±50	1100	78	±50	0,25°	- ...-23,7 m 25,8 m...+	177±50
229 717	AKRV 1100/105/14,7/+100	1100	78	+100	0,25°	13,2 m...+	177 ⁺¹⁰⁰
229 718	AKRV 1100/105/14,7/-100	1100	78	-100	0,25°	- ...-12,0 m	177 ⁻¹⁰⁰

AUTOCOLLIMATORS

FOCUSABLE – STRAIGHT VIEWING WITH DOUBLE MICROMETER

Description:

For a general description of the principle of functioning of focusable autocollimators see page 43.

Additionally, micrometers allow the direct measurement of eyepiece reticle movement. The scale division (SD) of the micrometer drums is 5 μm .

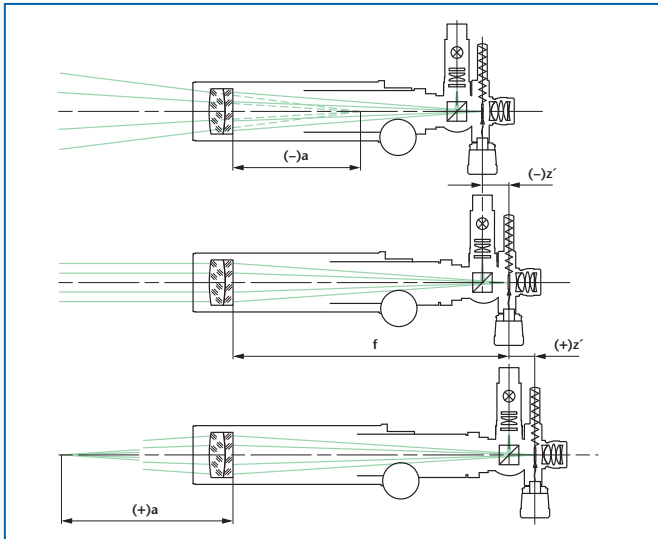

Application areas:

- Measurement of angular tilt
- Qualitative testing of the imaging properties of optical elements and systems
- Measurement of large radii of curvature
- Infinity adjustment to other wavelengths
- Adjustment of optical and mechanical systems

Notes on ordering:

- Optionally, the autocollimators can be equipped with an eyepiece having 10 mm or 25 mm focal length.
- Two reticles, 6V/5W illumination w/cord, and eyepiece are included.
- The nomenclature of the adjustable autocollimators with straight viewing and with double micrometer is as follows:

Example: AK G V 90/ 40/ 14,7 \pm 6 MD

Autocollimator — AK
 Straight viewing — G
 Variable — V
 Focal length — 90
 Tube diameter — 40
 Eyepiece focal length — 14,7
 Tube extension in mm — \pm 6
 Double micrometer — MD

Important:

Please specify collimator reticle and eyepiece reticle (see page 82) as well as illumination (LED-, bulb- or cold light, see page 81) when ordering.

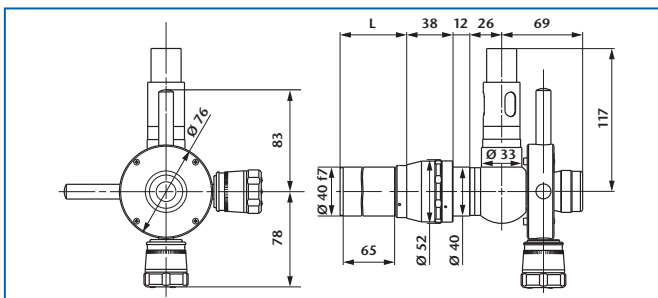

Ord.-No.	Description	Focal length	Free aperture	Tube extension	Meas. range	SD	Distance range	L
229 631	AKGV 90/40/14,7/ \pm 6 MD	90	16	\pm 6	3,0°	5,5"	- ...-1,25 m 1,40 m...+	77 \pm 6
229 632	AKGV 90/40/14,7/+12 MD	90	16	+12	3,0°	5,5"	0,80 m...+	71 ⁺¹²
229 633	AKGV 90/40/14,7/-12 MD	90	16	-12	3,0°	5,5"	- ...-0,60 m	83 ⁻¹²
229 634	AKGV 140/40/14,7/ \pm 6 MD	140	28	\pm 6	2,0°	3,5"	- ...-3,10 m 3,30 m...+	77 \pm 6
229 635	AKGV 140/40/14,7/+12 MD	140	28	+12	2,0°	3,5"	1,70 m...+	71 ⁺¹²
229 636	AKGV 140/40/14,7/-12 MD	140	28	-12	2,0°	3,5"	- ...-1,40 m	83 ⁻¹²

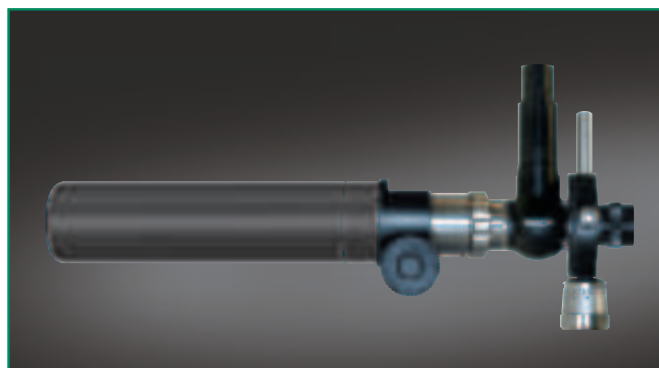
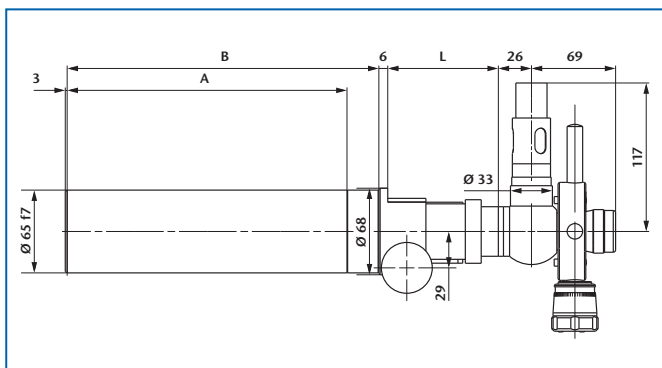

Ord.-No.	Description	Focal length	clear aperture	Tube extension	Meas. range	SD	Distance range	A	B	L
229 640	AKGV 300/65/14,7/±25 MD	300	50	±25	1,0°	2,0"	- ...-3,4 m 3,8 m...+	220	245	220±25
229 638	AKGV 300/65/14,7/+50 MD	300	50	+50	1,0°	2,0"	2,1 m...+	220	270	195 ⁺⁵⁰
229 639	AKGV 300/65/14,7/-50 MD	300	50	-50	1,0°	2,0"	- ...-1,5 m	220	220	245 ⁻⁵⁰
229 641	AKGV 500/65/14,7/±50 MD	500	50	±50	0,5°	1,0"	- ...-4,5 m 5,4 m...+	310	360	245±50
229 644	AKGV 500/65/14,7/+100 MD	500	50	+100	0,5°	1,0"	3,0 m...+	310	410	195 ⁺¹⁰⁰
229 645	AKGV 500/65/14,7/-100 MD	500	50	-100	0,5°	1,0"	- ...-1,5 m	310	310	295 ⁻¹⁰⁰

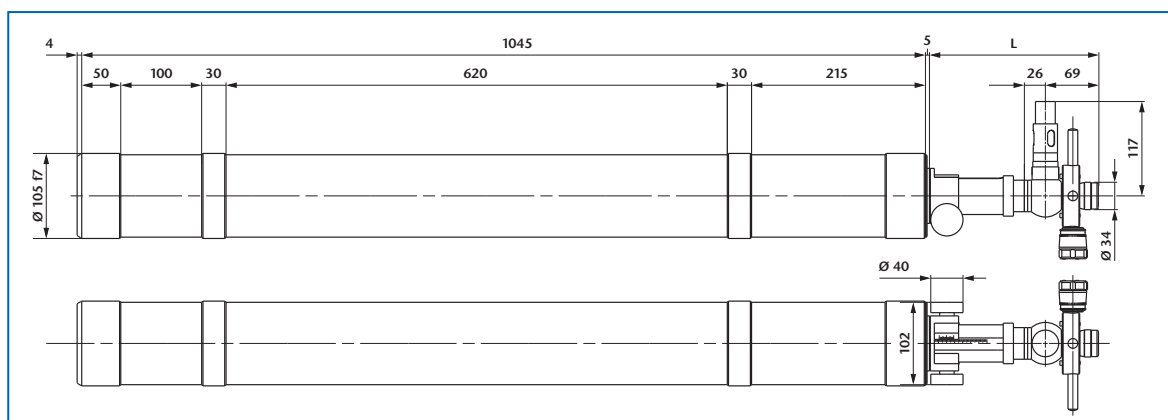
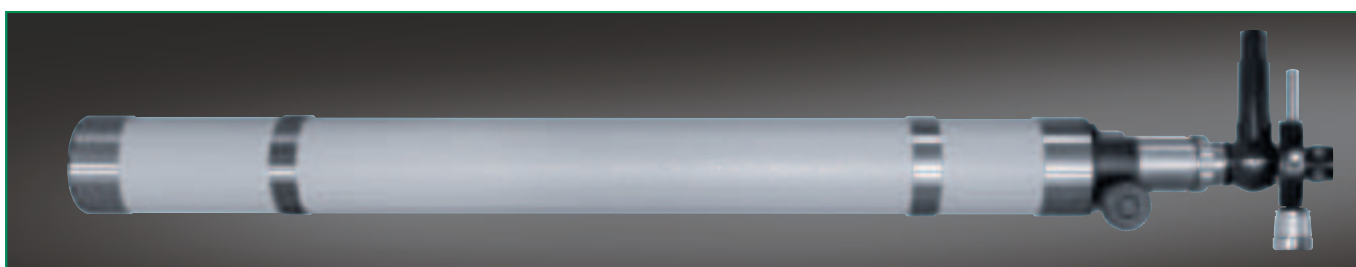

Ord.-No.	Description	Focal length	Free aperture	Tube extension	Meas. range	SD	Distance range	L
229 642	AKGV 1100/105/14,7/±50 MD	1100	78	±50	0,25°	0,5"	- ...-23,70 m 25,80 m...+	202±50
229 646	AKGV 1100/105/14,7/+100 MD	1100	78	+100	0,25°	0,5"	13,20 m...+	202 ⁺¹⁰⁰
229 643	AKGV 1100/105/14,7/-100 MD	1100	78	-100	0,25°	0,5"	- ...-12,00 m	202 ⁻¹⁰⁰

AUTOCOLLIMATORS

FOCUSABLE – STRAIGHT VIEWING WITH DIGITAL DOUBLE MICROMETER

Description:

For a general description of the principle of functioning of focusable autocollimators see page 43.

In place of the micrometer drums above, optionally, programmable digital gauges allow direct reading of the tilting angle in arcsec or mrad.

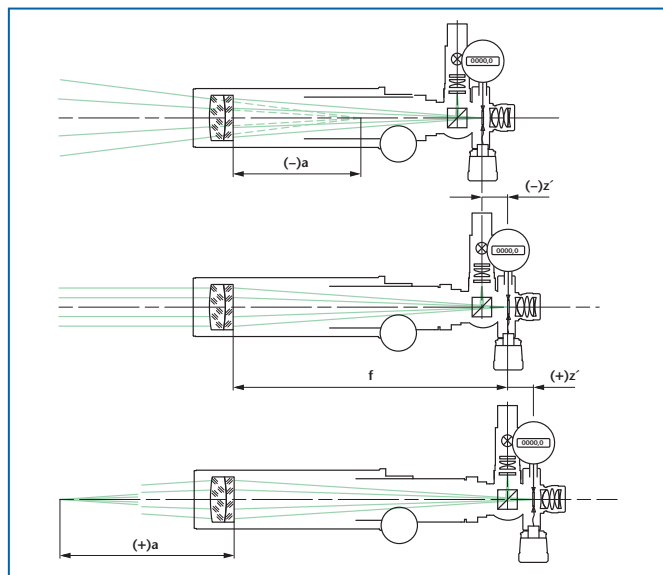

Application areas:

- Measurement of angular tilt
- Adjustment of optical and mechanical systems
- Qualitative testing of the imaging properties of optical elements and systems
- Measurement of large radii of curvature
- Infinity adjustment to other wavelengths

Notes on ordering:

- Optionally, the autocollimators can be equipped with an eyepiece having 10 mm or 25 mm focal length.
- Two reticles, 6V/5W illumination w/cord, and eyepiece are included.
- Specify the unit of display of the digital gauges (mm, arcsec, milliradians).
- The nomenclature of the adjustable autocollimators with digital double micrometer is as follows:

Example: **AK G V 90/ 40/ 14,7 ±6 MDD**

Autocollimator — AK
 Straight viewing — G
 Variable — V
 Focal length — 90
 Tube diameter — 40
 Eyepiece focal length — 14,7
 Tube extension in mm — ±6
 Digital double micrometer — MDD

Important:

Please specify collimator reticle and eyepiece reticle (see page 82) as well as illumination (LED-, bulb- or cold light, see page 81) when ordering.

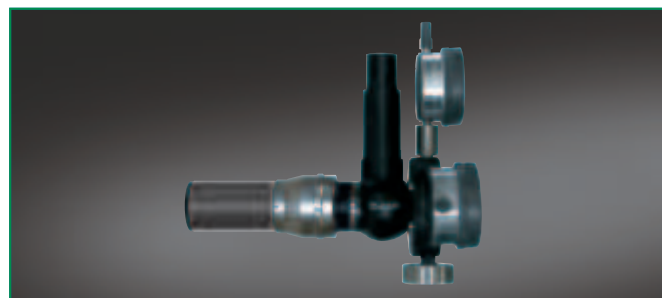
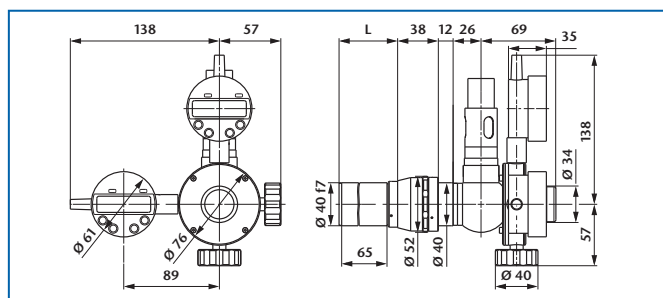

Ord.-No.	Description	Focal length	clear aperture	Tube extension	Meas. range	Resolution	Distance range	L
229 581	AKGV 90/40/14,7/±6 MDD	90	16	±6	3,0°	1,0"	– ...–1,25 m 1,40 m...+	77±6
229 582	AKGV 90/40/14,7/+12 MDD	90	16	+12	3,0°	1,0"	0,80 m...+	71 ⁺¹²
229 583	AKGV 90/40/14,7/–12 MDD	90	16	–12	3,0°	1,0"	– ...–0,60 m	83 ^{–12}
229 584	AKGV 140/40/14,7/±6 MDD	140	28	±6	2,0°	1,0"	– ...–3,10 m 3,30 m...+	77±6
229 585	AKGV 140/40/14,7/+12 MDD	140	28	–12	2,0°	1,0"	1,70 m...+	71 ^{–12}
229 586	AKGV 140/40/14,7/–12 MDD	140	28	–12	2,0°	1,0"	– ...–1,40 m	83 ^{–12}

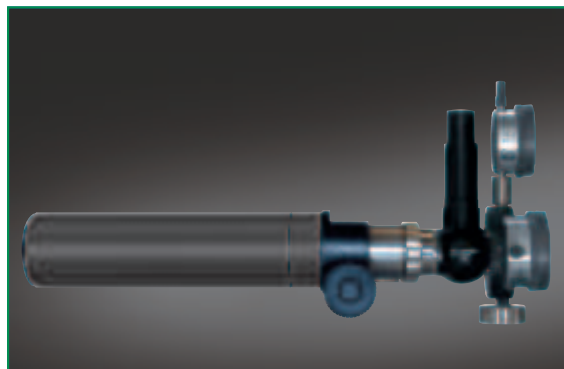
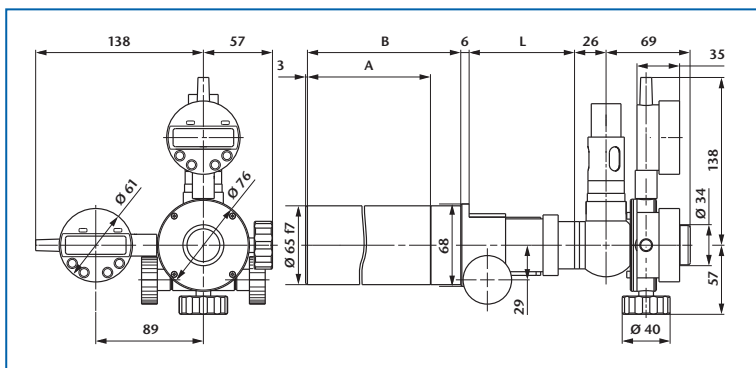

Ord.-No.	Description	Focal length	clear aperture	Tube extension	Meas. range	Resolution	Distance range	A	B	L
229 587	AKGV 300/65/14,7/±25 MDD	300	50	±25	1,0°	0,5 arcsec	- ...-3,4 m 3,8 m...+	220	245	87±25
229 588	AKGV 300/65/14,7/+50 MDD	300	50	+50	1,0°	0,5 arcsec	2,1 m...+	220	270	62 ⁺⁵⁰
229 589	AKGV 300/65/14,7/-50 MDD	300	50	-50	1,0°	0,5 arcsec	- ...-1,5 m	220	220	112 ⁻⁵⁰
229 590	AKGV 500/65/14,7/±50 MDD	500	50	±50	0,5°	0,2 arcsec	- ...-4,5 m 5,4 m...+	310	360	112±50
229 591	AKGV 500/65/14,7/+100 MDD	500	50	+100	0,5°	0,2 arcsec	3,0 m...+	310	410	62 ⁺¹⁰⁰
229 592	AKGV 500/65/14,7/-100 MDD	500	50	-100	0,5°	0,2 arcsec	- ...-1,5 m	310	310	162 ⁻¹⁰⁰

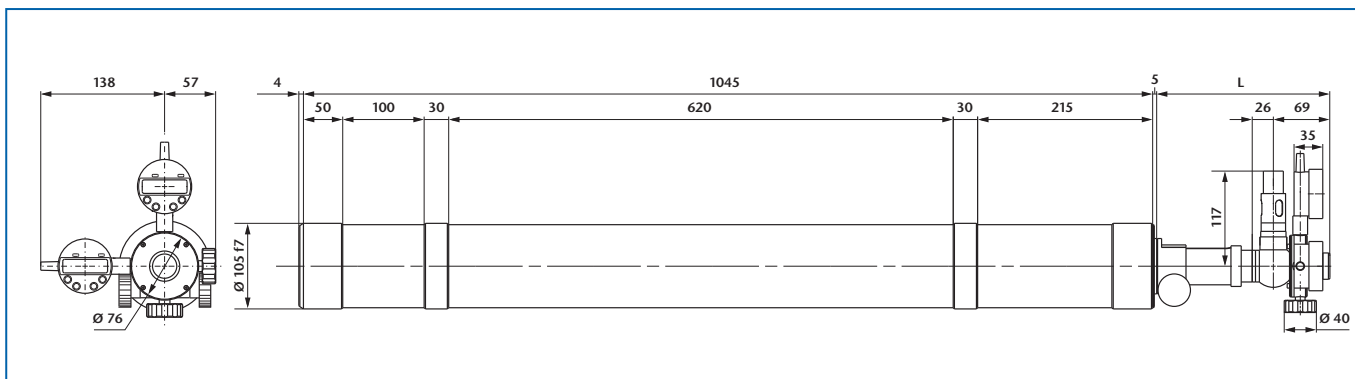
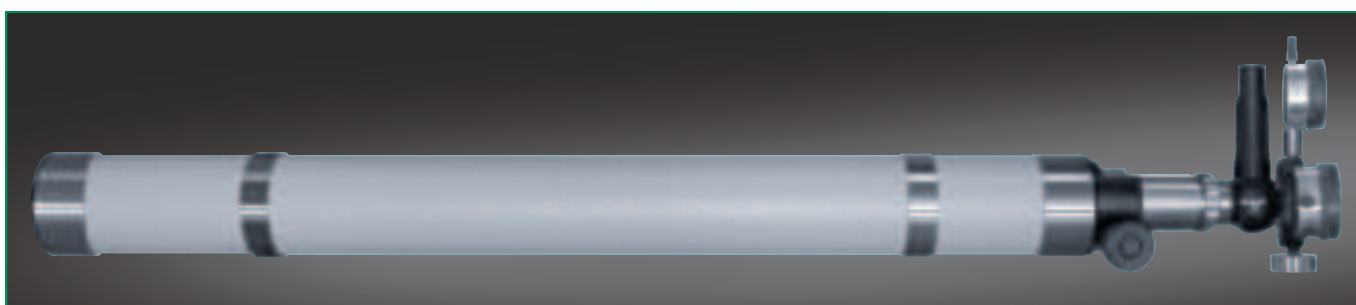

Ord.-No.	Description	Focal length	clear aperture	Tube extension	Meas. range	Resolution	Distance range	L
229 596	AKGV 1100/105/14,7/±50 MDD	1100	78	±50	0,5°	0,1 arcsec	- ...-23,7 m 25,8 m...+	202±50
229 597	AKGV 1100/105/14,7/+100 MDD	1100	78	+100	0,5°	0,1 arcsec	13,2 m...+	202 ⁺¹⁰⁰
229 598	AKGV 1100/105/14,7/-100 MDD	1100	78	-100	0,5°	0,5 arcsec	- ...-12,0 m	202 ⁻¹⁰⁰

AUTOCOLLIMATORS

FOCUSABLE – 90°-VIEWING WITH RETICLE TURRET

Description:

For a general description of the principle of functioning of focusable autocollimators see page 43.

Additionally, the autocollimator provides 6 selectable collimator reticles. The reticle turret allows fast switching between different measuring tasks.

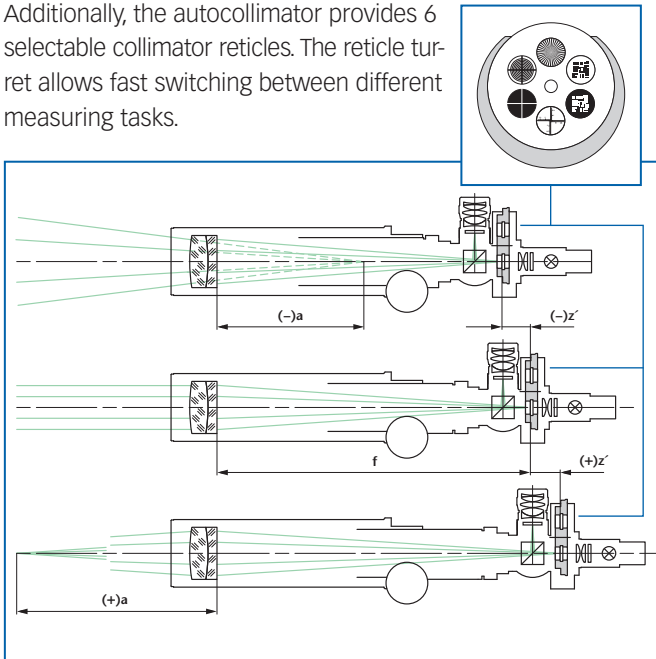

Application areas:

- Adjustment of optical and mechanical systems
- Qualitative testing of the imaging properties of optical elements and systems
- Measurement of large radii of curvature
- Infinity adjustment to other wavelengths

Notes on ordering:

- Optionally, the autocollimators can be equipped with an eyepiece having 10 mm or 25 mm focal length.
- The reticles, 6V/5W illumination w/cord, and eyepiece are included.
- The nomenclature of the adjustable autocollimators with 90°-viewing and with reticle turret is as follows:

Example: AK R V 90/ 40/ 14,7 ±6 SW

Autocollimator
 90° viewing
 Variable
 Focal length
 Tube diameter
 Eyepiece focal length
 Tube extension in mm
 Reticle turret

Important:

Please specify six collimator reticles and one eyepiece reticle (see page 82) as well as illumination (LED-, bulb- or cold light, see page 81) when ordering. Please specify direction of use if reticles with lettering (e.g. coordinate division etc.) are used so that the lettering will be right-side-up.

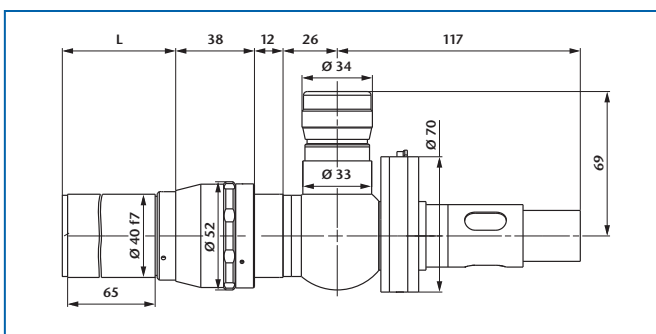

Ord.-No.	Description	Focal length	Free aperture	Tube extension	Meas. range	Distance range	L
229 781	AKRV 90/40/14,7/±6 SW	90	16	±6	3,0°	- ...-1,25 m 1,40 m...+	77±6
229 782	AKRV 90/40/14,7/+12 SW	90	16	+12	3,0°	0,80 m...+	71 ⁺¹²
229 783	AKRV 90/40/14,7/-12 SW	90	16	-12	3,0°	- ...-0,60 m	83 ⁻¹²
229 784	AKRV 140/40/14,7/±6 SW	140	28	±6	2,0°	- ...-3,10 m 3,30 m...+	77±6
229 785	AKRV 140/40/14,7/+12 SW	140	28	+12	2,0°	1,70 m...+	71 ⁺¹²
229 786	AKRV 140/40/14,7/-12 SW	140	28	-12	2,0°	- ...-1,40 m	83 ⁻¹²

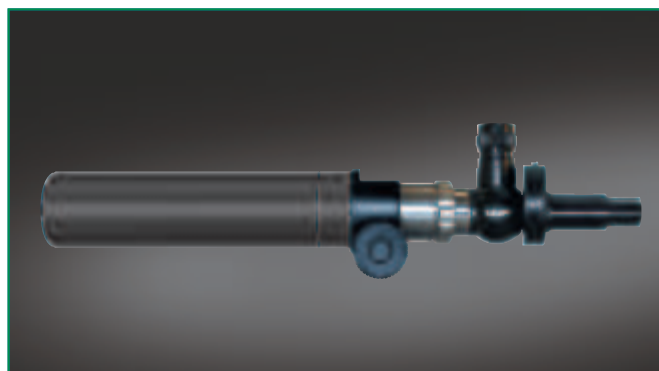
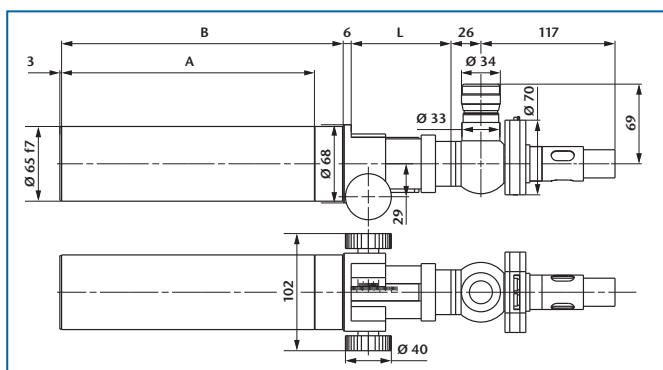

Ord.-No.	Description	Focal length	clear aperture	Tube extension	Meas. range	Distance range	A	B	L
229 787	AKRV 300/65/14,7/±25 SW	300	50	±25	1,0°	- ...-3,4 m 3,8 m...+	220	245	87±25
229 788	AKRV 300/65/14,7/+50 SW	300	50	+50	1,0°	2,1 m...+	220	270	62 ⁺⁵⁰
229 789	AKRV 300/65/14,7/-50 SW	300	50	-50	1,0°	- ...-1,5 m	220	220	112 ⁻⁵⁰
229 790	AKRV 500/65/14,7/±50 SW	500	50	±50	0,5°	- ...-4,5 m 5,4 m...+	310	360	112±50
229 791	AKRV 500/65/14,7/+100 SW	500	50	+100	0,5°	3,0 m...+	310	410	62 ⁺¹⁰⁰
229 792	AKRV 500/65/14,7/-100 SW	500	50	-100	0,5°	- ...-1,5 m	310	310	162 ⁻¹⁰⁰

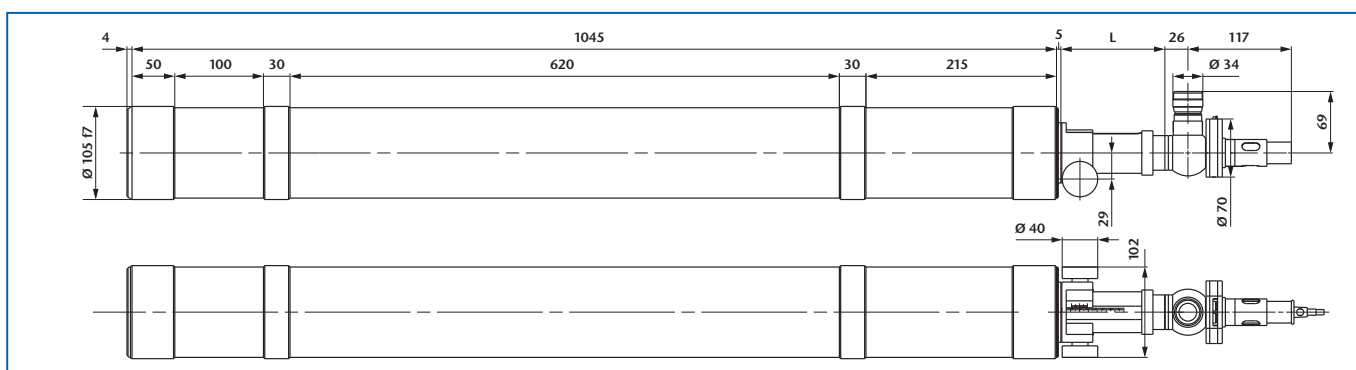
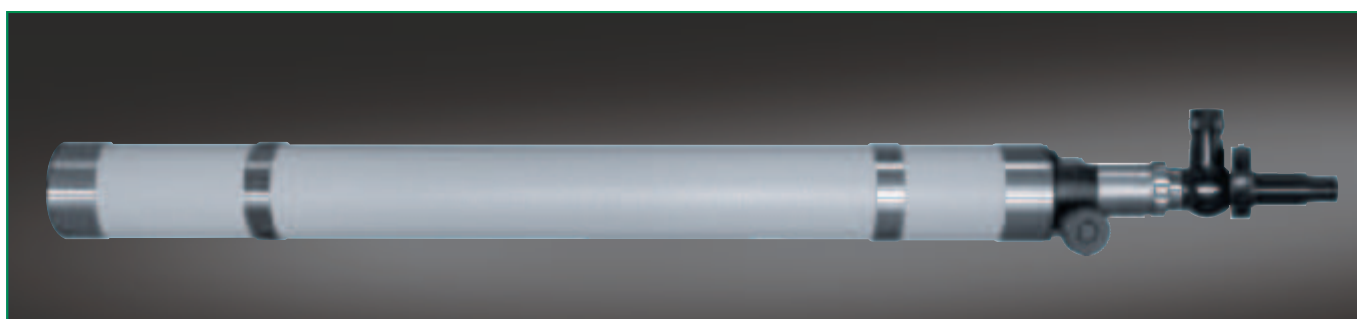

Ord.-No.	Description	Focal length	Free aperture	Tube extension	Meas. range	Distance range	L
229 796	AKRV 1100/105/14,7/±50 SW	1100	78	±50	0,5°	- ...-23,7 m 25,8 m...+	202±50
229 797	AKRV 1100/105/14,7/+100 SW	1100	78	+100	0,5°	13,2 m...+	202 ⁺¹⁰⁰
229 798	AKRV 1100/105/14,7/-100 SW	1100	78	-100	0,5°	- ...-12,0 m	202 ⁻¹⁰⁰

AUTOCOLLIMATORS

FOCUSABLE – WITH CCD-CAMERA MOUNT

Description:

For a general description of the principle of functioning of focusable autocollimators see page 43.

The eyepiece and the eyepiece reticle are replaced by a mount for a C-Mount-CCD-camera and the autocollimation image is directly imaged on the camera chip when it is mounted.

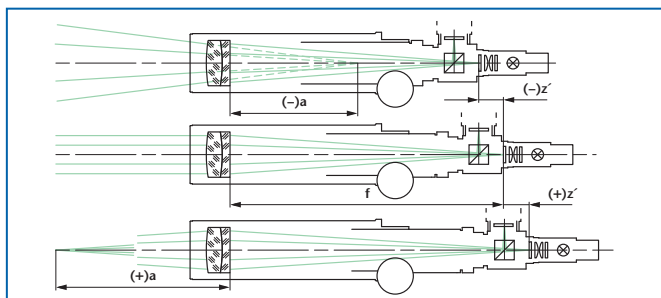

Application areas:

- Adjustment of optical and mechanical systems
- Qualitative testing of the imaging properties of optical elements and systems
- Measurement of large radii of curvature
- Infinity adjustment to other wavelengths

Notes on ordering:

- **The CCD-camera and computer hardware/software are NOT included.**
- As this type of autocollimator does not have an eyepiece reticle a direct measurement of the reticle displacement is impossible. Additional computer with software and frame grabber is needed.

More notes on ordering:

- Collimator reticle and 6V/5W illumination w/cord are included.
- For angular measurement the autocollimator should be equipped with a negative crosshair reticle (see page 83). For testing of imaging quality use resolution target or Siemens Star (see page 87).
- The nomenclature of the adjustable autocollimators with CCD-camera mount is as follows:

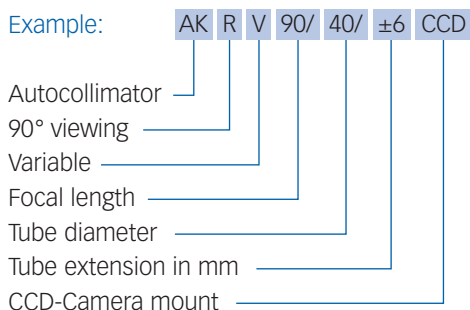

Important:

Please specify collimator reticle (see page 82) as well as illumination (LED-, bulb- or cold light, see page 81) when ordering.

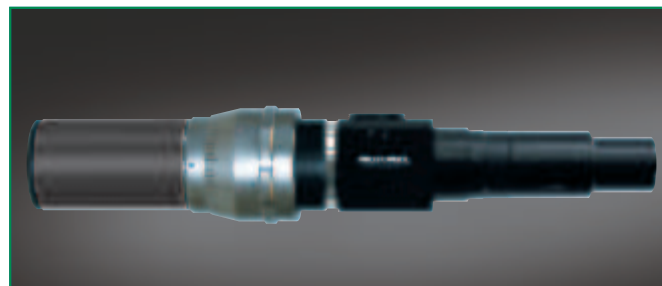
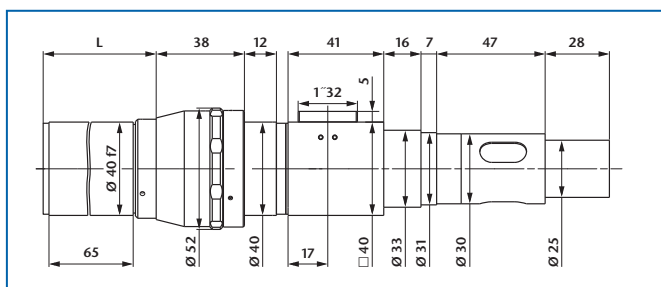

Ord.-No.	Description	Focal length	Free aperture	Tube extension	Meas. range*	Distance range	L
229 471	AKRV 90/40/±6 CCD	90	16	±6	x:2,50° y:1,80°	- ...-1,25 m 1,40 m...+	77±6
229 472	AKRV 90/40/+12 CCD	90	16	+12	x:2,50° y:1,80°	0,80 m...+	71 ⁺¹²
229 473	AKRV 90/40/-12 CCD	90	16	-12	x:2,50° y:1,80°	- ...-0,60 m	83 ⁻¹²
229 474	AKRV 140/40/±6 CCD	140	28	±6	x:1,60° y:1,20°	- ...-3,10 m 3,30 m...+	77±6
229 475	AKRV 140/40/+12 CCD	140	28	+12	x:1,60° y:1,20°	1,70 m...+	71 ⁺¹²
229 476	AKRV 140/40/-12 CCD	140	28	-12	x:1,60° y:1,20°	...-1,40 m	83 ⁻¹²

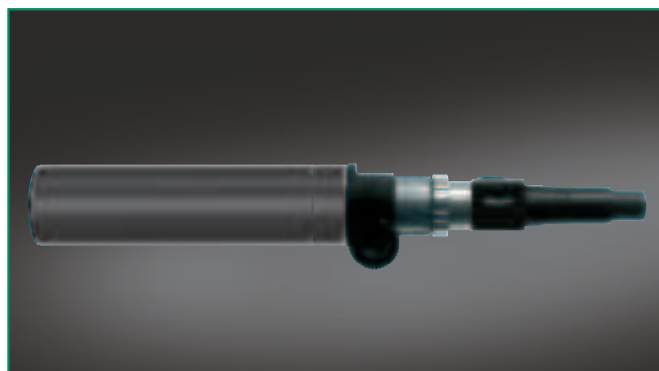
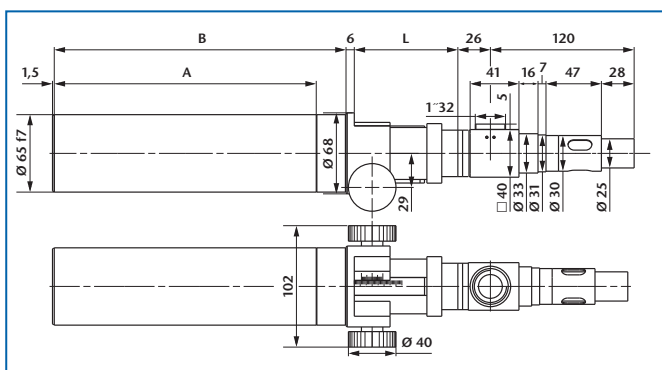

Ord.-No.	Description	Focal length	clear aperture	Tube extension	Meas. range*	Distance range	A	B	L
229 477	AKRV 300/65/±25 CCD	300	50	±25	x:0,75° y:0,60°	- ...-3,4 m 3,8 m...+	220	245	87±25
229 478	AKRV 300/65/+50 CCD	300	50	+50	x:0,75° y:0,60°	2,1 m...+	220	270	62 ⁺⁵⁰
229 479	AKRV 300/65/-50 CCD	300	50	-50	x:0,75° y:0,60°	- ...-1,5 m	220	220	112 ⁻⁵⁰
229 480	AKRV 500/65/±50 CCD	500	50	±50	x:0,45° y:0,30°	- ...-4,5 m 5,4 m...+	310	360	112±50
229 481	AKRV 500/65/+100 CCD	500	50	+100	x:0,45° y:0,30°	3,0 m...+	310	410	62 ⁺¹⁰⁰
229 482	AKRV 500/65/-100 CCD	500	50	-100	x:0,45° y:0,30°	- ...-1,5 m	310	310	162 ⁻¹⁰⁰

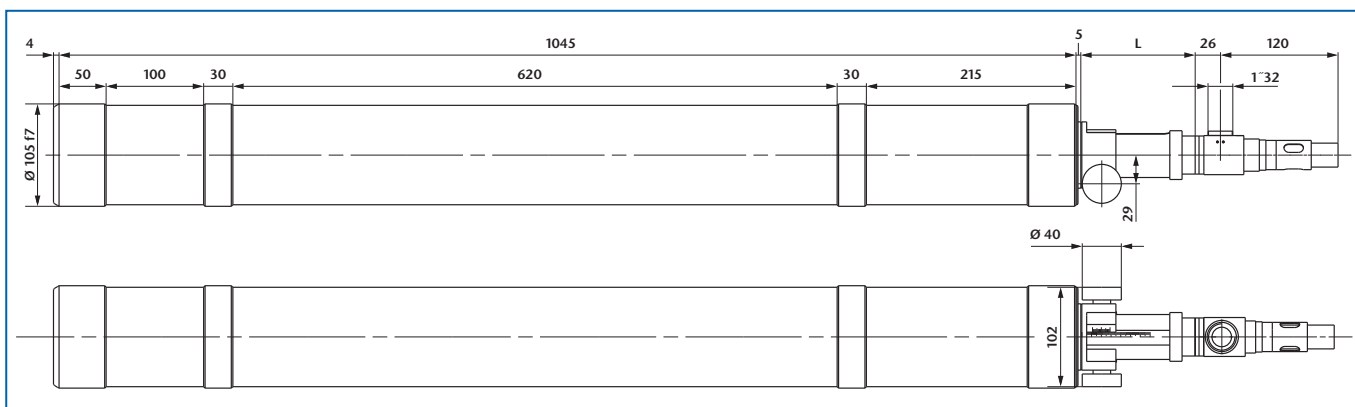

Ord.-No.	Description	Focal length	Free aperture	Tube extension	Meas. range*	Distance range	L
229 486	AKRV 1100/105/±50 CCD	1100	78	±50	x:0,20° y:0,14°	- ...-23,7 m 25,8 m...+	177±50
229 487	AKRV 1100/105/+100 CCD	1100	78	+100	x:0,20° y:0,14°	13,2 m...+	117 ⁺¹²
229 488	AKRV 1100/105/-100 CCD	1100	78	-100	x:0,20° y:0,14°	- ...-12,0 m	117 ⁻¹²

* mit 2/3" CCD-Kamera

MODULAR COMPONENTS

INTRODUCTION

Modular components

Autocollimators, collimators and testing telescopes by MÖLLER-WEDEL OPTICAL are of modular design, the components are freely interchangeable and, of course, precisely matched to each other. Free interchangeability allows manifold combination possibilities and ensures economic solution of problems. The basic component is the objective tube which is available in great variety of different focal lengths

and tube diameters. Eyepieces, adapter sleeves with reticle and illuminator or autocollimation eyepieces, can also be attached. So one can combine modules to make a telescope, a collimator or even an autocollimator. Minimum effort is needed for setting up different combinations as the basic components are the same in any configuration.

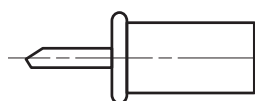

Light source

For operation of collimators and autocollimators a light source is necessary.

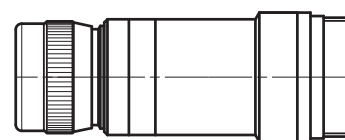

Reticle sleeve with eyepiece

Reticle adapter sleeve with reticle and eyepiece forms with an objective tube a testing telescope.

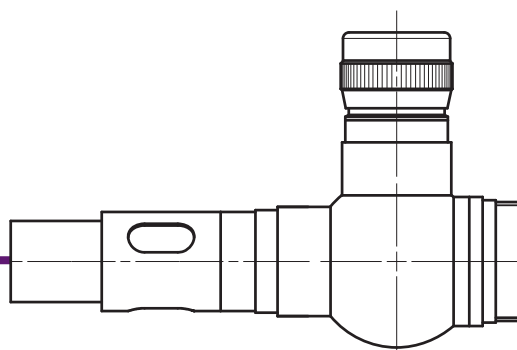

Autocollimation eyepiece

The autocollimation eyepiece with illumination and eyepiece forms with an objective tube an autocollimator.

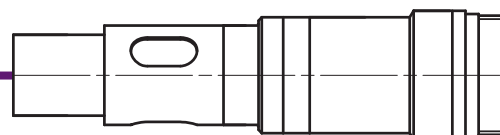

Reticle sleeve with illumination

Reticle adapter sleeve with illumination forms with an objective tube a collimator.

Supplementary extension to other measurement tasks could not be simpler. All modular components are available separately. The user is free to set up the components as she or he wishes. Due to the way they work, collimators and telescopes require one reticle, autocollimators require two.

Objectiv tube

Objective tubes are the core components of all testing telescopes, collimators and autocollimators. The cylindrical tube is hard chromed for high wear-resistance. All objective tubes of a standard design are fitted with two-element objectives (achromats). By interchanging the objective tube (alteration of the focal length) the measuring range and the accuracy is altered.

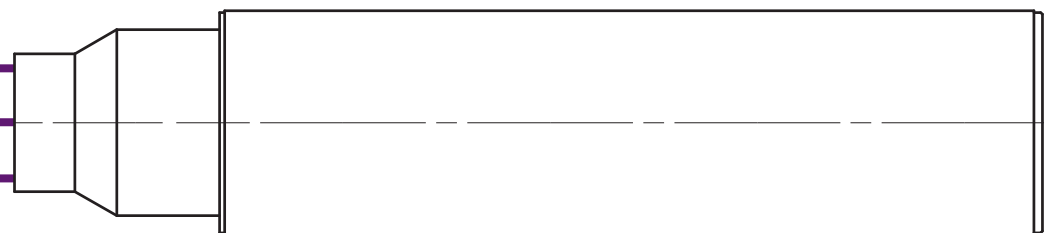

Objective tubes are available either with fixed distance settings or with variable focus adjustment. The variable focus adjustment is realized by tube extension. Focusable objective tubes are used where discrete distances have to be focused or if the collimators/telescopes/autocollimators should be used at other wave-lengths than 546 nm.

MODULAR COMPONENTS

OBJECTIVE TUBES

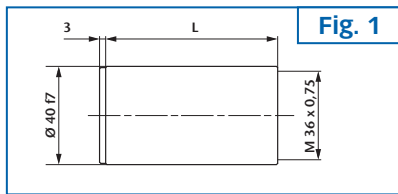

Fig. 1

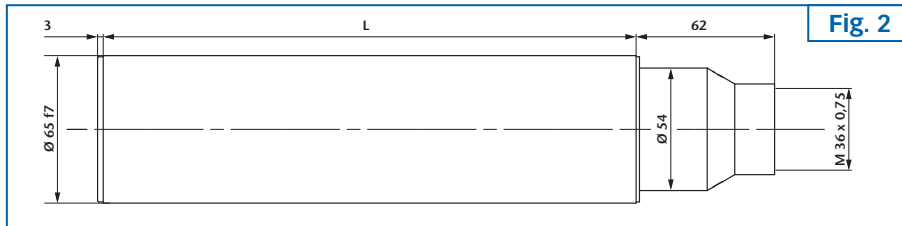

Fig. 2

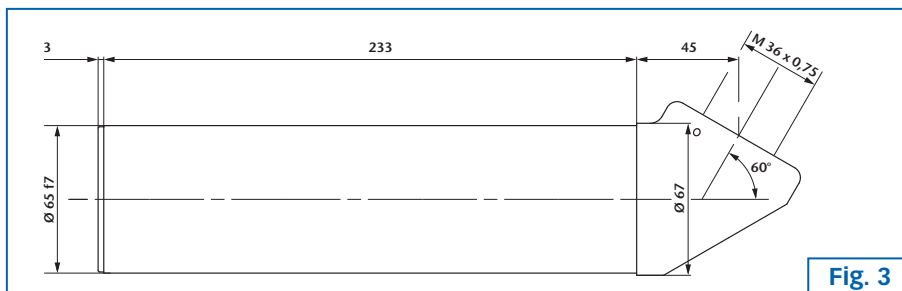

Fig. 3

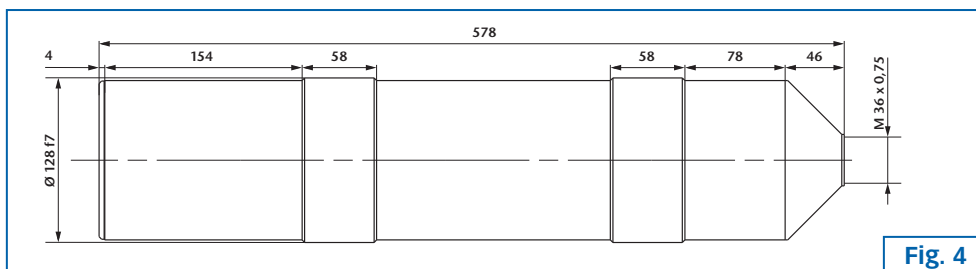

Fig. 4

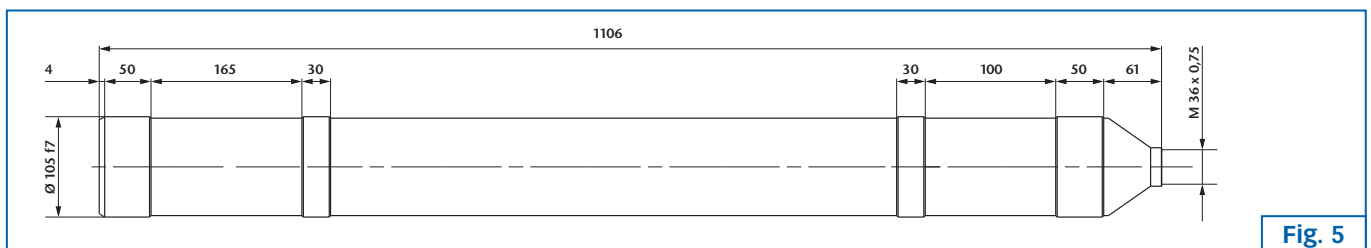

Fig. 5

Ord.-No.	Description	Focal length	clear aperture	L	Fig.
211 210	Objective tube 90/40	90	16	65	1
211 220	Objective tube 140/40	140	28	118	1
211 230	Objective tube 200/40	200	28	173	1
211 240	Objective tube 300/40	300	28	274	1
211 250	Objective tube 500/40	500	28	474	1
211 301	Objective tube 300/65	300	50	233	2
211 310	Objective tube 500/65	500	50	415	2
211 330	Objective tube 500T/65	500	50	233	2
211 526	Objective tube 500T/65W	500	50	–	3
211 347	Objective tube 600/128	600	100	–	4
211 401	Objective tube 1100/105	1100	78	–	5

MODULAR COMPONENTS

OBJECTIVE TUBES WITH TUBE EXTENSION

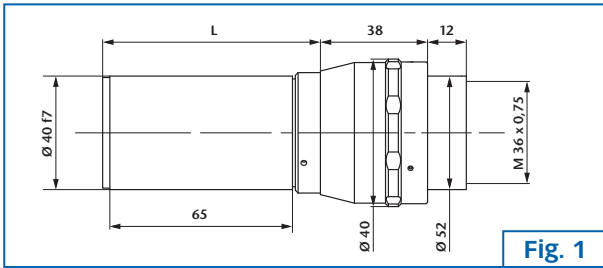

Fig. 1

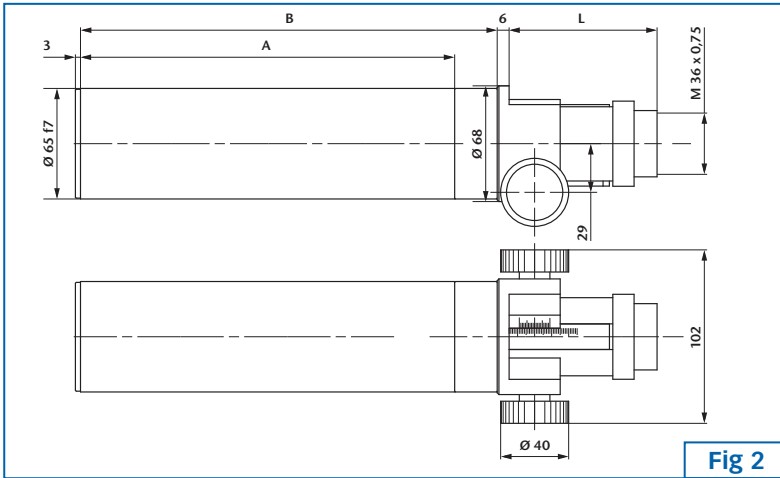

Fig 2

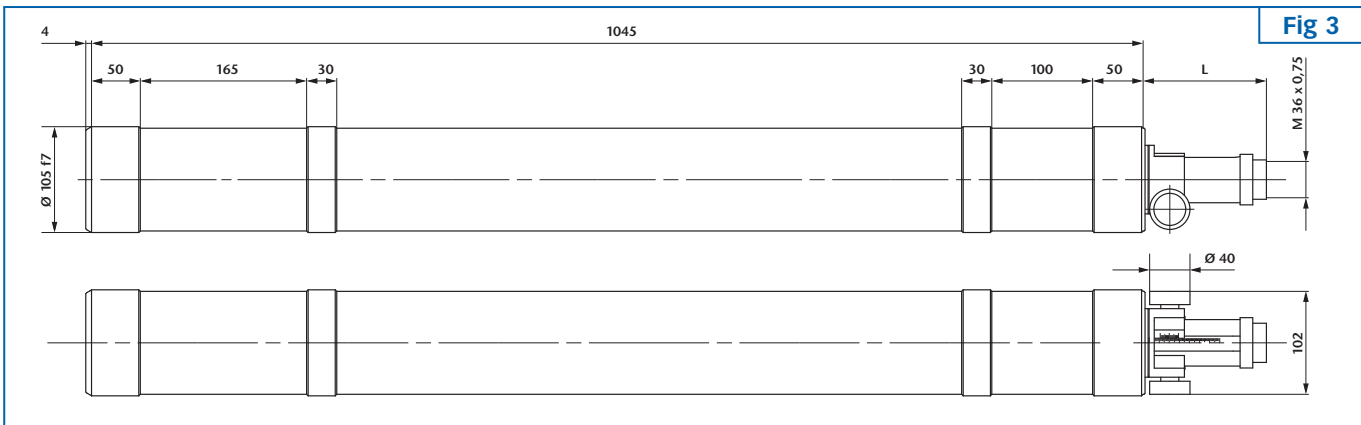
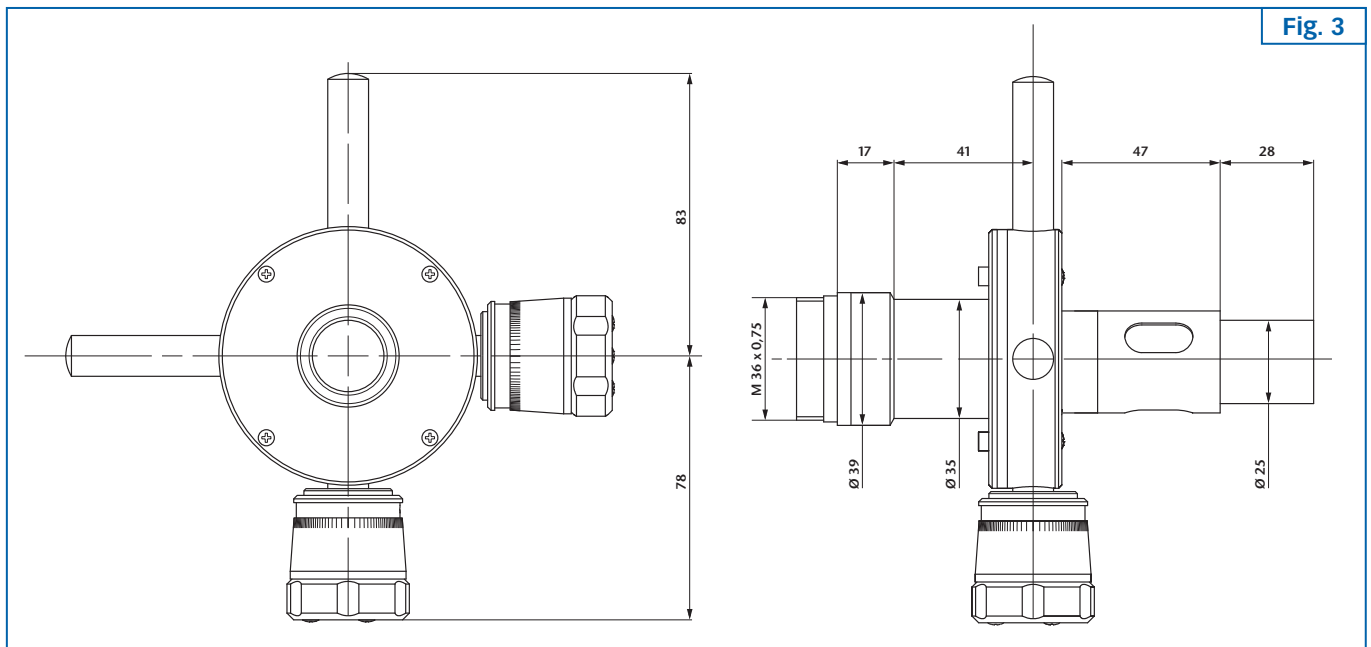
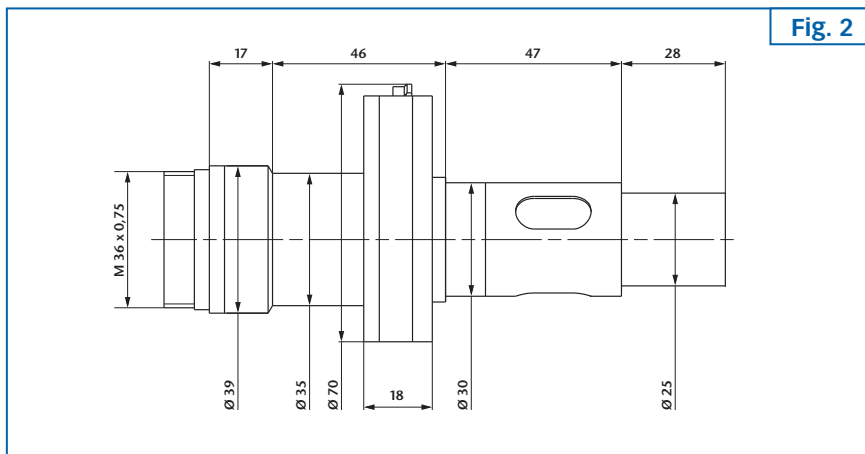
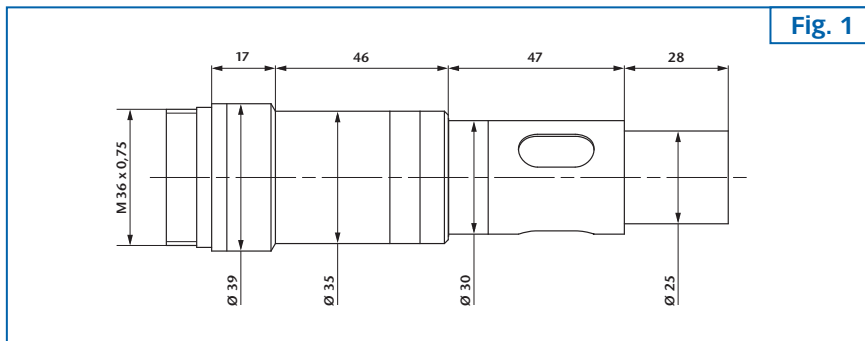

Fig 3

Ord.-No.	Description	Focal length	clear aperture	Tube extension	L	A	B	Fig.
213 101	Objective tube 90/40 ±6	90	16	±6	77±6	-	-	1
213 102	Objective tube 90/40 +12	90	16	+12	71 ⁺¹²	-	-	1
213 103	Objective tube 90/40 -12	90	16	-12	83 ⁻¹²	-	-	1
213 104	Objective tube 140/40 ±6	140	28	±6	77±6	-	-	1
213 105	Objective tube 140/40 +12	140	28	+12	71 ⁺¹²	-	-	1
213 106	Objective tube 140/40 -12	140	28	-12	83 ⁻¹²	-	-	1
213 301	Objective tube 300/65 ±25	300	50	±25	84±25	220	245	2
213 302	Objective tube 300/65 +50	300	50	+50	59 ⁺⁵⁰	220	270	2
213 303	Objective tube 300/65 -50	300	50	-50	109 ⁻⁵⁰	220	220	2
213 304	Objective tube 500/65 ±50	500	50	±50	109±50	310	360	2
213 305	Objective tube 500/65 +100	500	50	+100	59 ⁺¹⁰⁰	310	410	2
213 306	Objective tube 500/65 -100	500	50	-100	159 ⁻¹⁰⁰	310	310	2
213 316	Objective tube 1100/105 ±50	1100	78	±50	212±50	-	-	3
213 317	Objective tube 1100/105 +100	1100	78	+100	212 ⁺¹⁰⁰	-	-	3
213 318	Objective tube 1100/105 -100	1100	78	-100	212 ⁻¹⁰⁰	-	-	3

MODULAR COMPONENTS

RETICLE SLEEVE WITH ILLUMINATION



Ord.-No.	Description	Fig.
215 002	Sleeve with reticle illumination	1
215 023	Sleeve with reticle turret illumination	2
215 042	Sleeve with double micrometer illumination	3

Notes on ordering:

Please specify reticle(s) (see page 82) and illumination (see page 81) when ordering.



MODULAR COMPONENTS

RETICLE SLEEVES WITH EYEPIECE

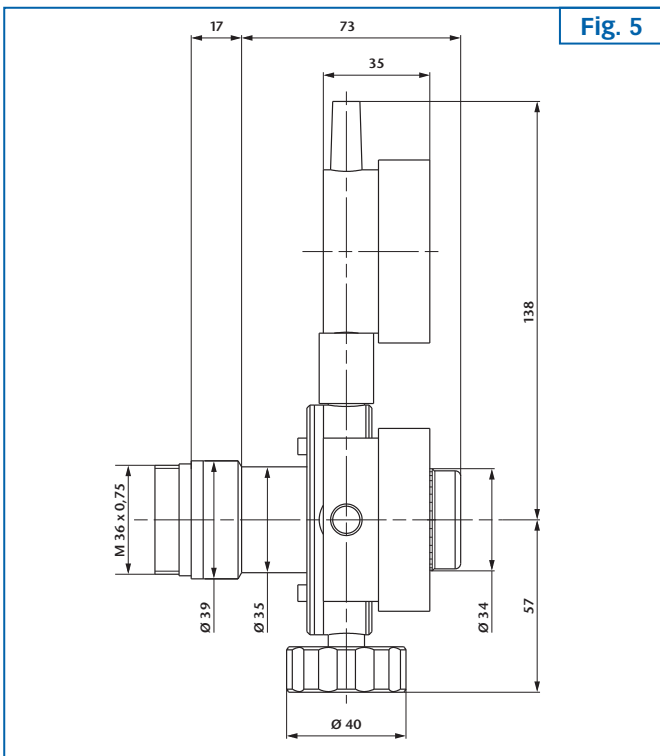
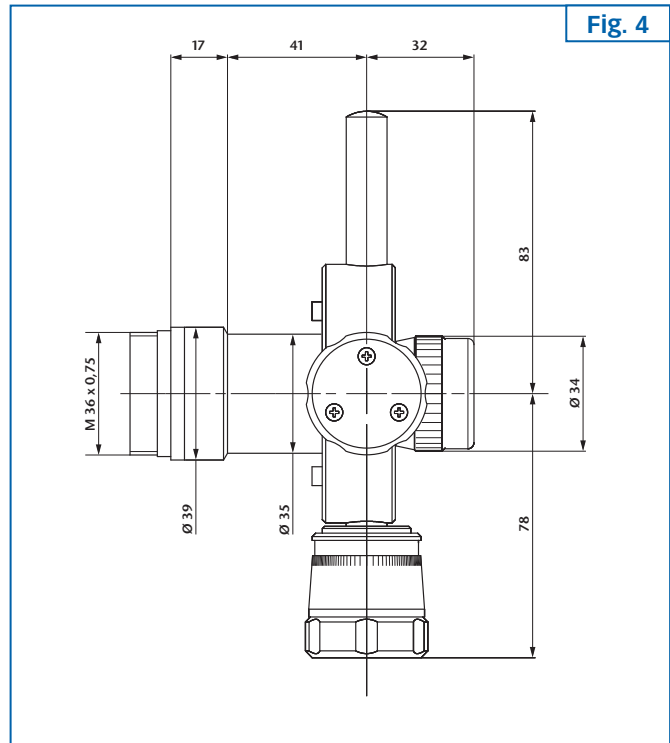
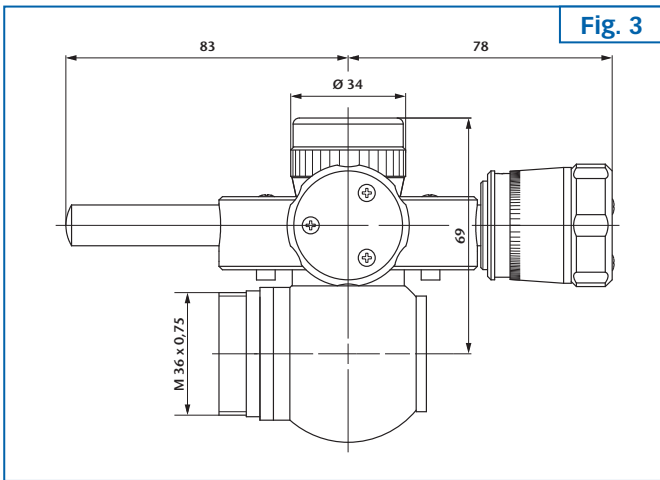
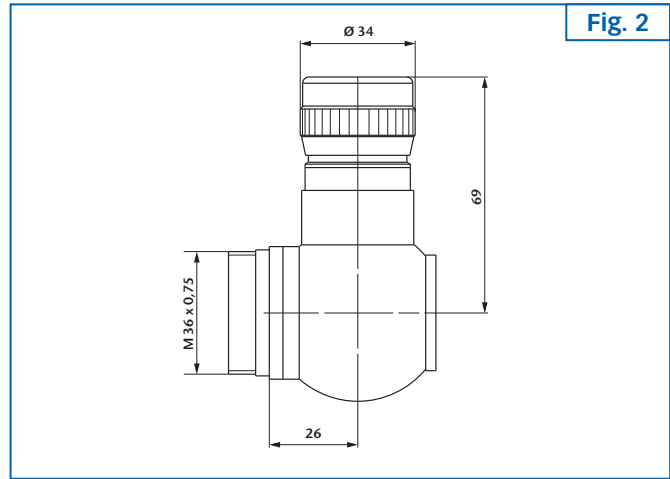
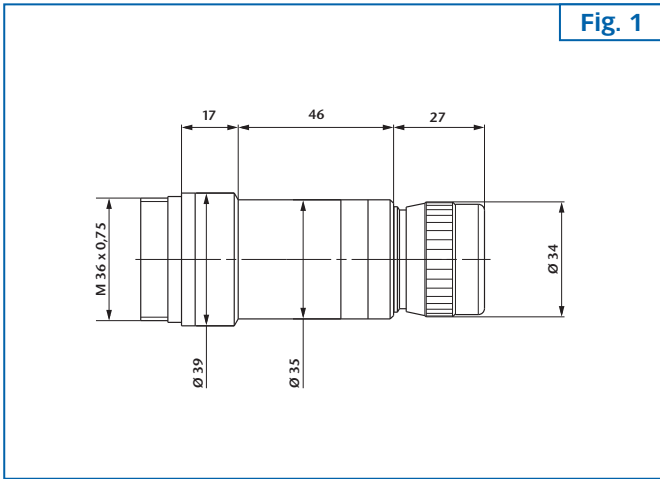

Notes on ordering:

Instead of eyepiece f=14,7 mm eyepieces with f=10 mm and f=25 mm can be used.

Ord.-No.	Description	Fig.
215 002	Sleeve with reticle	1
217 015	Eyepiece f= 14,7	
211 545	90°-sleeve with reticle	2
217 015	Eyepiece f= 14,7	
215 053	90°-sleeve with double micrometer	3
217 015	Eyepiece f= 14,7	
215 042	Sleeve with double micrometer	4
217 015	Eyepiece f= 14,7	
215 051	Sleeve with digital double micrometer	5
217 015	Eyepiece f= 14,7	

MODULAR COMPONENTS

AUTOCOLLIMATION EYEPIECES

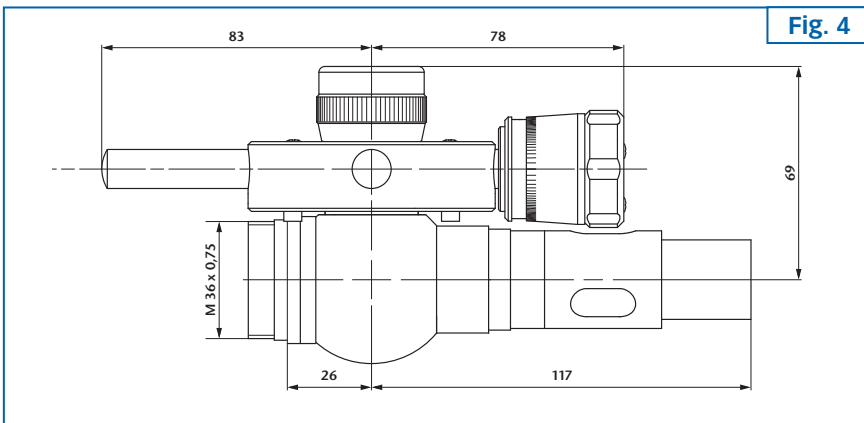
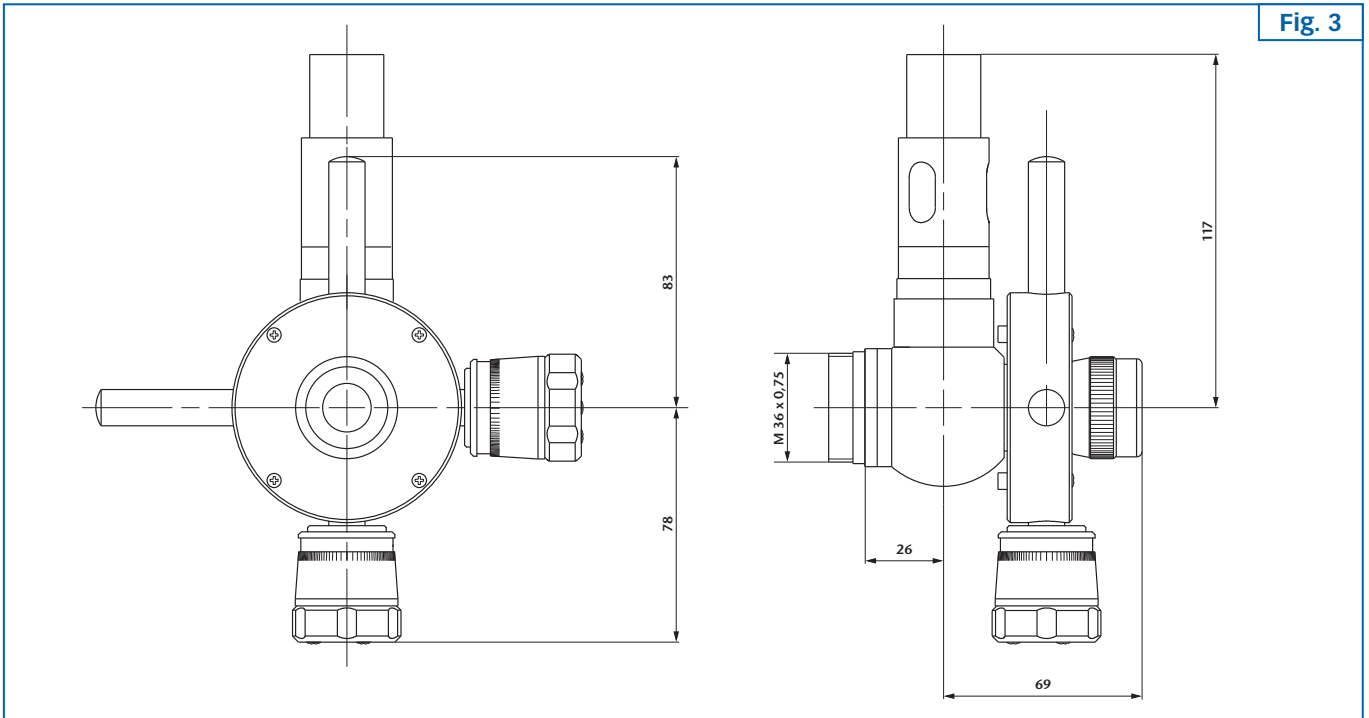
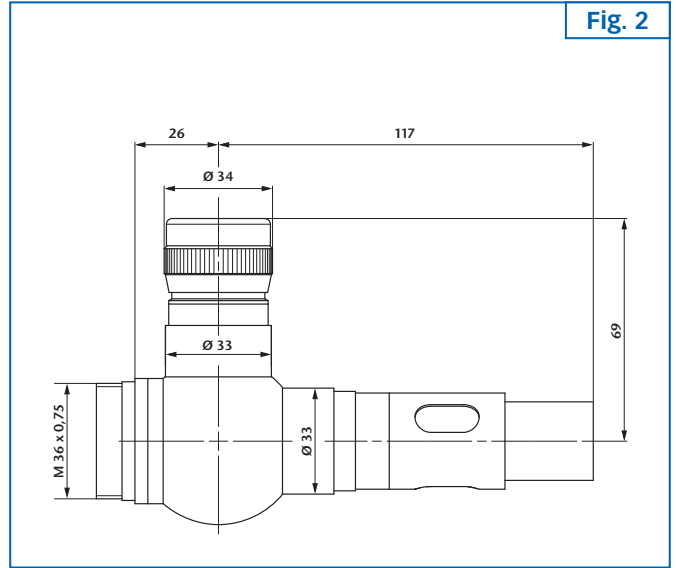
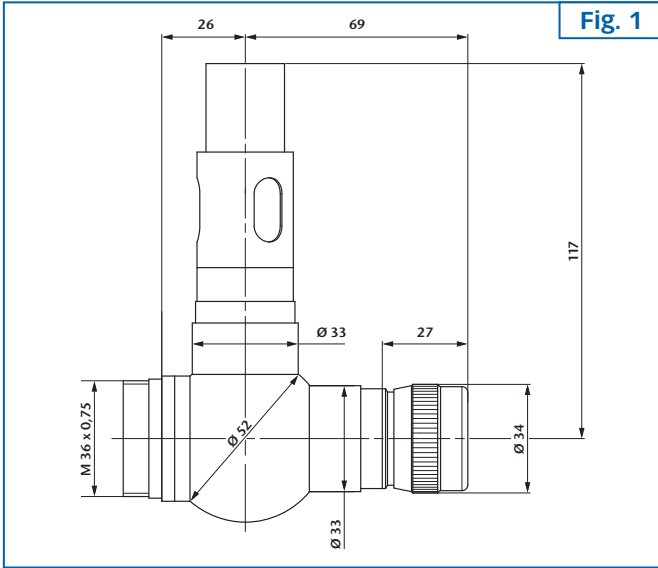

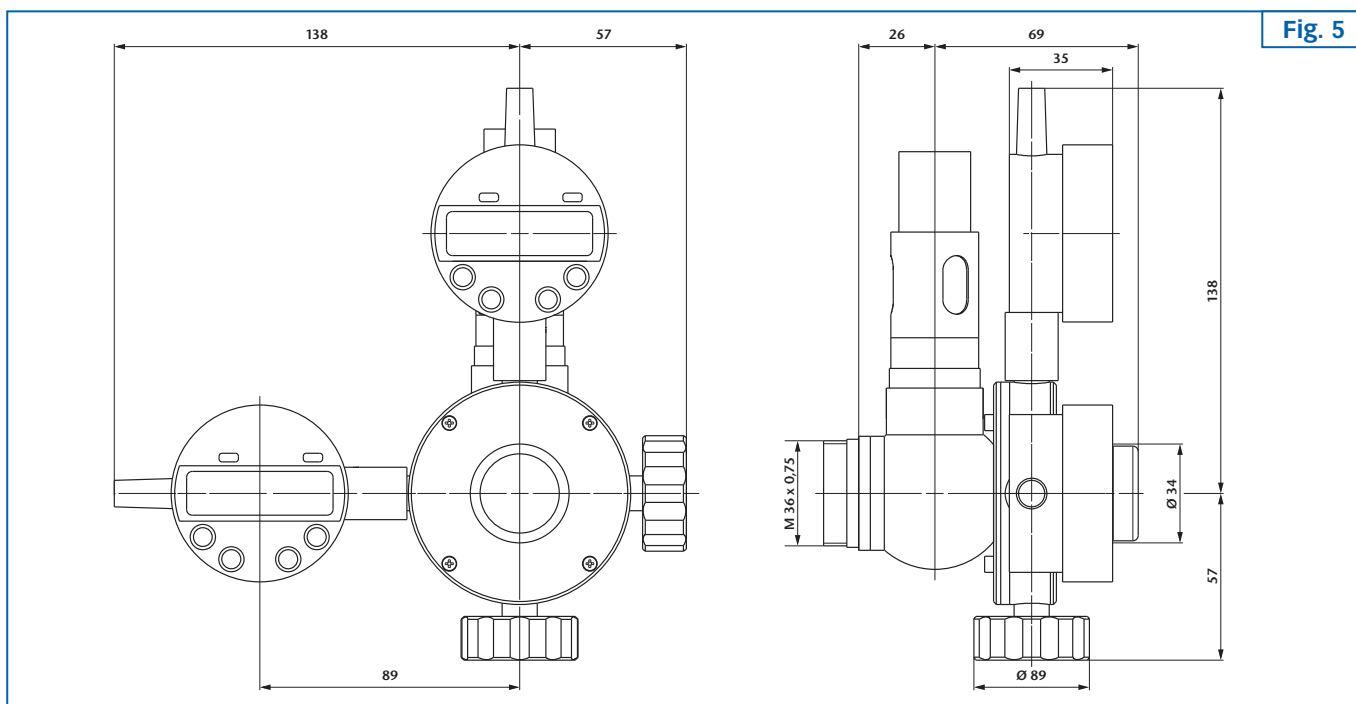

Fig. 5

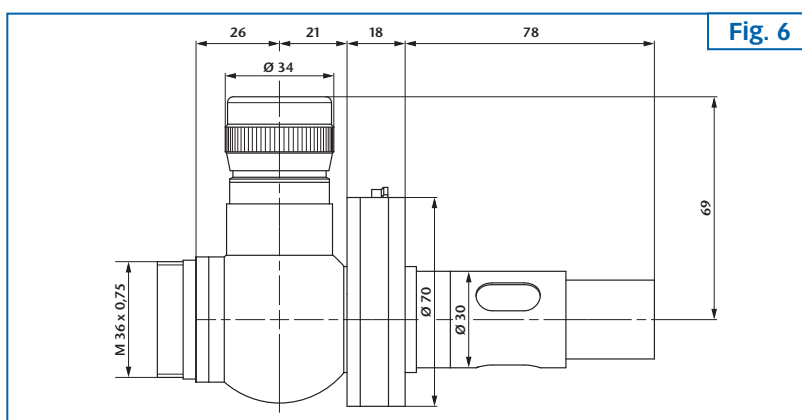

Fig. 6

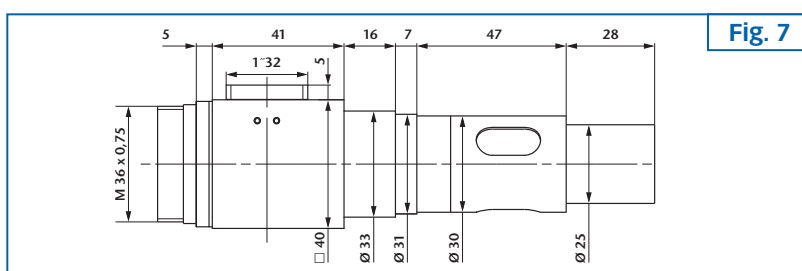

Fig. 7

Notes on ordering:

As standard all autocollimation eyepieces are fitted with illumination 6V/5W.

Optionally, the autocollimation eyepieces can be equipped with an eyepiece $f=10$ mm or $f=25$ mm.

Specify reticles (see page 82) and illumination (see page 81) when ordering.

Ord.-No.	Description	Fig.
219 101	AKG-eyepiece/physical beam splitting/straight viewing/eyepiece $f=14,7$ mm	1
219 035	AKG-eyepiece/geometrical beam splitting/straight viewing/eyepiece $f=14,7$ mm	1
219 120	AKR-eyepiece/physical beam splitting/90°- viewing/eyepiece $f=14,7$ mm	2
219 112	AKG-eyepiece/physical beam splitting/straight viewing/double micrometer/eyepiece $f=14,7$ mm	3
219 125	AKR-eyepiece/physical beam splitting/90°- viewing/double micrometer/eyepiece $f=14,7$ mm	4
219 113	AKG-eyepiece/physical beam splitting/straight viewing/digital double micrometer/eyepiece $f=14,7$ mm	5
219 122	AKR-eyepiece/physical beam splitting/90°- viewing/reticle turret/eyepiece $f=14,7$ mm	6
219 115	AKR-eyepiece/physical beam splitting/90°- viewing/for direct mounting of a CCD-camera with C-Mount	7

MODULAR COMPONENTS

EYEPIECES

Description:

The magnification of an autocollimator or telescope can be changed by changing the eyepieces.

The magnification V of a telescope is determined by the relation of objective focal length f_{ob} to eyepiece focal length f_{ok} :

$$V = \frac{f_{ob}}{f_{ok}}$$

Models:

Three different eyepieces are available: with $f=10$ mm, $f=14,7$ mm and $f=25$ mm.

After removing the eyepiece cover ring eyepiece $f=14,7$ mm and $f=25$ mm can be upgraded with a C-mount-camera adapter to connect a CCD-camera to the eyepiece.

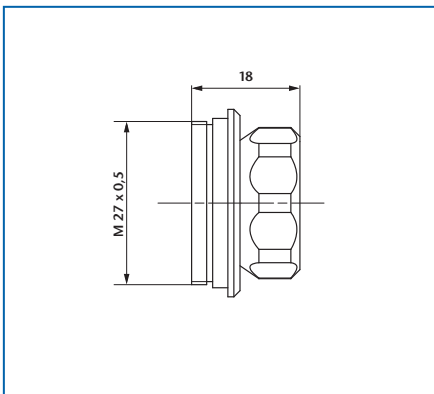

EYEPIECE $f=10$ mm

Application:

- Magnified observation of the reticle image at reduced FOV
- **Magnification 25x**

Ord.-No.	Description
217 010	Eyeiece $f=10$ M 27x0,5

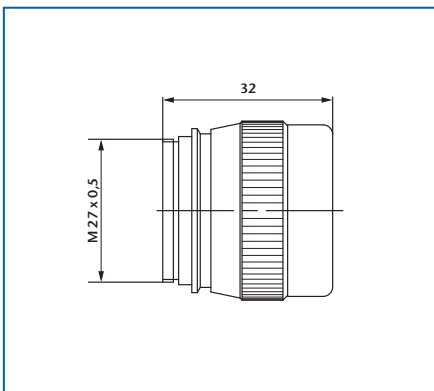

EYEPIECE $f=14,7$ mm

Application:

- Standard measuring tasks
- Mount of a C-Mount-Adapter
- **Magnification 17x**

Ord.-No.	Description
217 015	Eyeiece $f=14,7$ M 27x0,5

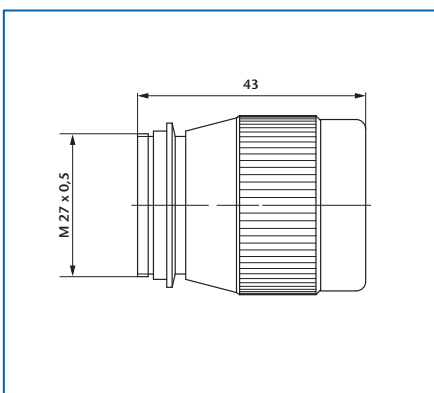

EYEPIECE $f=25$ mm

Application:

- Mount of a C-Mount-Adapter (in connection with $\frac{1}{2}$ " CCD-camera) for larger FOV
- **Magnification 10x**

Ord.-No.	Description
217 025	Eyeiece $f=25$ M 27x0,5

MODULAR COMPONENTS

ILLUMINATION

TRANSFORMER

Power supply (must be ordered separately) for bulb illumination 6V/5W of collimators and autocollimators.

Ord.-No.	Description
568 101	Transformer 230V/3,5...6 V AC
568 102	Transformer 115V/3,5...6 V AC



LED-ILLUMINATION

High-efficient-LED-Illumination for visual collimators and auto-collimators. This type of illumination is working besides with normal power supply also with accumulators that can be inserted into the control unit of the illumination.

The LED-illumination has the following advantages:

- rather unlimited lifetime of LED's
- excellent brightness; can be controlled continuously
- can be used with rechargeable batteries
- 2 auto-/collimators can be operated with one control unit



Ord.-No.	Description	Wavelength
217 321	Illumination green, 1-arm	525 nm
217 322	Illumination red, 1-arm	660 nm
217 323	Illumination blue, 1-arm	465 nm
217 324	Illumination white, 1-arm	-

Ord.-No.	Description	Wavelength
217 325	Illumination green, 2-arms	525 nm
217 326	Illumination red, 2-arms	660 nm
217 327	Illumination blue, 2-arms	465 nm
217 328	Illumination white, 2-arms	-

LIGHT CONDUCTIVE FIBER ILLUMINATION

Light conductive fiber illuminations (with cold light source) are first choice for applications that require higher brightness, for example for measurement of small prism.

Ord.-No.	Description	Fig.
217 333	Light conductive fiber illum. 20W/230V	A
217 334	Light conductive fiber illum. 20W/115V	A
217 331	Light conductive fiber illum. 150W/230V	B
217 332	Light conductive fiber illum. 150W/115V	B
217 336	Light conductive fiber illum. 150W/115V 2-arms	-

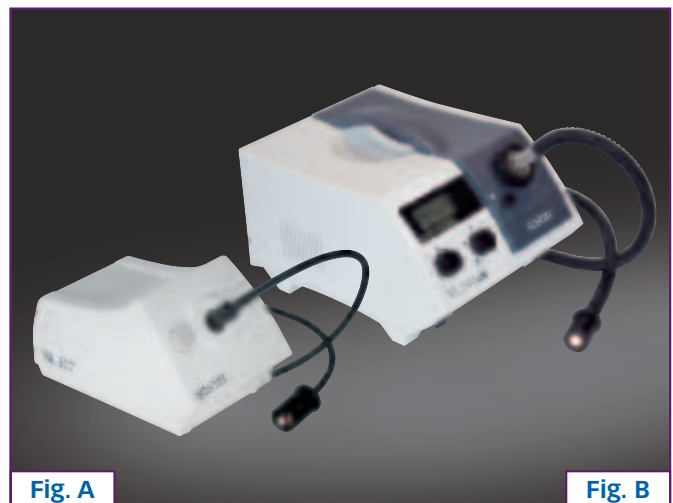

Fig. A

Fig. B

RETICLES

INTRODUCTION

Reticles:

Reticles are a part of collimators, testing telescopes and autocollimators. All reticles have a diameter of 12 mm and a thickness of 1 mm. The clear aperture of a reticle used at the illuminated side of an autocollimator is 6 mm and at the eyepiece side 10 mm. The clear aperture of reticles used in collimators and telescopes is 10 mm.

General selection criteria:

- For focal lengths more than 300 mm or extensive stopping down (for example when using mirrors with small diameter) reticles with bigger line thickness are recommended.
- When using autocollimators or testing telescopes with 90°-viewing and reticles with lettering (e.g. coordinate division etc.) please specify the direction of use (see figure A, B, C, D)

Figure A:
Vertical use down-
wards looking

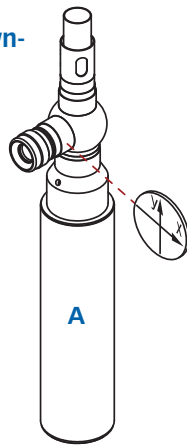

Figure B:
Vertical use up-
wards looking

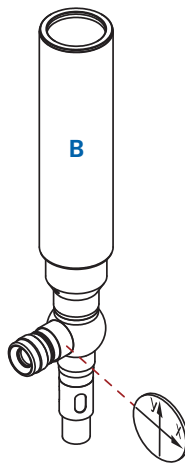

Figure C:
Horizontal use
from left to right

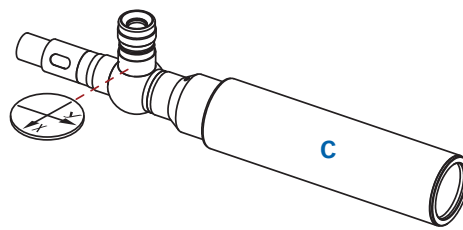
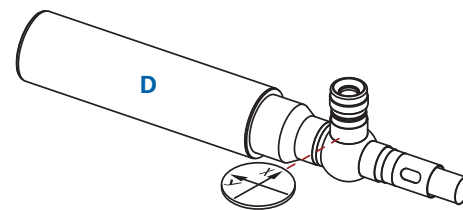

Figure D:
Horizontal use
from right to left



Examples for reticle combinations

(the reticle combinations are valid for autocollimators as well as for combinations testing telescope/collimator):

- **Determination of the wedge error of optical components:**
Collimator reticles: Diaphragms (208 740...208 759)
Eyepiece reticles: Crossline (208 111...208 115)
or
Collimator reticles: Crossline (208 111...208 118)
Eyepiece reticle: mm-scale (208 304)
- **Fast angle measurement**
Collimator reticles: Polar coordinate reticle (208 241, 208 860)
or mm-scale (208 401)
Eyepiece reticles: Crossline (208 111... 208 115)
- **Adjustment for sharpness of optical systems and testing for resolution**
Collimator reticles: Siemens star (208 201, 208 202)
or resolution test (208 211...208 217)
Eyepiece reticles: Crossline (208 111...208 115)
- **Adjustment of an autocollimator to a mirror or of a collimator to a telescope**
Collimator reticles: Crossline (208 111...208 118)
Eyepiece reticles: Double crossline (208 123, 208 125, 208 127)
The reticle should be chosen so that, in symmetry adjustment, a bright gap appears between the double crossline and single crossline.
- **Angle measurement (Determination of angle deviations)**
Collimator reticles: Crossline (208 111... 208 118)
Eyepiece reticles: Arc minute graduations (208 411...208 431)
or line-division (208 436 ... 208 443)
For use in autocollimators/collimators with reticle turret
Collimator reticles: Arc minute graduations (208 811... 208 815)
Eyepiece reticles: Crossline (208 111...208 115)

CROSSLINE RETICLES

Ord.-No.	Description	Line width
208 111	Crossline reticle 0,010	0,010
208 112	Crossline reticle, negative 0,010	0,010
208 113	Crossline reticle 0,020	0,020
208 115	Crossline reticle 0,040	0,040
208 117	Crossline reticle, negative 0,060	0,060
208 118	Crossline reticle, negative 0,35	0,35

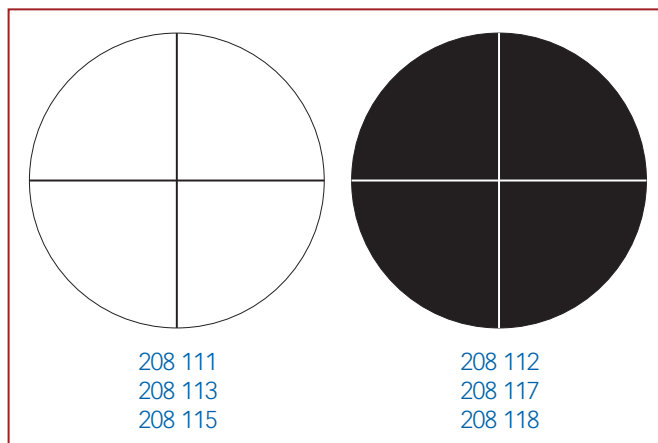

DOUBLE CROSSLINE RETICLES

Ord.-No.	Description	Line spacing
208 123	Double crossline reticle 0,020	0,02
208 125	Double crossline reticle 0,040	0,04
208 127	Double crossline reticle 0,060	0,06

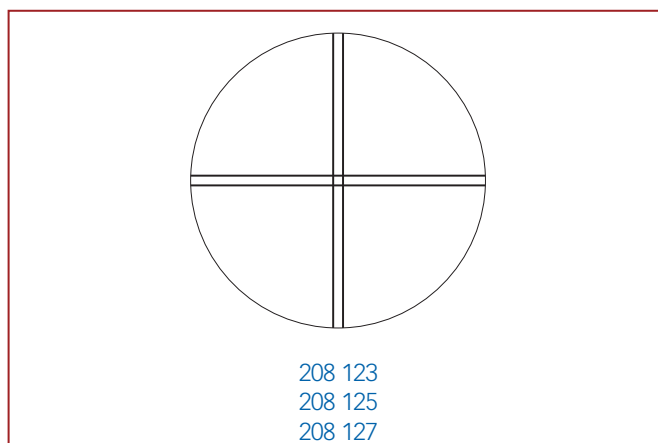

TOLERANCE RETICLES

Ord.-No.	Description	For instrument
208 502	Tolerance reticle with cross	K 90
208 503	Tolerance reticle with coordinate graduation $\pm 2,5^\circ$	K 90
208 506	Tolerance reticle with coordinate graduation $\pm 2,5^\circ$	K 90

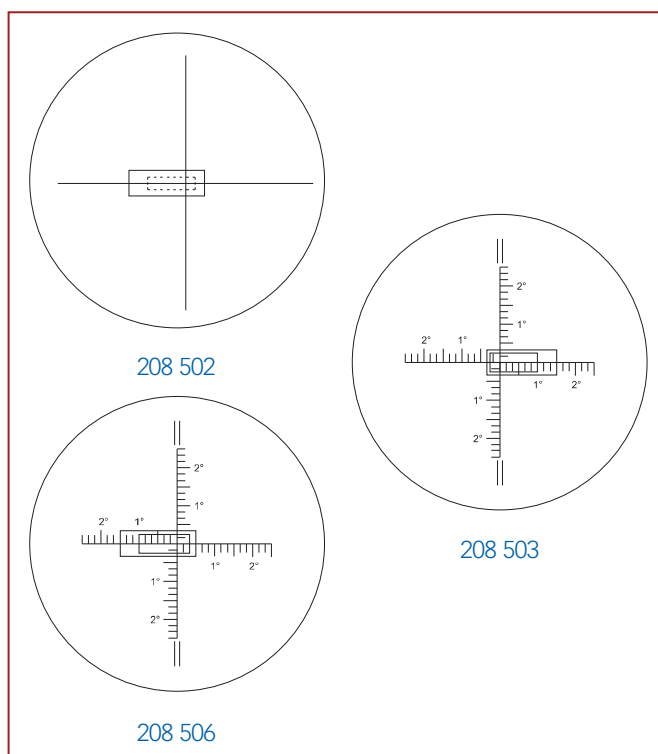

RETICLES

RETICLES WITH ANGLE GRADUATION

For use as
eyepiece graduation

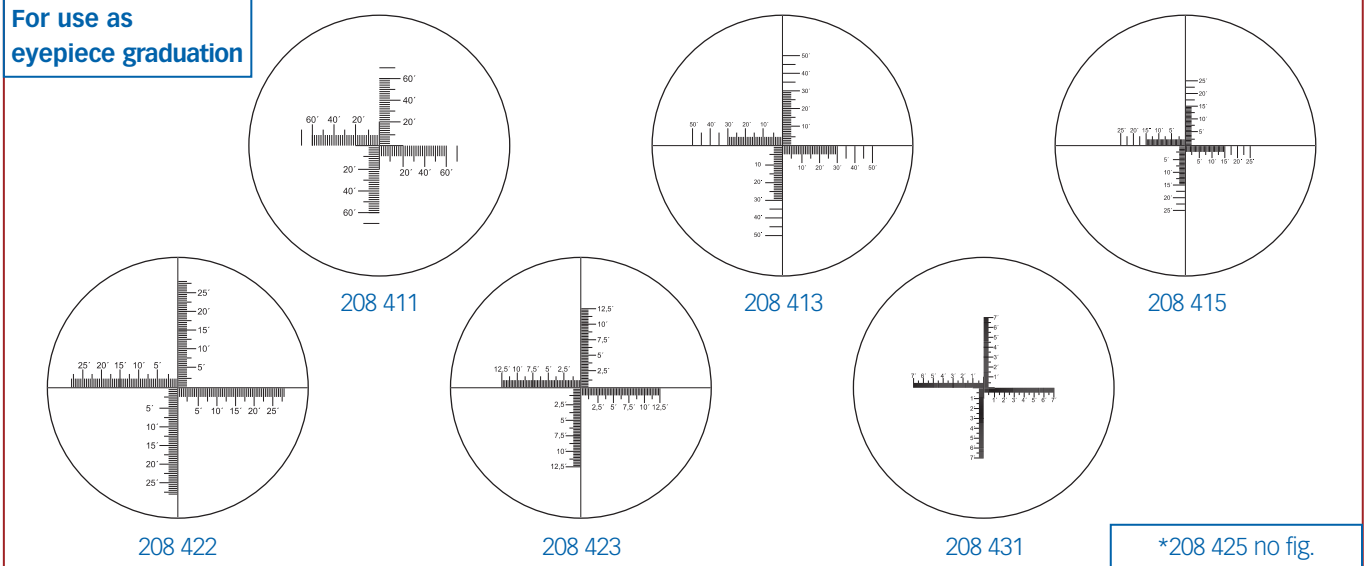

*208 425 no fig.

Ord.-No.	Total range of graduation	Range of fine graduation	Smallest interval	To be estimated	For instrument
208 411	$\pm 60'$	$\pm 60'$	2'	30"	AK 90
208 413	$\pm 50'$	$\pm 30'$	1'	15"	AK 140
208 415	$\pm 25'$	$\pm 15'$	0,5'	10"	AK 200
208 422	$\pm 25'$	$\pm 25'$	0,5'	6"	AK 300
208 423	$\pm 12,5'$	$\pm 12,5'$	0,25'	3"	AK 500
208 425*	$\pm 10'$	$\pm 10'$	0,25'	3"	AK 600
208 431	$\pm 7'$	$\pm 5'$	0,1'	1"	AK 1100

For use as
collimator reticle

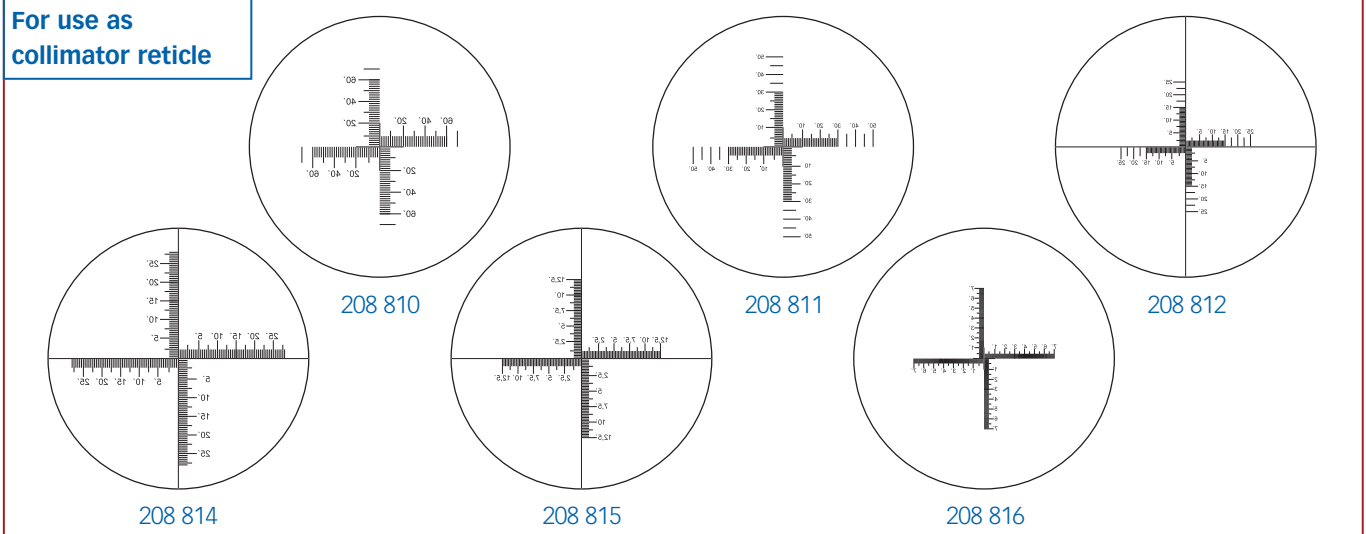

Ord.-No.	Total range of graduation	Range of fine graduation	Smallest interval	To be estimated	For instrument
208 810	$\pm 60'$	$\pm 60'$	2'	30"	AK 90
208 811	$\pm 50'$	$\pm 30'$	1'	15"	AK 140
208 812	$\pm 25'$	$\pm 15'$	0,5'	10"	AK 200
208 814	$\pm 25'$	$\pm 25'$	0,5'	6"	AK 300
208 815	$\pm 12,5'$	$\pm 12,5'$	0,25'	3"	AK 500
208 816	$\pm 7'$	$\pm 5'$	0,1'	1"	AK 1100

RETICLES WITH LINE GRADUATION

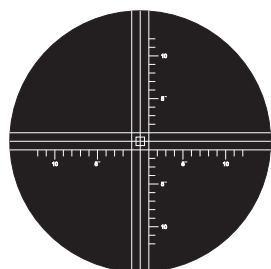

208 435

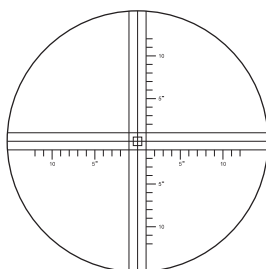

208 436

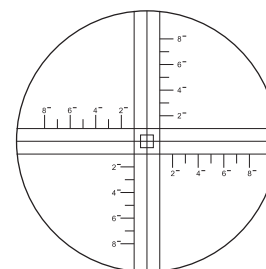

208 437

Ord.-No.	Total range of graduation	Range of fine graduation	Smallest interval	To be estimated	For instrument
208 435	$\pm 12''$	$\pm 12''$	1"	0,2"	AK 200
208 436	$\pm 12''$	$\pm 12''$	1"	0,2"	AK 200
208 437	$\pm 8''$	$\pm 8''$	1"	0,2"	AK 300

DIAPHRAGMS/PINHOLES

Ord.-No.	Description	Remark
208 740	Diaphragm 0,061	corresponds 30" for AK 140; negative
208 741	Diaphragm 0,122	corresponds 1' for AK 140; negative
208 742	Diaphragm 0,244	corresponds 2' for AK 140; negative
208 743	Diaphragm 0,367	corresponds 3' for AK 140; negative
208 744	Diaphragm 0,489	corresponds 4' for AK 140; negative
208 745	Diaphragm 0,611	corresponds 5' for AK 140; negative
208 750	Diaphragm 0,043	corresponds 10" for AK 300; negative
208 751	Diaphragm 0,086	corresponds 20" for AK 300; negative
208 752	Diaphragm 0,131	corresponds 30" for AK 300; negative
208 753	Diaphragm 0,262	corresponds 1' for AK 300; negative
208 754	Diaphragm 0,526	corresponds 2' for AK 300; negative
208 755	Diaphragm 0,790	corresponds 3' for AK 300; negative
208 791	Diaphragm 0,367	corresponds 3' for AK 140

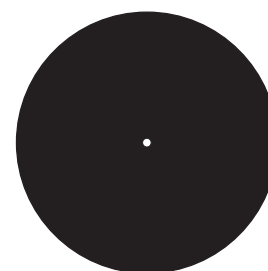

208 740 208 750
 208 741 208 751
 208 742 208 752
 208 743 208 753
 208 744 208 754
 208 745 208 755

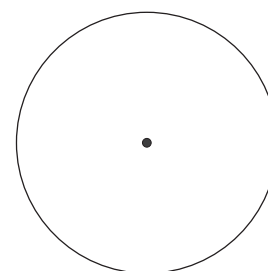

208 791

RETICLES

RETICLES WITH CONCENTRIC CIRCLES

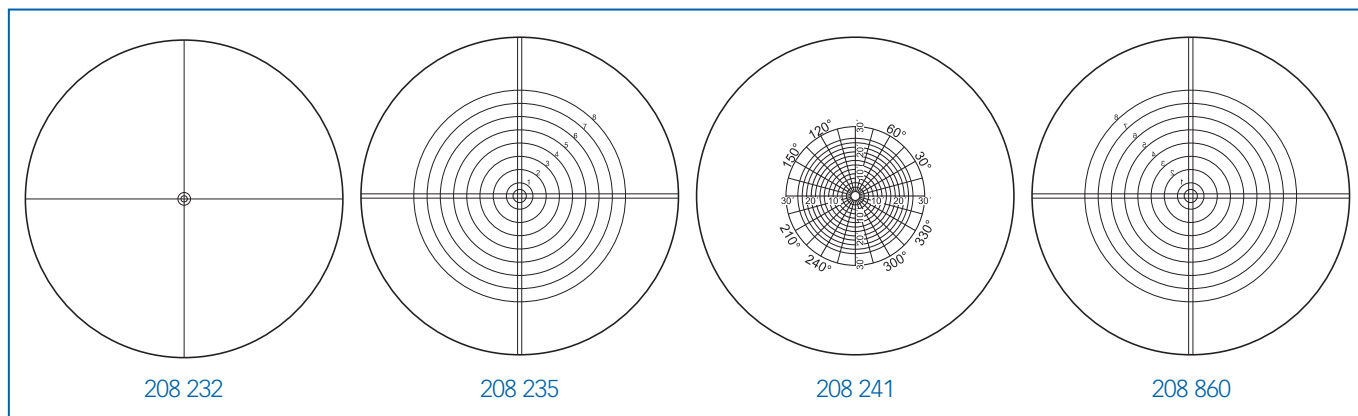

Ord.-No.	Description	Remark
208 232	Concentric circles 0,168-0,38	Ø 0,168 mm; 0,38 mm, crossline 0,01
208 235	Concentric circles 0,5-8 double crossline	Ø 0,5; 1; 2; 3; 4; 5; 6; 7; 8 mm; double crossline line space 0,04
208 241	Polar coordinate FK300	2' to 30'; interval 2' for K, F 300
208 860	Concentric circles 0,5-8 double crossline	as 208 235 but mirror imaged

RETICLES WITH SCALES (MM-GRADUATION)

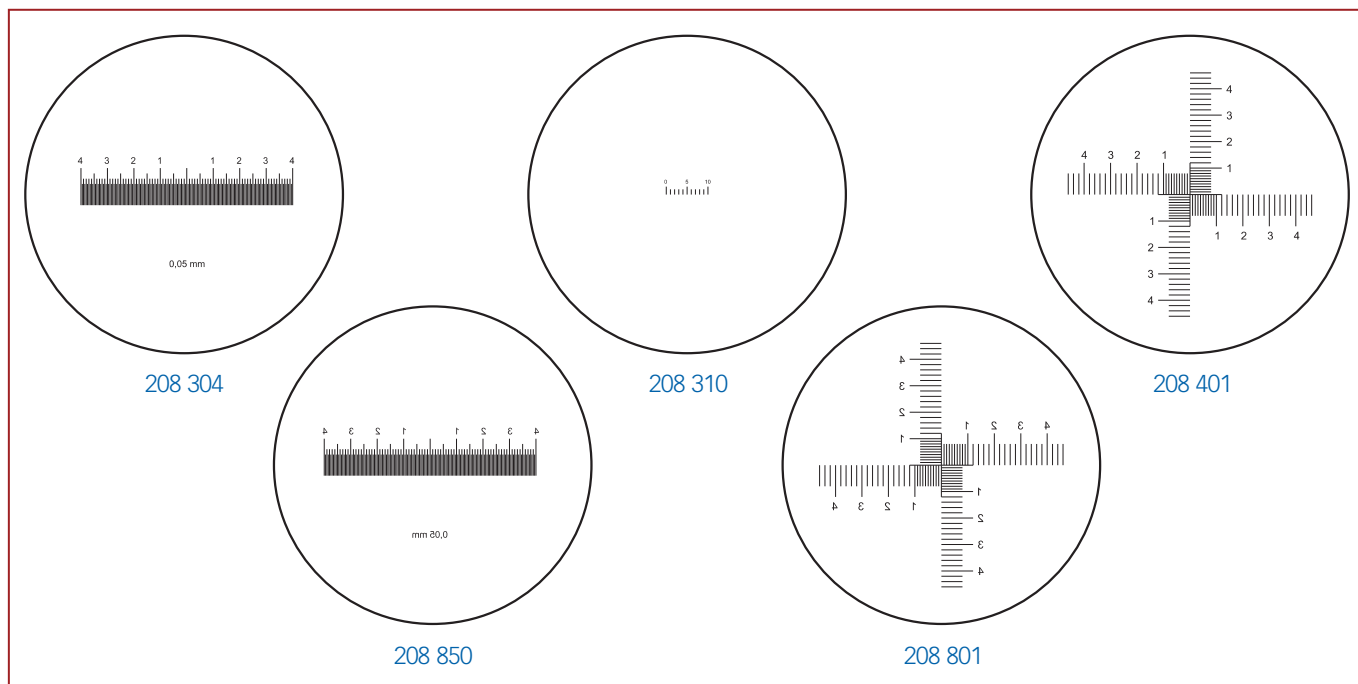

Ord.-No.	Description	Remark
208 304	Scale 4-0-4 graduation 0,050 mm	from -4 to +4 mm; interval 0,05 mm
208 310	Scale 0-10 graduation 0,157 mm	corresponds to 6' for K, F 90
208 401	Coordinate graduation 0,100 mm	from -4,6 to +4,6 mm; interval 0,10 mm
208 850	Scale 4-0-4 graduation 0,050 mm	as 208 304, but mirror-imaged
208 801	Coordinate graduation 0,100 mm	as 208 401, but mirror-imaged

RESOLUTION TESTS

Ord.-No.	Description/Remark
208 211	Resolution test 0,0044...0,252 corresponds USAF-Test group 2 to 7
208 212	Resolution test 0,0044...0,252 negative corresponds USAF-Test group 2 to 7
208 213	Resolution test 0,281...1,0 negative corresponds USAF-Test group 1
208 214	Resolution test 0,562...0,891 negative corresponds USAF-Test group 0
208 215	Resolution test 0,035...0,5 negative corresponds USAF-Test group 1 to 4
208 217	Resolution test 0,0086...0,06 with crossline 0,01 corresponds USAF-Test group 4 to 6

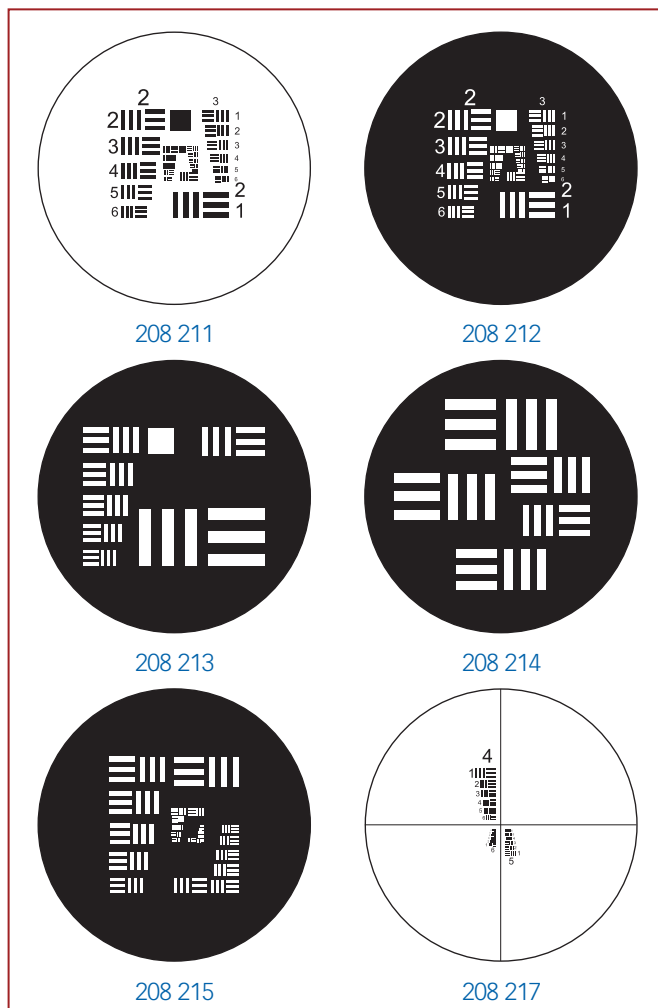

FOCAULT TESTS

Ord.-No.	Description/Remark
208 221	Focault test 0,0315...0,1 negative
208 222	Focault test 0,016...0,0315 negative

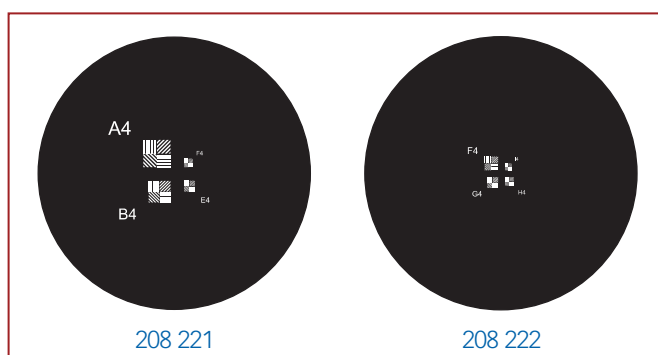

SIEMENS STARS

Ord.-No.	Description/Remark
208 201	Siemens star 2x36 sectors
208 202	Siemens star 60-sectors with crossline 0,02

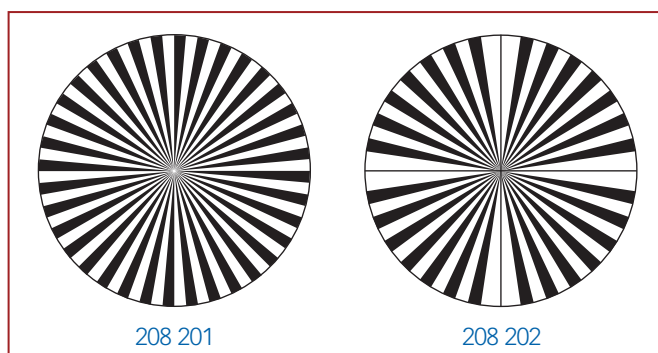

Temporarily not available!

ALIGNMENT SYSTEMS

INTRODUCTION

- FF = Alignment telescopes
- Z = Target
- LOS = Line of sight
- Δs = Deviation from line of sight

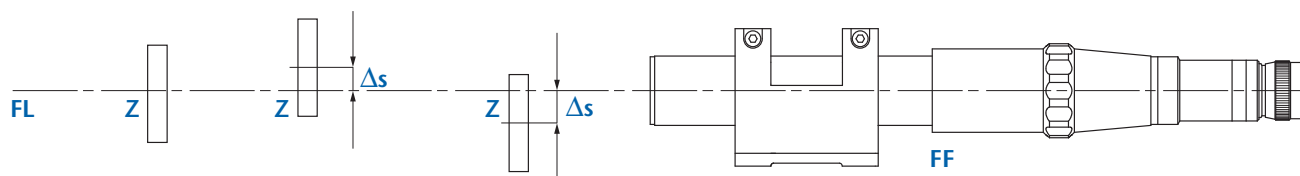

Alignment systems are precision instruments for the alignment of objects on a reference line, which is defined by the line of sight of the system. A special feature of alignment systems is that the direction of the optical axis is conserved during focusing. This property makes them especially useful for the alignment of bore holes, bearings, optical set-ups or for the alignment of guides, axes and planes. Particularly noteworthy on the alignment systems is the wide setting range of objective distances from the tube ending to infinity.

The optical axis and focusing lens are concentrically aligned to the barrel with a high degree of precision. Therefore the use of an alignment telescope for alignment of bore holes, bearings etc. is very simple, as with exact fixing of the alignment telescope

in the reference bore hole or bearing the line of sight is defined already. Depending on measurement task three variants are available.

An alignment collimator serves to precisely project an image of the collimator reticle along a line of reference over varying target distances.

Alignment telescopes serve to establish an accurate line of sight to targets at different distances and determine the deviation of the targets with respect to the reference line.

Alignment autocollimators are a combination of the foregoing variants. They offer the additional possibility of measuring the tilting angle of the target with respect to the reference line. The eyepiece $f=14,7$ mm can be interchanged with eyepieces $f=10$ mm or $f=25$ mm to vary the total magnification and the FOV.

Technical data

Focussing range:	0 - infinity
Accuracy of line sight:	10 μ m
<i>The accuracy of the line of sight denotes the deviation to a straight line measured in the image plane.</i>	
Focal length:	80 mm (at 0 m) to 289 mm (infinity)
Free diameter:	26 mm

Magnification of reticle image

at 0,5 m	5,8x
at 1 m	8,2x
at 2 m	12,6x
at 5 m	24x
at 10 m	42x
at 15 m	61x
at 20 m	77x

ALIGNMENT COLLIMATOR

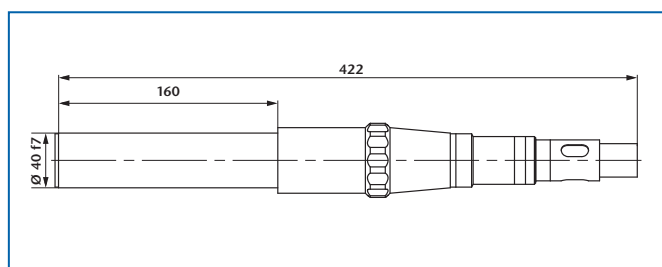

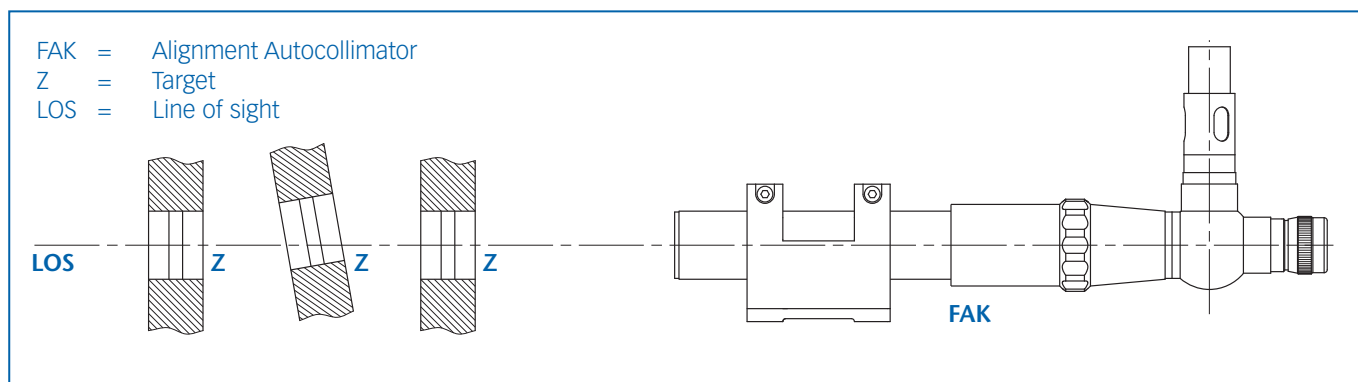

The upper figure shows the use of an alignment autocollimator for alignment of bore holes. The targets are positioned into the bore holes and aligned to the line of sight of the alignment telescope. Additionally the targets can serve as a mirror such that the bore holes can be adjusted with the alignment autocollimator parallel to each other.

The MÖLLER-WEDEL OPTICAL alignment systems are extremely handy. The robust construction with stainless steel tubes guarantees the maintenance of precision even in rough environmental conditions.

As manufacturer of optical test equipment MÖLLER-WEDEL OPTICAL GmbH offers a large range of accessories like targets, holders and fixtures, quick alignment tools and mirrors.

Notes on ordering:

Alignment collimator:

- One reticle and LED-illumination are included in the delivery.

Important: Specify reticle (see page 82) when ordering.

Alignment telescopes:

- Optionally, the telescopes can be equipped with eyepieces having 10 mm or 25 mm focal length.
- One reticle is included in the delivery.

Important: Specify reticle (see page 82). Specify horizontal or vertical use if reticles with lettering (e.g. coordinate division etc.) are used.

Alignment autocollimator:

- Optionally, the autocollimators can be equipped with eyepieces having 10 mm or 25 mm focal length.
- Two reticles and LED-illumination are included in the delivery.

Important: Specify reticles (see page 82). Specify horizontal or vertical use if reticles with lettering (e.g. coordinate division etc.) are used.

Description:

An alignment collimator projects a reticle along a line of reference. The real image of the reticle appears 180° rotated.

Ord.-No.	Description
231 501	FK 300/40

Temporarily not available!

ALIGNMENT SYSTEMS

ALIGNMENT TELESCOPES

WITH STRAIGHT VIEWING

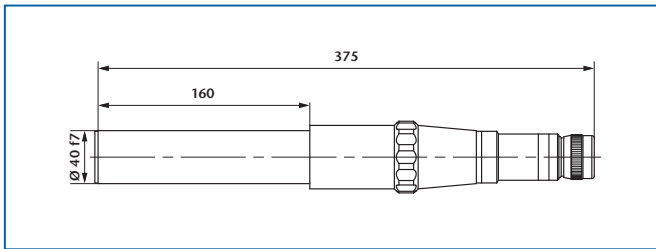

Description:

An alignment telescope with straight viewing has the user's line of sight co-linear with the objective axis. The image of the target appears in the eyepiece focal plane laterally and vertically reverted. These alignment telescopes are preferably used in horizontal direction, where the eyepiece is at eye level.

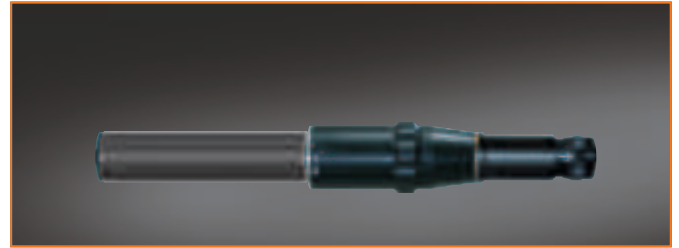

Ord.-No.	Description
231 701	FFG 300/40/14,7

Temporarily not available!



WITH 90°-VIEWING

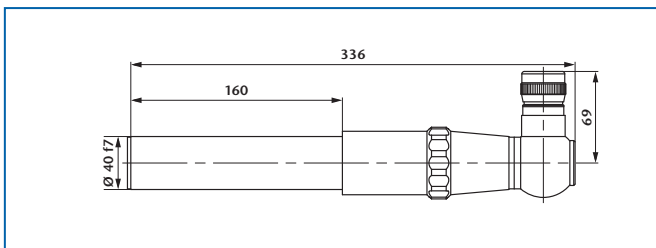

Description:

An alignment telescope with 90°-viewing has the user's line of sight at 90° to the objective axis. By a special deflection optic the target image appears in the eyepiece focal plane upright and right-way round.

These alignment telescopes are preferably used down-looking or on optical tables where a straight viewing is not feasible.

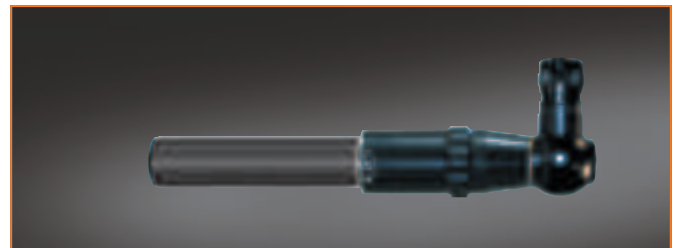

Ord.-No.	Description
231 702	FFR 300/40/14,7

Temporarily not available!



WITH STRAIGHT VIEWING AND DIGITAL DOUBLE MICROMETER

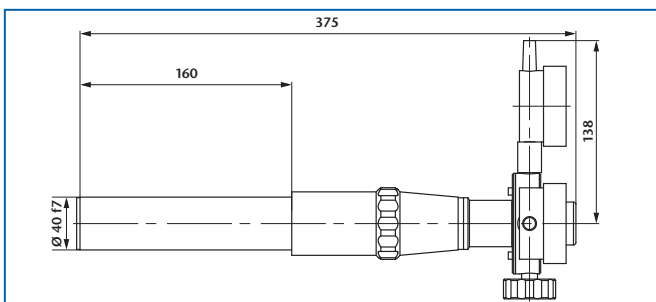

Description:

The alignment telescope with digital double micrometer enables to measure the target image displacement in the eyepiece image plane. If the target distance is known, the target displacement can be calculated.

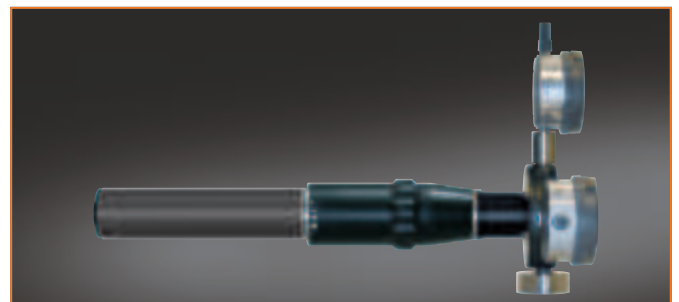

Ord.-No.	Description
231 711	FFG 300/40/14,7 MDD

Temporarily not available!



ALIGNMENT SYSTEMS

ALIGNMENT AUTOCOLLIMATORS

WITH STRAIGHT VIEWING

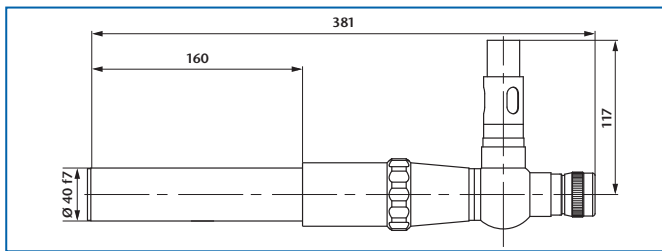

Description:

An alignment autocollimator with straight viewing has the user's line of sight co-linear with the objective axis. The image of the target appears in the eyepiece focal plane laterally and vertically reverted. These alignment autocollimators are preferably used in horizontal direction, where the eyepiece is at eye level.



Ord.-No.	Description
231 901	FAKG 300/40/14,7

Temporarily not available!

WITH 90°-VIEWING

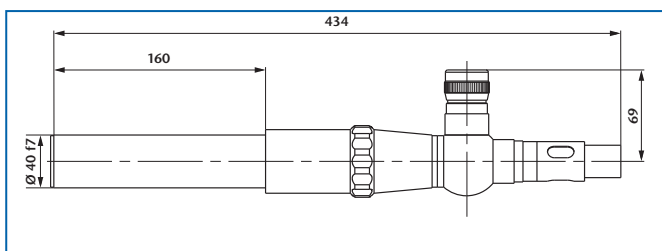

Description:

An alignment autocollimator with 90°-viewing has the user's line of sight at 90° to the objective axis. The target image appears in the eyepiece focal plane upright but laterally reverted. These alignment autocollimators are preferably used down-looking or on optical tables where a straight viewing is not feasible.

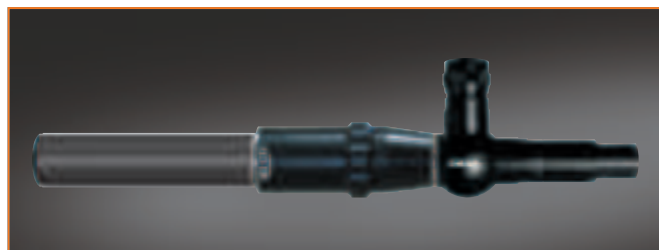

Ord.-No.	Description
231 902	FAKR 300/40/14,7

Temporarily not available!

WITH STRAIGHT VIEWING AND DIGITAL DOUBLE MICROMETER

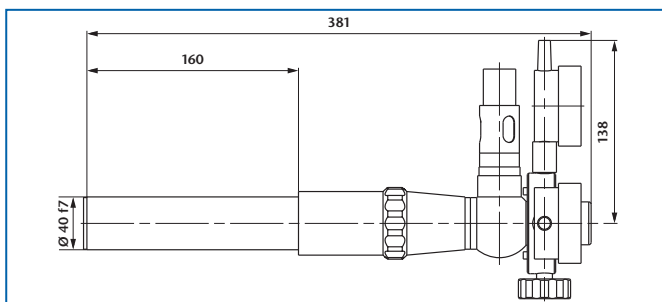

Description:

An alignment autocollimator with digital double micrometer enables to measure the target image displacement in the eyepiece image plane. If the target distance is known, the target displacement can be calculated. Additionally, the tilting angle of the target with respect to the LOS can also be measured.

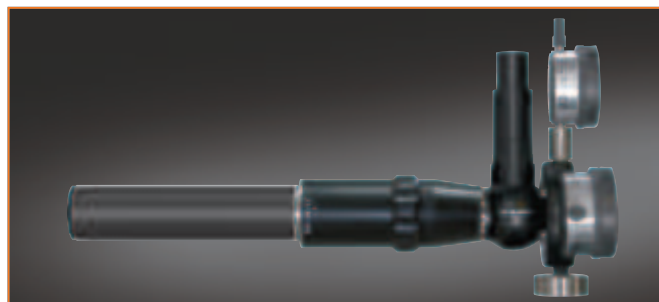

Ord.-No.	Description
231 911	FAKG 300/40/14,7 MDD

Temporarily not available!

OTHER INSTRUMENTS

INSTRUMENTS FOR THE OPTICAL WORKSHOP

Besides the modular designed testing telescopes and collimators MÖLLER-WEDEL OPTICAL offers a whole lot of other telescopes and collimators for diverse measuring tasks in the optical workshop.

For alterations of the magnification interchangeable eyepiece $f=10$ mm and $f=25$ mm can be used as an option.

DIOPTR TELESCOPES

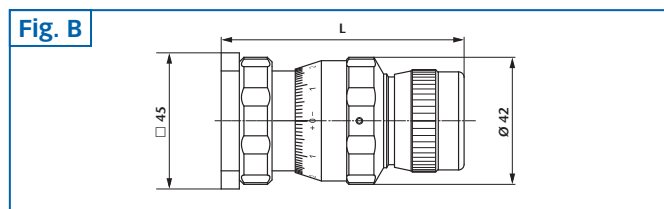
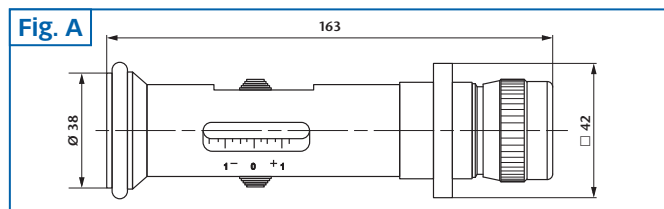

Description:

Diopter telescopes are adjustable focus telescopes that serve the measurement of optical power of lenses in diopter. The measuring result can be directly read from the diopter graduation.



Application examples:

- Fast testing of optical power
- Testing the diopter graduation and infinity adjustment of eyepieces
- For additional enlargement on telescopes, e.g. when adjusting reticles
- As Reading Telescope in the negative distance range

Ident.-Nr.	Description	Meas. range	Scale division	Field of view at	Focal length	L	Fig.
233 202	Diopter telescope $\pm 1,5$	+1,5 to -1,5 dpt	0,25 dpt	6°	90 mm	-	A
233 212	Diopter telescope +6,0/-3,0	+6,0 to -3,0 dpt	0,20 dpt	11°	50 mm	79...99	B
233 222	Diopter telescope +0,2/-5,8	+0,2 to -5,8 dpt	0,20 dpt	11°	50 mm	90...110	B
233 234	Diopter telescope $\pm 5,0$	+5,0 to -5,0 dpt	0,10 dpt	13°	40 mm	76...93	B

DYNAMETER

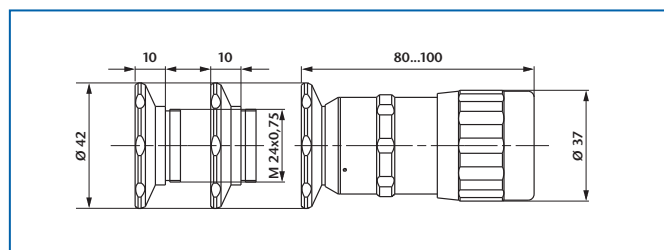

Description:

- For measurement of telescope magnification
- For diameter measurement of the exit pupil
- For measurement of the distance between exit pupil and eyepiece
- Lens magnification 7,5x



Ord.-No.	Description
233 241	Dynameter
233 245	Tube attachment 10 mm

READING TELESCOPES WITH FOCUSING ADJUSTMENT

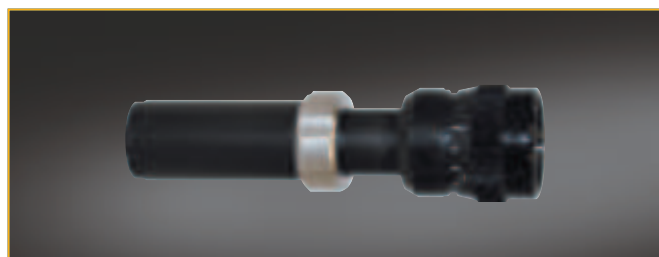
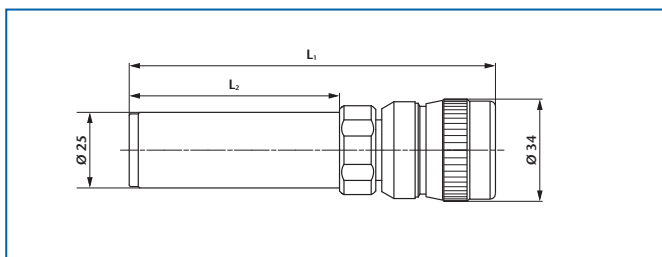

Description:

- For the magnified representation of remote objects
- Reticle 208 111 (crossline 10 μm)
- Tube diameter \varnothing 25 mm
- Focal length objective $f=50$ mm

The telescopes magnification can be calculated at the infinity settings as follow:

f_1 – Focal length of the objective

f_2 – Focal length of the eyepiece

$$V = f_1 / f_2$$

Ord.-No.	Description	Object distance	Reading magnification	Field of view	L1	L2
233 252	Reading telescope D25 U/105	from to 105 mm	3,4 x 12,0 x	11,5° 14,0 mm	100 mm 136 mm	50 mm
233 255	Reading telescope D25 213/73	from 213 mm to 73 mm	4,7 x 23,0 x	36,0 mm 7,5 mm	117 mm 169 mm	67 mm
233 258	Reading telescope D25 97/51	from 97 mm to 51 mm	14 x 52 x	12,5 mm 3,3 mm	141 mm 210 mm	91 mm

SQUARE BODY TELESCOPES AND COLLIMATORS

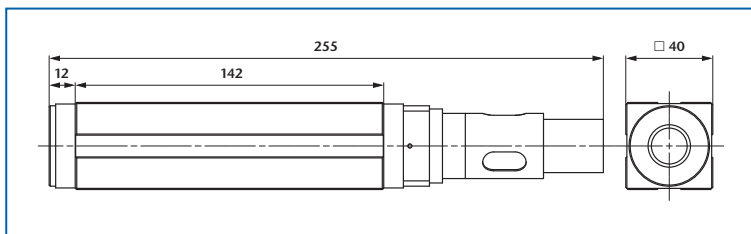
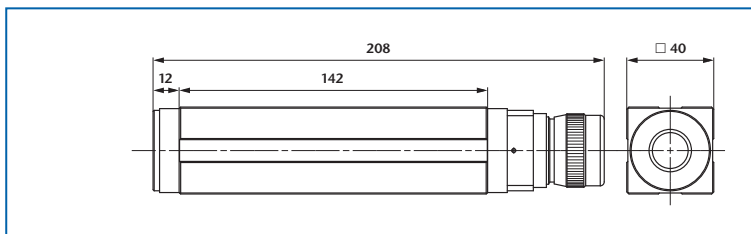

Description:

- For use on plane reference surfaces
- Measurement for 180°-reversion
- Square body with ground surface
- Parallelism of optical to mechanical axes: $< 10''$
- Eyepiece and illumination are freely interchangeable
- Telescope magnification 9,5 x
- Focal length objective 140 mm
- Field of View (with eyepiece $f=14,7$ mm) 4,0°
- clear aperture objective 16 mm

Ord.-No.	Description	Eyepiece	Illuminator	Reticle
233 101	FQ 140/40	$f=14,7$	–	208 125 Double crossline 0,04
233 103	KQ 140/40	–	6V/5W	208 111 Single crossline 0,01

ACCESSORIES

FIXTURES

CLAMP FIXTURE D40/ONE-SIDED

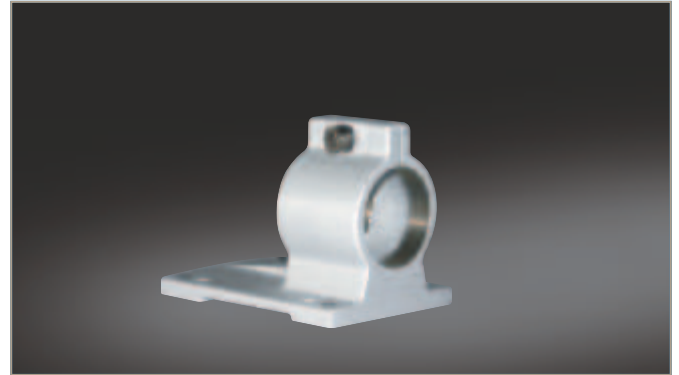
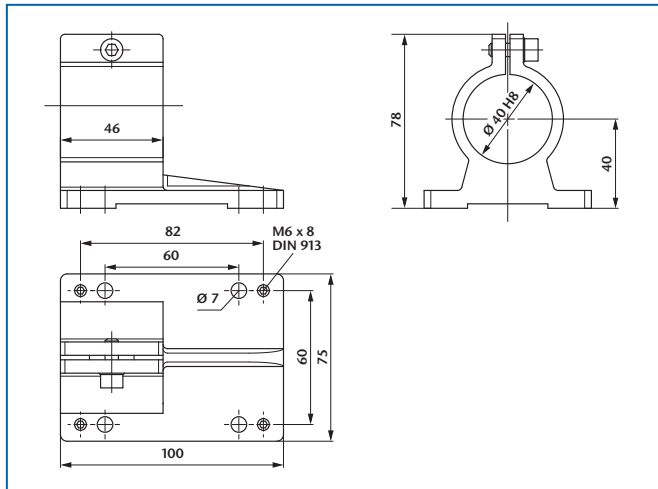

Ord.-No.	Description
223 002	Clamp fixture D40/one-sided

CLAMP FIXTURE D40/DOUBLE-SIDED

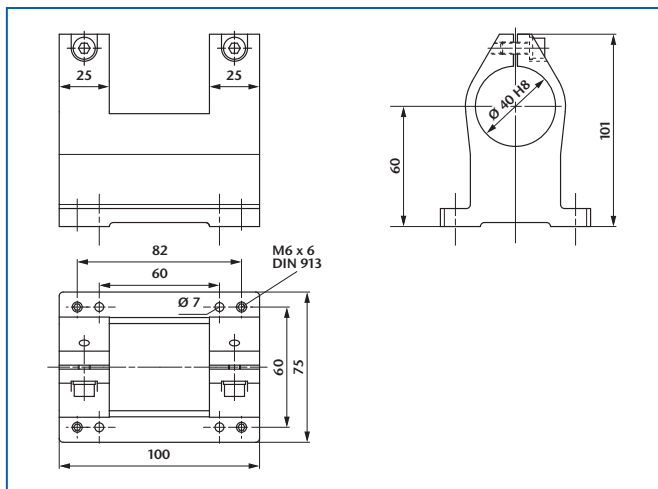

Ord.-No.	Description
223 008	Clamp fixture D40/double-sided

CLAMP FIXTURE D65/DOUBLE-SIDED

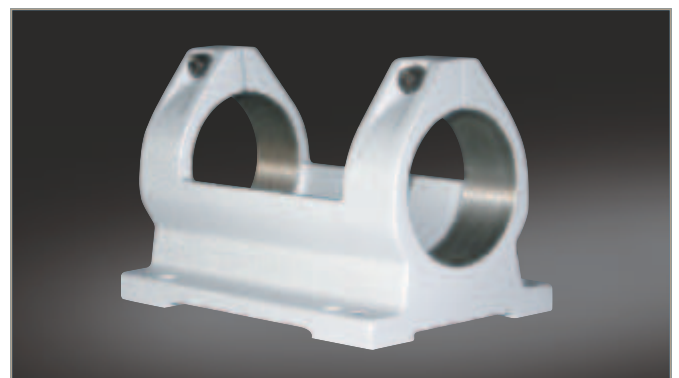
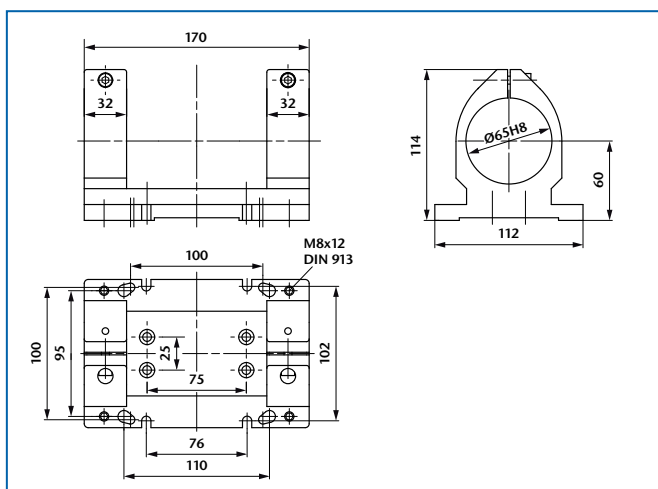

Ord.-No.	Description
223 003	Clamp fixture D65/double-sided

CLAMP FIXTURE D105

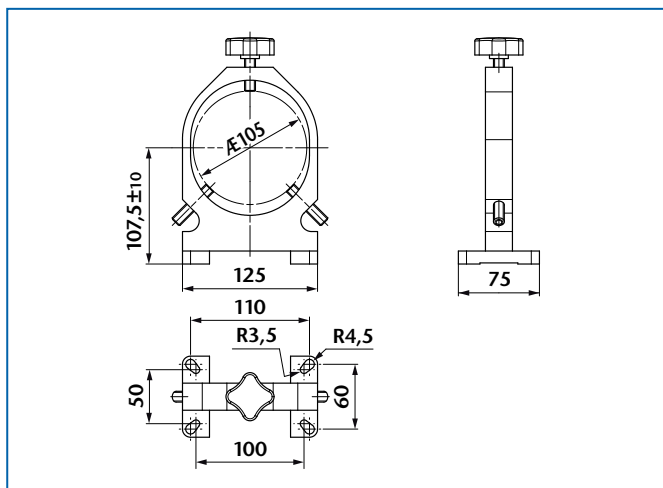

Ord.-No.	Description
223 064	Clamp fixture D105

CLAMP FIXTURE D128

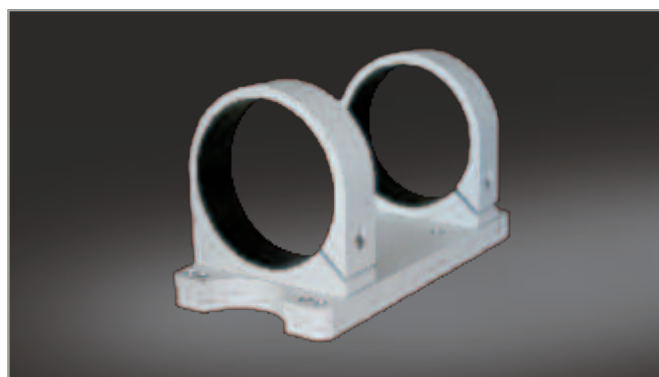
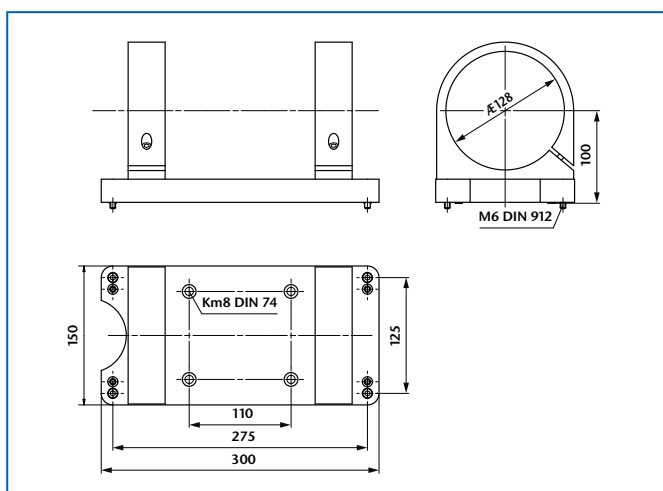

Ord.-No.	Description
223 038	Clamp fixture D128

CLAMP FIXTURE-SET

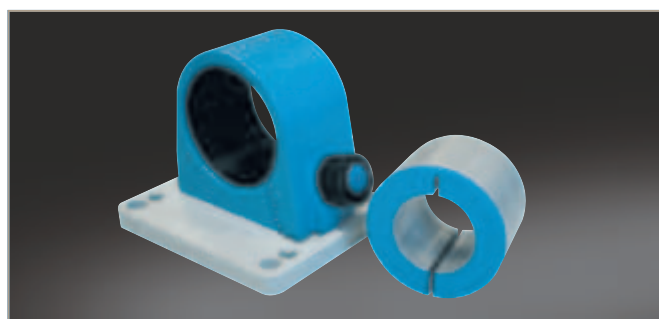
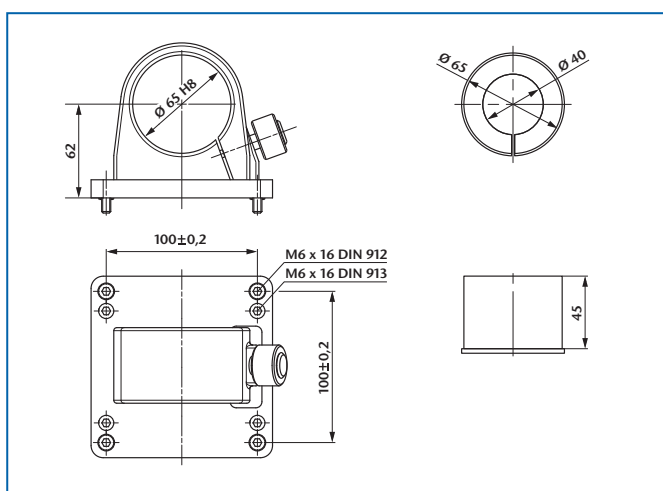

Ord.-No.	Description
223 035	Clamp fixture D40 (223 037 + 223 035 01)
223 037	Clamp fixture D65
223 035 01	Adapter D40

ACCESSORIES

FIXTURES

ADJUSTABLE HOLDERS

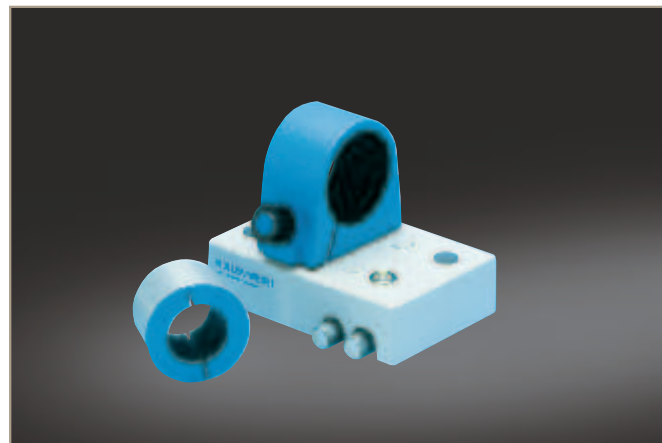
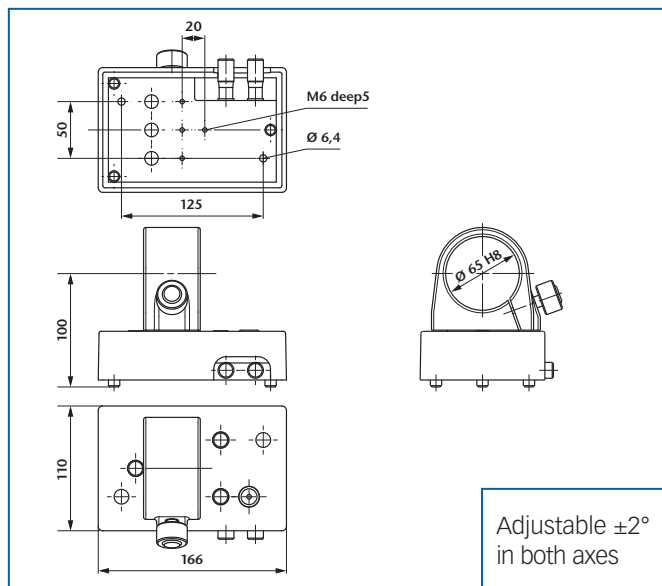

Ord.-No.	Description
223 056	Adjustable holder D65
223 035 01	Adapter D40

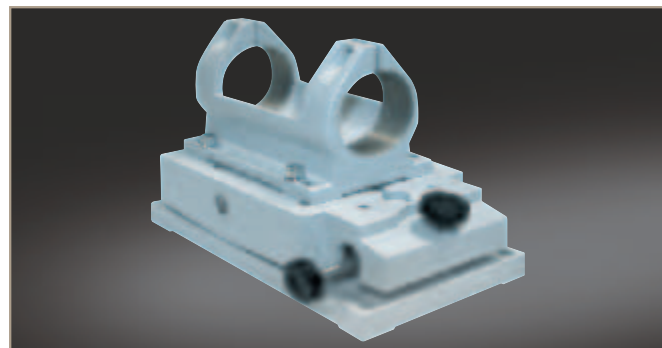
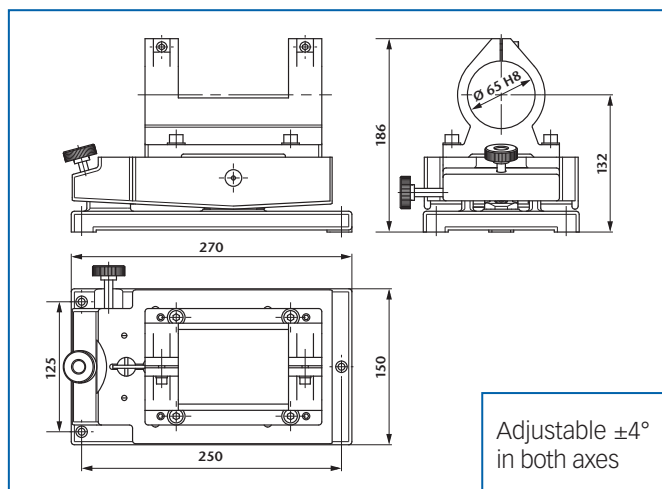

Ord.-No.	Description
223 023	Adjustable holder D40
223 024	Adjustable holder D65

TRIPOD FOR ADJUSTABLE HOLDERS

Ord.-No.	Description
223 080	Tripod for 223 023/024
223 082	Tripod for 223 056



VERTICAL STANDS FOR AUTOCOLLIMATORS MODULAR SYSTEM

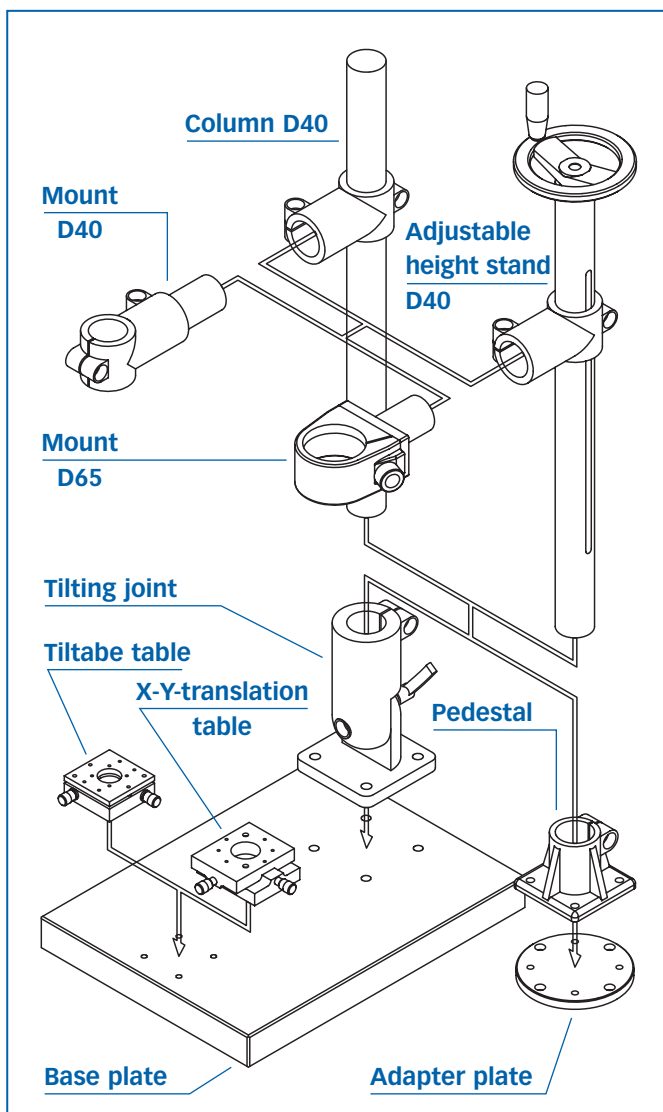

Components						
						Column D40
						Adjust. height stand D65
						Mount D40
						Mount D65
						Pedestal
						Tilting joint
						Base plate
						Adapter plate
						Tilttable table
						X-Y-translation table
Models						
•	•	•	•	•	•	Vertical stand D40 with tilttable table Ord.-No. 223 091
•	•	•	•	•	•	Vertical stand D65 with tilttable table Ord.-No. 223 092
•	•	•	•	•	•	Tilttable stand D40 with tilttable table Ord.-No. 223 093
•	•	•	•	•	•	Tilttable stand D65 with tilttable table Ord.-No. 223 094
•	•	•	•	•	•	Adjust. height stand D40 with tilttable table Ord.-No. 223 095
•	•	•	•	•	•	Adjust. height stand D65 with tilttable table Ord.-No. 223 096
•	•	•	•	•	•	Adjust. height stand D40 with X-Y table Ord.-No. 223 097
•	•	•	•	•	•	Adjust. height stand D65 with X-Y table Ord.-No. 223 098

V-PRISM

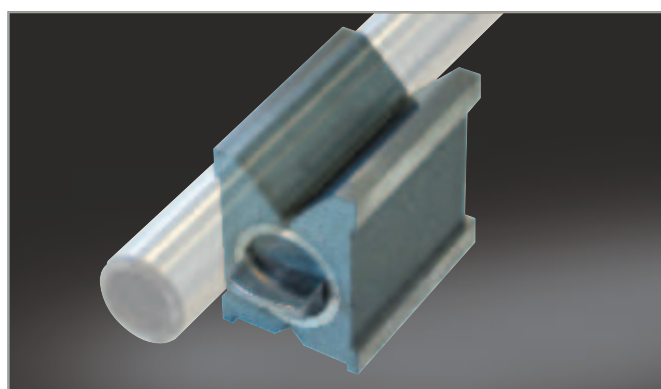
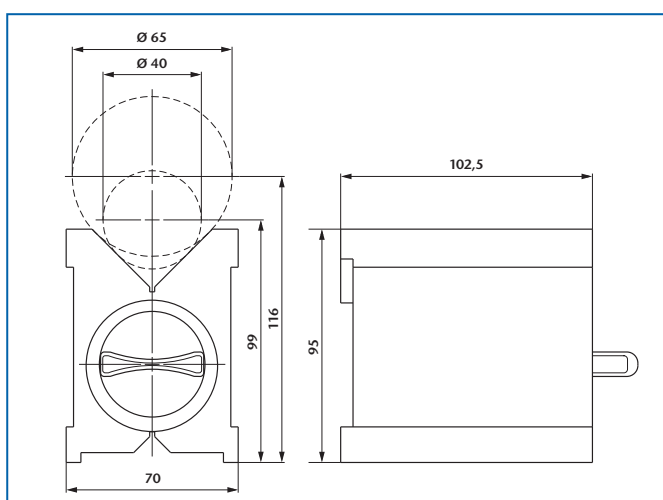

Ord.-No.	Description
223 007	Magnetic prism

ACCESSORIES

ALIGNMENT AIDS

LASER ATTACHMENT D40

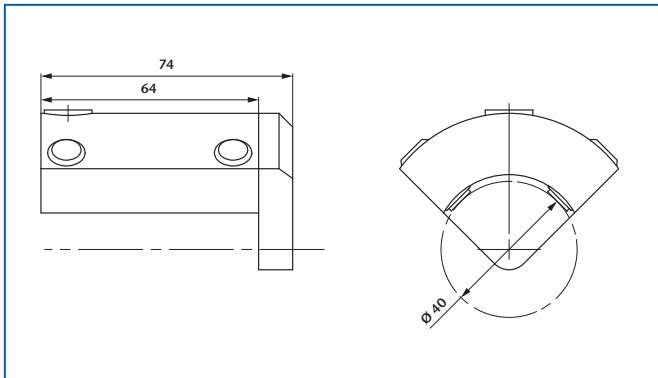

LASER ATTACHMENT D65

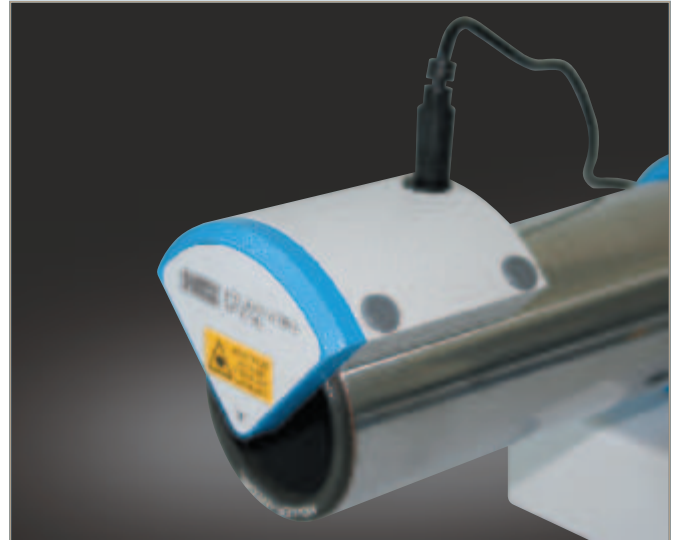
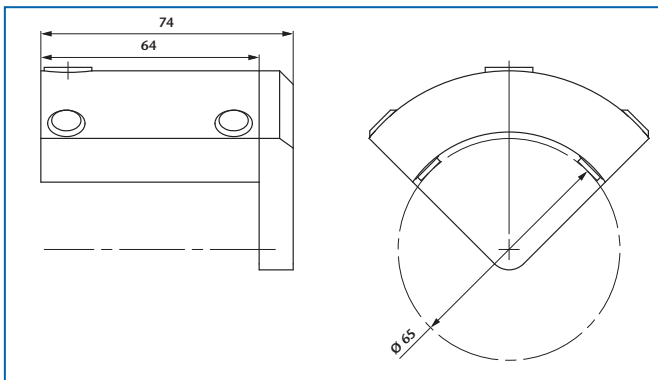

Description:

The laser attachments D40 and D65 are useful for fast coarse alignment of autocollimators. They are especially handy for aligning distant or very small mirrors, polygons and prisms.

Ord.-No.	Description
219 760	Laser attachment D40 with power supply
219 750	Laser attachment D65 with power supply

AC-FINDER PRISM

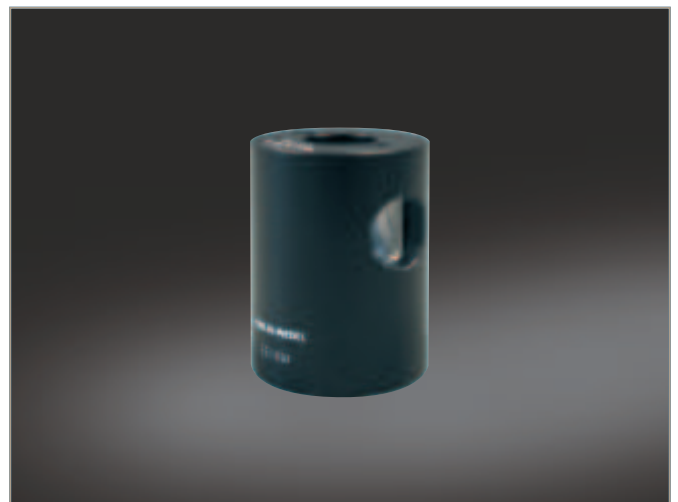
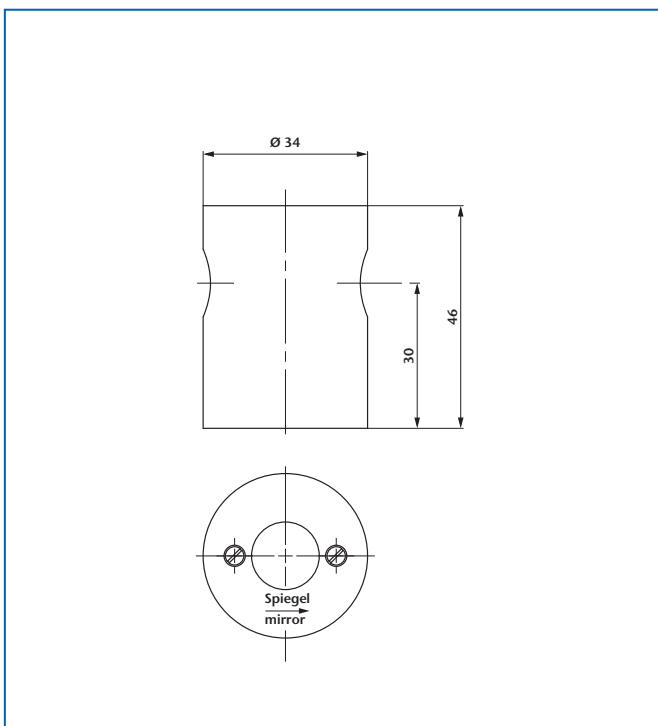

Description:

Das AC-finder prism is designed for alignment of mirrors with respect to autocollimators at short distances.

Ord.-No.	Description
221 031	AK-finder prism

ACCESSORIES

ACCESSORIES FOR OBJECTIVE TUBES

SUPPORTING FLANGE D40

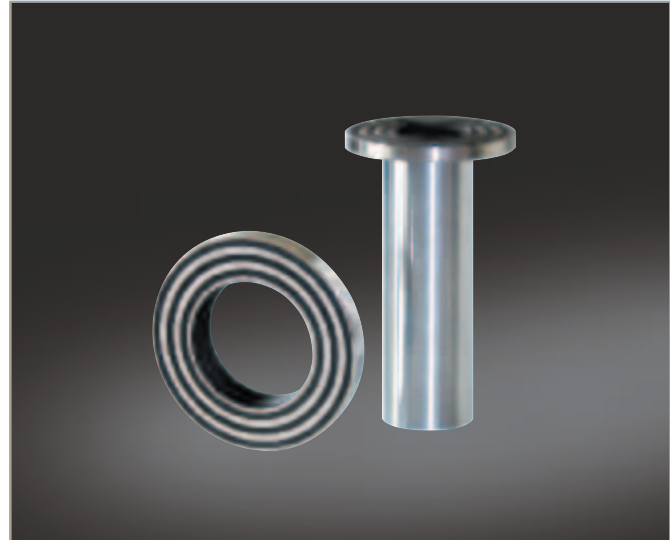
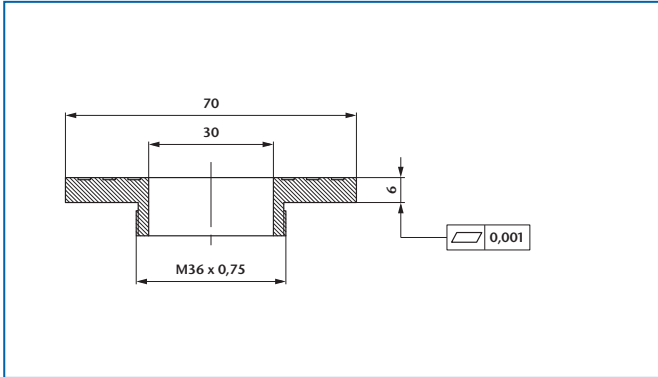

SUPPORTING FLANGE D65

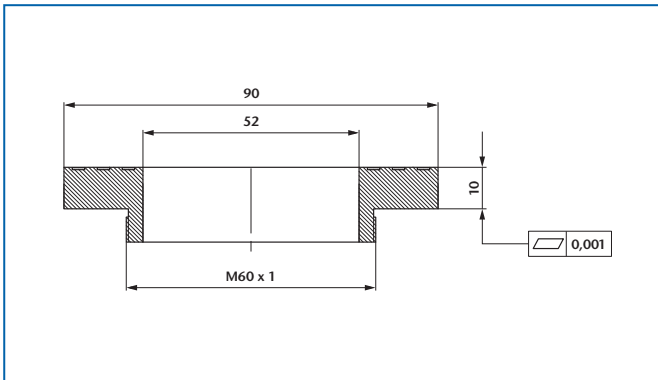

Description:

Supporting flanges of type D40 and D65 are factory aligned perpendicular to the optical axis. They are screwed in front of the objective tubes. Alignment will be lost by unscrewing.

Ord.-No.	Description
221 001	Supporting flange D40
221 003	Supporting flange D65

ACHROMAT ATTACHMENTS IN MOUNT

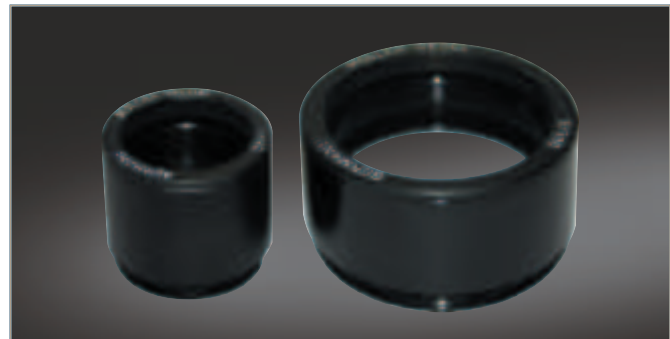
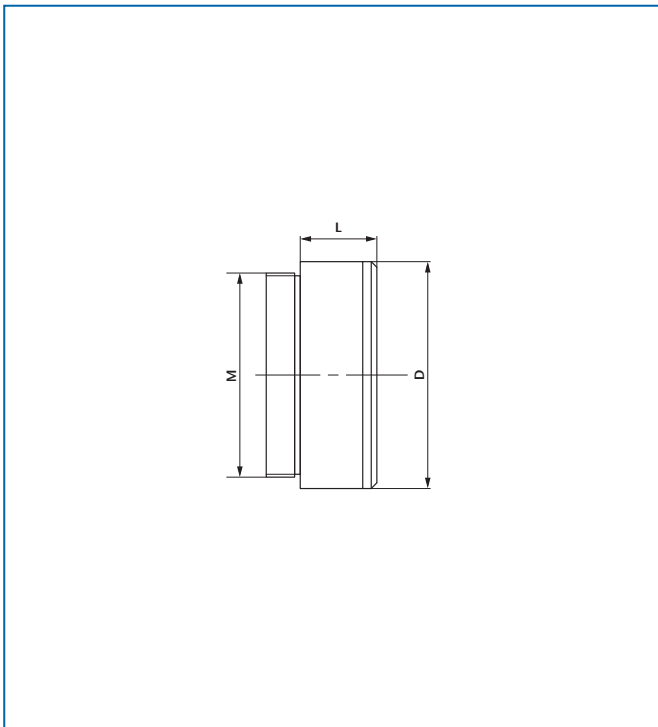

Ord.-No.	Description	M	L	D
221 048	VA f=50/12 D40	M36x0,75	11,0	39,5
221 051	VA f=90/16 D40	M36x0,75	13,5	39,5
221 053	VA f=140/28 D40	M36x0,75	29,5	39,5
221 055	VA f=200/28 D40	M36x0,75	29,5	39,5
221 059	VA f=300/28 D40	M36x0,75	29,5	39,5
221 063	VA f=500/28 D40	M36x0,75	29,5	39,5
221 067	VA f=800/28 D40	M36x0,75	21,5	39,5
221 057	VA f=200/50 D65	M60x1	28,5	64,0
221 061	VA f=300/50 D65	M60x1	28,5	64,0
221 065	VA f=500/50 D65	M60x1	28,5	64,0

ACCESSORIES

MIRRORS

MIRROR D100

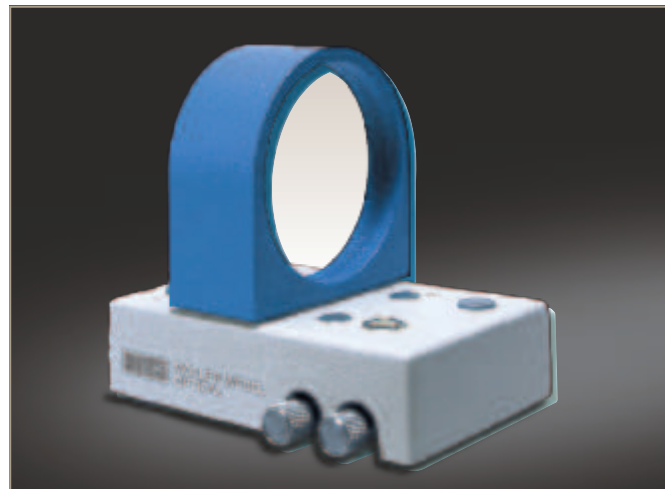
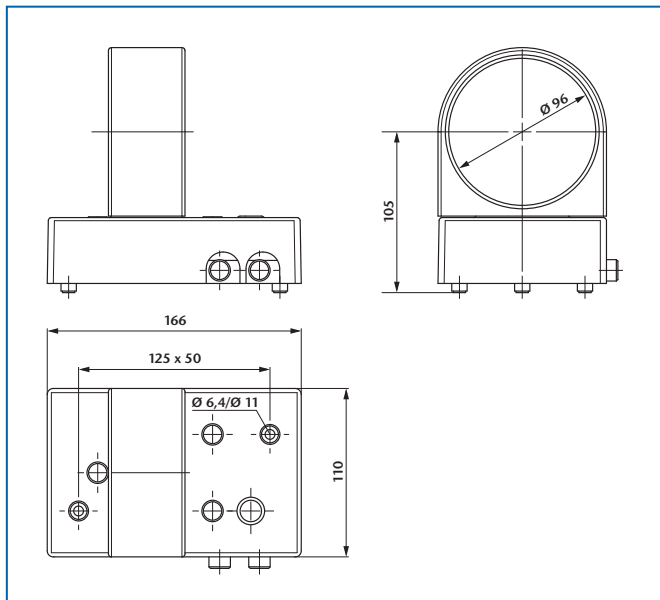

Ord.-No.	Description
223 221	Mirror D100/adjustable, double sided, 2"

MIRROR IN MOUNT

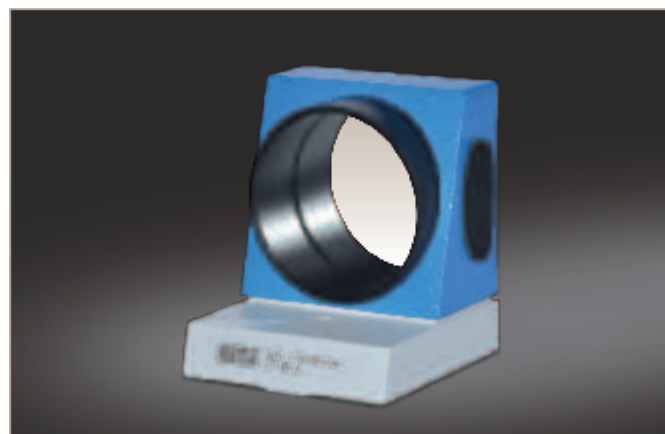
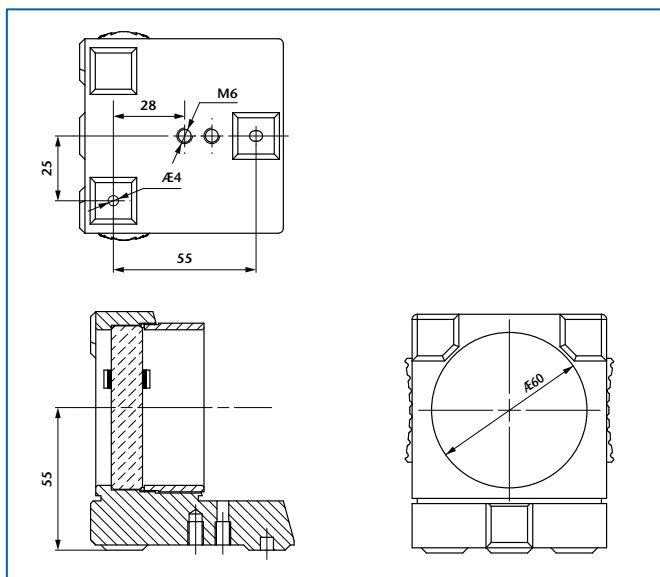

Ord.-No.	Description
223 260	Mirror in mount/one-sided
223 262	Mirror in mount/double-sided, 2"

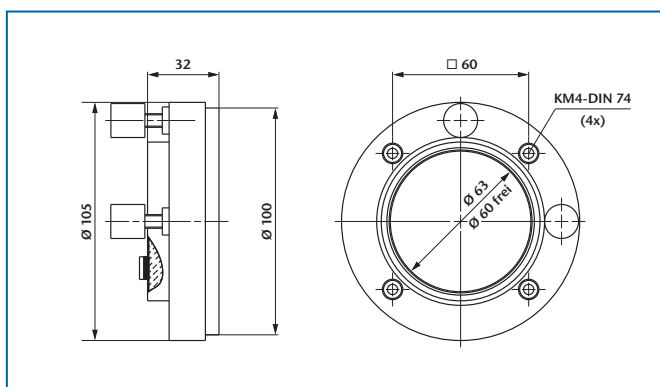

Ord.-No.	Description
223 210	Mirror D63/adjustable, permanent magnetic clamp

BASE 100

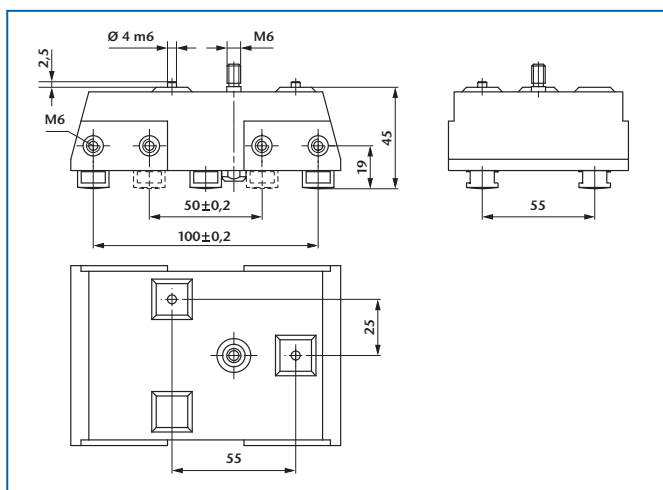

STOP BAR FOR BASE 100

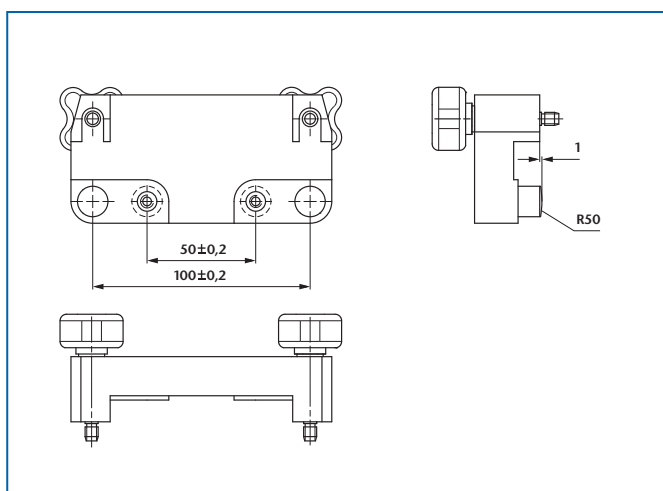

Ord.-No.	Description
223 264	Base 100/50
223 269	Stop bar for base 100/50

MAGNETIC BASE FOR MIRROR

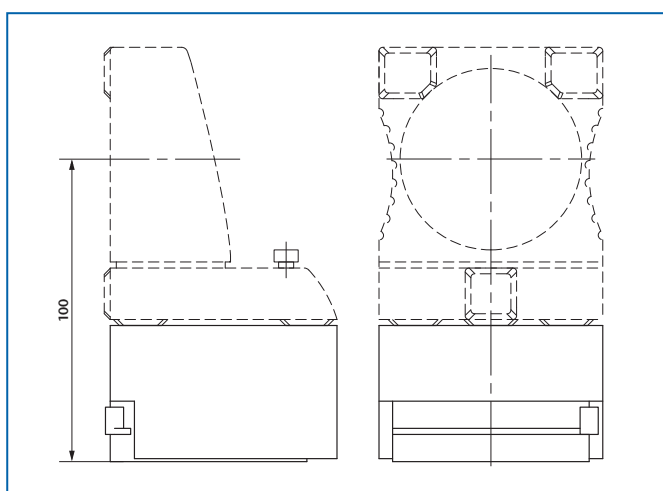

Ord.-No.	Description
223 282	Magnetic base for mirror 223 260/223 262

ACCESSORIES

POLYGON MIRRORS AND AUTOCOLLIMATOR-TEST-WEDGE

POLYGON MIRROR 8 FACES

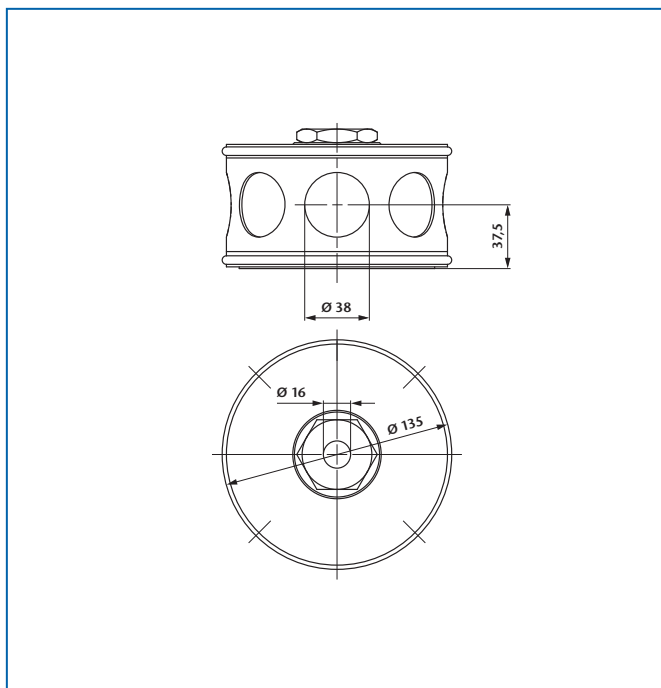

Ord.-No.	Description
205 307	Polygon mirror 8 faces 2"

POLYGON MIRROR 12 FACES

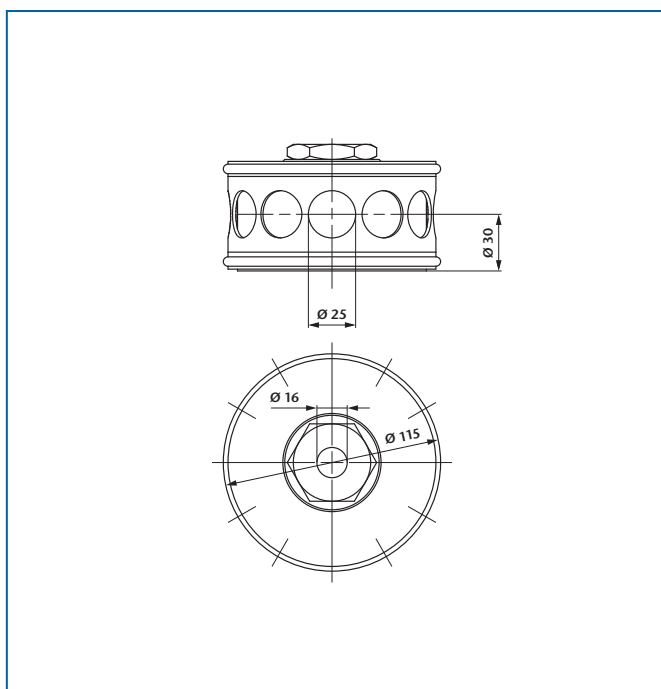

Ord.-No.	Description
205 313	Polygon mirror 12 faces 2"

AUTOCOLLIMATOR-TEST-WEDGE

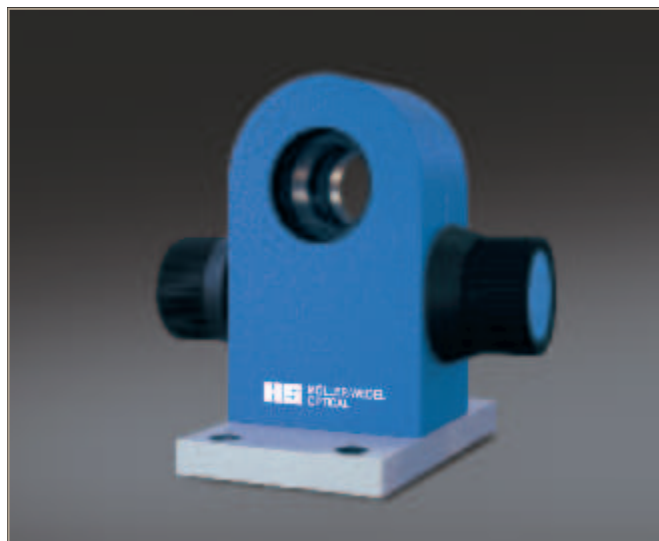
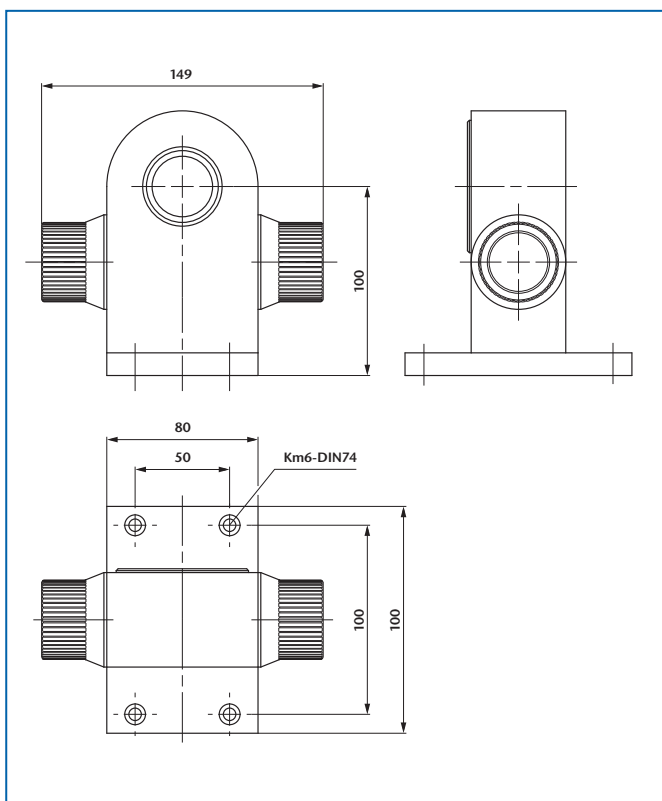

Description:

The certificated Autocollimator-Test-wedge is used as quick reference for on site testing of visual and electronic autocollimators.

Ord.-No.	Description
223 244	Autocollimator-Test-Wedge

ACCESSORIES

MONITOR AND CAMERA-SETS

LIVE-IMAGE-KIT

The basic application of the [Live-Image-Kit](#) is to display the eyepiece image of an optical measuring instrument as e.g. autocollimators, testing telescopes and alignment telescopes or alignment autocollimators on a monitor. The [LiveVIEWER Lite](#) software included in the scope of delivery ensures optimum display. The [LiveVIEWER](#) software is available as an optional extension.

Note: The Live-Image-Kit is useable with all offered eyepieces of the MÖLLER-WEDEL OPTICAL. The size of the image field of the CCD-Camera is depending on the used eyepiece. It is also possible to order the C-Mount-Adapter separately, to connect your own camera type with our visuall optical instruments (e.g. telescopes, autocollimators and alignment systems). We recommend to order also the corresponding eyepiece hull for the C-Mount Adapter. This replace the diopter setting of classic eyepiece hull by the possibility to lock the focus position of the C-Mount adapter.

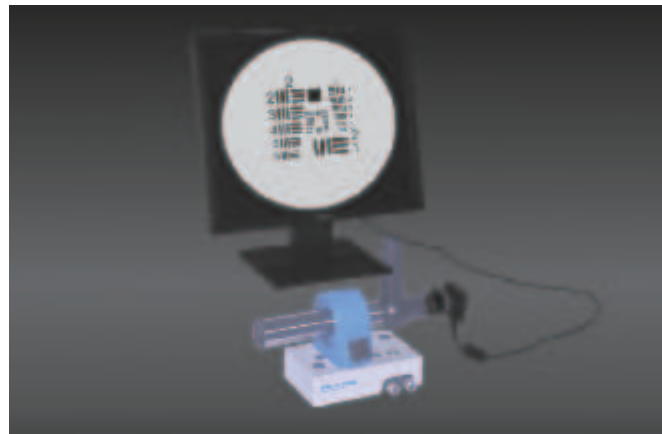

Ord.-No.	Description	Comment
229 931	Live-Image-Kit	
229 933	Video-Mini-PC (Windows® 10)	Can be ordered separately.
133 401 07	C-Mount Adapter	Can be ordered separately, should be always combined with eyepiece hull.
280 385	Okularhülse	Can be ordered with a C-Mount adapter.
773 000 33	USB CMOS Kamera	Monochrome camera with 1:1.8"
229 934	Software LiveVIEWER Lite	Can be ordered separately; only usable in combination with IDS camera.



ACCESSORIES

SOFTWARE

LIVEVIEWER LITE

The LiveVIEWER Lite Software is part of delivery of the Live-Image-Kit but can also be ordered separately.

The Software provides the following features:

- Display of camera live-image
- Digital zoom-function
- Display of synthetic reticle pattern of pre-defined or user-defined reticles
- Manual or automatic brightness control
- Storage of screen-shots

Note: The software runs only in combination with an IDS industry camera.

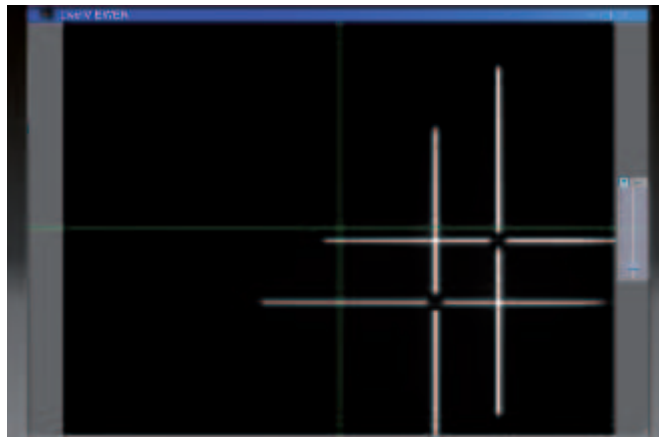

Art.-Nr.	Bezeichnung
229 934	Software LiveVIEWER Lite

LIVEVIEWER (Extended Version)

The LiveVIEWER Software is extended version of the Software LiveVIEWER Lite.

The Software provides the following features:

- Display of camera live-image
- Digital zoom-function
- Display of synthetic reticle pattern of pre-defined or user-defined reticles
- Digital double micrometer function:*
- With relative and absolute measurement mode
- Standard setting in micrometer
- Changable in arcmin or arcsec in the config. settings
- Digital reticle changer
- Manual or automatic brightness control
- Storage of screen-shots

Note: The software runs only in combination with an IDS industry camera.

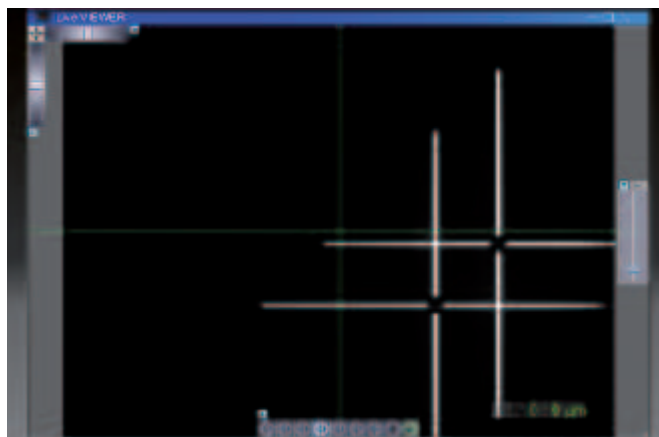

Art.-Nr.	Bezeichnung
229 935	Software LiveVIEWER

* The function is comparable to a digital gauge (e.g. AKG MDD) and does not allow a automatic measurement as the software ELCODirect with an electronic autocollimator of the ELCOMAT direct Product line.

Möller-Wedel Optical GmbH

Rosengarten 10
D-22880 Wedel

Tel.: +49 - 41 03 - 9 37 76 10
Fax: +49 - 41 03 - 9 37 76 60

www.moeller-wedel-optical.com
e-mail: info@moeller-wedel-optical.com