

ELCOMAT[®] direct N - Product Line

Electronic Autocollimators

Möller-Wedel Optical GmbH

Your Specialist for High-Precision Optical Measurement Systems

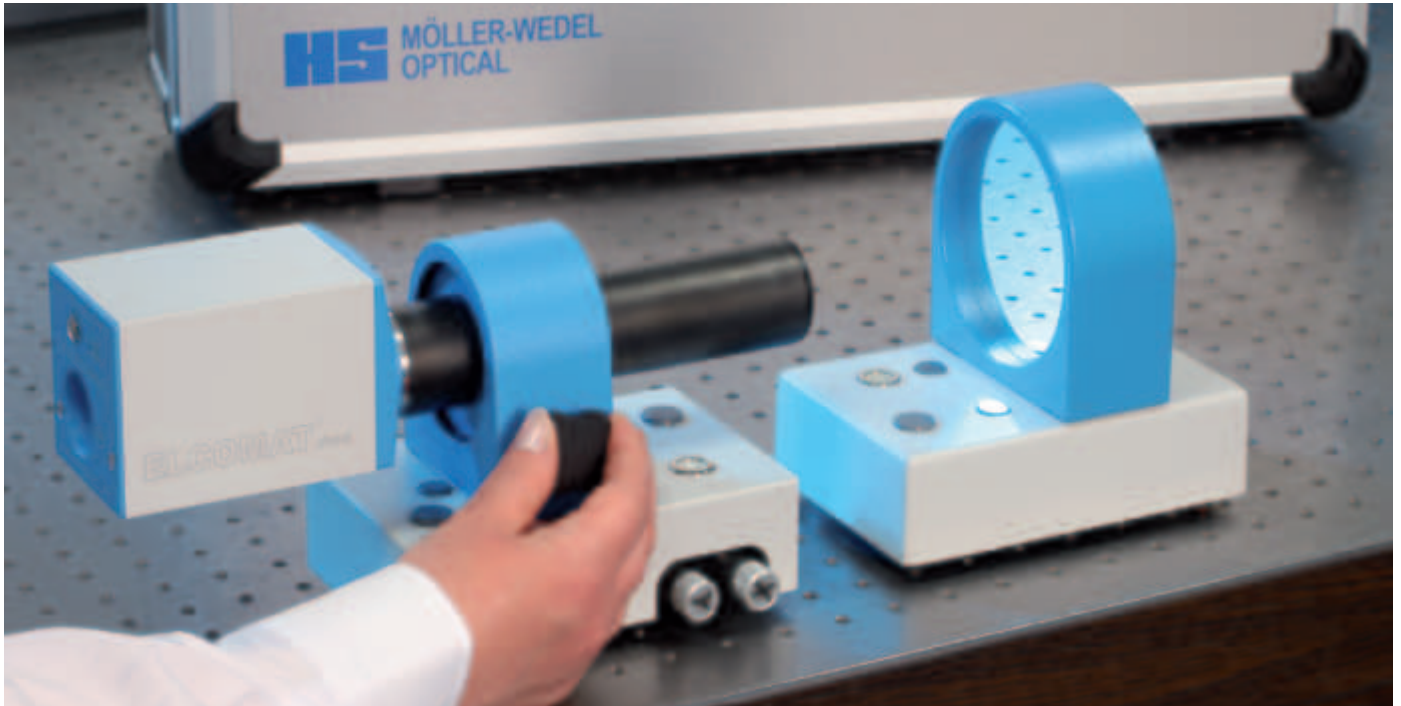

Optical Metrology "Made in Germany" for more than 40 countries worldwide

Möller-Wedel Optical GmbH, based in Wedel near Hamburg, Germany, is a globally active company that develops, manufactures and sells high-precision optical measuring systems for mechanical engineering, the automotive industry, the optical industry, the semiconductor industry, for film camera service and for calibration and research laboratories.

For more than 50 years, the company's optical measuring instruments have enjoyed an excellent reputation worldwide for their quality and durability.

Möller-Wedel Optical is certified according to DIN EN ISO 9001:2015. As the world market leader in the field of small angle metrology, Möller-Wedel Optical operates an EN ISO 17025:2018 accredited calibration laboratory for the dimensional quantity angle - angle standards.

The team of specialists from the fields of optics, optoelectronics, metrology, physics and precision engineering is constantly working on new innovative products and solutions for the demanding measurement tasks of its customers. From research and development to production, Möller-Wedel Optical combines the latest technologies with traditional skills. This ensures the highest quality and precision.

Möller-Wedel Optical GmbH

Our ELCOMAT® Product Line

Autocollimators are optical measuring instruments that measure the smallest changes in the angular position of optical reflectors. They are mainly used for the following measuring tasks: measurement of smallest angles, ultra-precise angle adjustment and angle calibration, quality assurance of machine tools and their components, assembly automation, angular position monitoring.

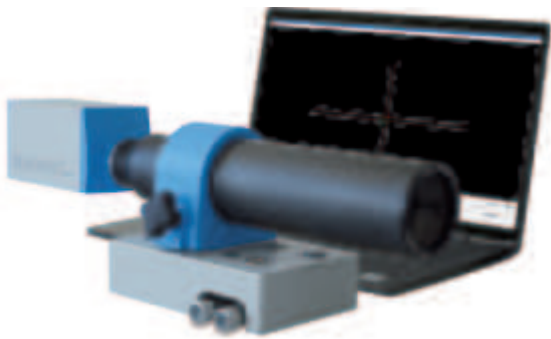

ELCOMAT® direct N

Each ELCOMAT®direct N consists of an autocollimation sensor and the ELCOdirect software, which can be used with Microsoft® Windows and a current PC or laptop. More information can be found on the following pages.

ELCOMAT® vario N

The ELCOMAT®vario N autocollimators are characterized by direct signal digitization in the sensor head, a high degree of user-friendliness and an extended range of functions of the 5000 display unit. They are available with objective tubes of different focal lengths. More information about this product is available at www.moeller-wedel-optical.com.



ELCOMAT® 5000

Compared to its predecessor, the ELCOMAT®3000, the ELCOMAT®5000 not only has a larger measuring range and a better signal-to-noise ratio due to the direct signal processing in the measuring head, but also a 10 times higher measuring frequency. Internal position sensors ensure fast and accurate alignment of the sensor head and "on-the-fly" straightness measurement. More information about this product is available at www.moeller-wedel-optical.com.

ELCOMAT® HR

The ELCOMAT®HR is a measuring instrument for applications with highest accuracy requirements. An ultra-stable mechano-optical design and specially developed evaluation and calibration algorithms are the basis for the excellent accuracy. This makes the ELCOMAT®HR an ideal reference instrument for national calibration institutes. More information about this product is available at www.moeller-wedel-optical.com.



ELCOMAT® direct N Electronic Autocollimator

Autocollimators are optical measuring instruments that measure the smallest changes in the angular position of optical reflectors. In electronic autocollimators, the autocollimation image is detected by CCD lines or a matrix sensor.

The ELCOMAT® direct N is particularly suitable for the following measuring tasks:

- Small angle measurement
- Ultra-precise angle adjustment and calibration
- Wedge and prism angle measurement
- Assembly automation
- Angle position monitoring

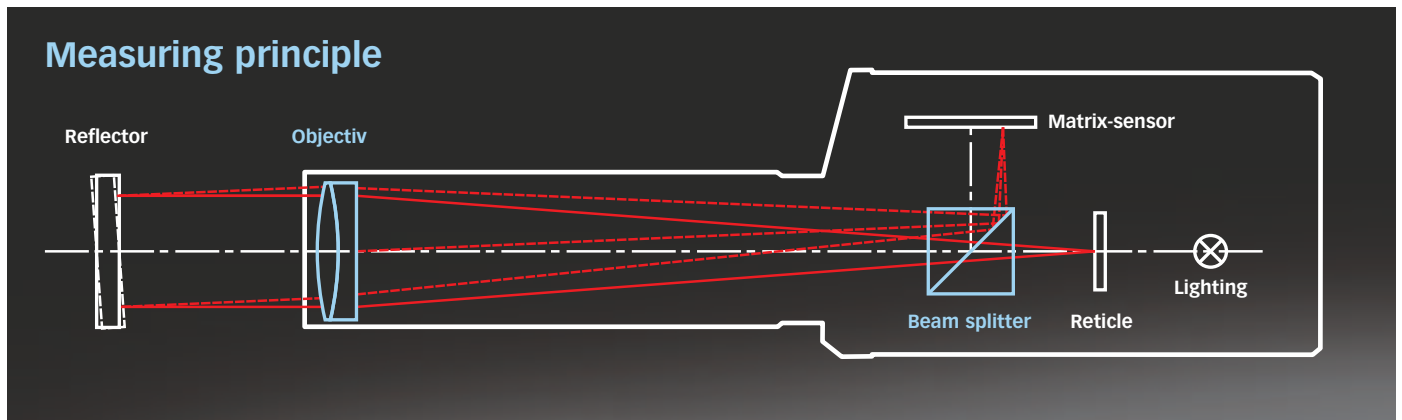
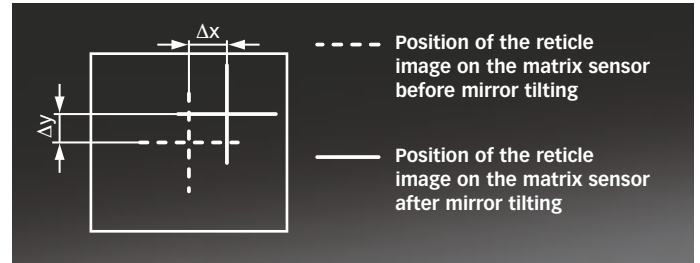

Features

The main features of the ELCOMAT® direct N are:

- Quick and easy measurement of small angles with high accuracy
- Computer based evaluation
- Connection with a computer via a USB 3.0 interface
- Simple operation
- Easy integration into automated processes

A wide range of different focal lengths allows the selection of the most suitable autocollimator for the respective application in terms of measuring range and measurement uncertainty.

Measuring Range and Distance

The measuring range of each autocollimator remains constant up to a certain distance between the autocollimator and the reflector, and then decreases with increasing measuring distance due to vignetting.

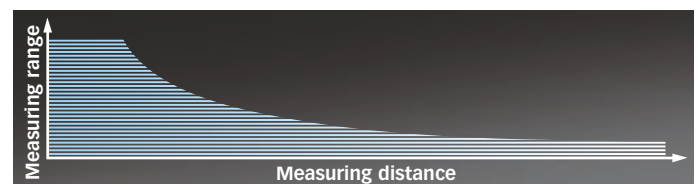

Components of the new ELCOMAT®direct N

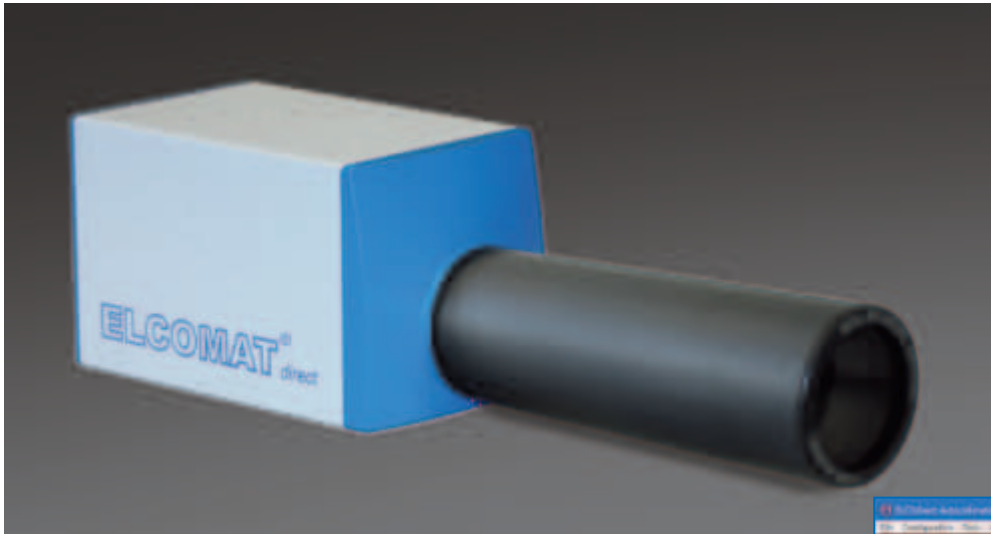

Each ELCOMAT®direct N consists of an autocollimation sensor and the ELCODirect software. ELCODirect is designed for use under Microsoft® Windows on current PCs or laptops with a USB 3.0 interface.

The autocollimation sensor is connected to the computer via the USB interface. A Microsoft® Dynamic Link Library (DLL), which covers the autocollimator functions, is included in the software.

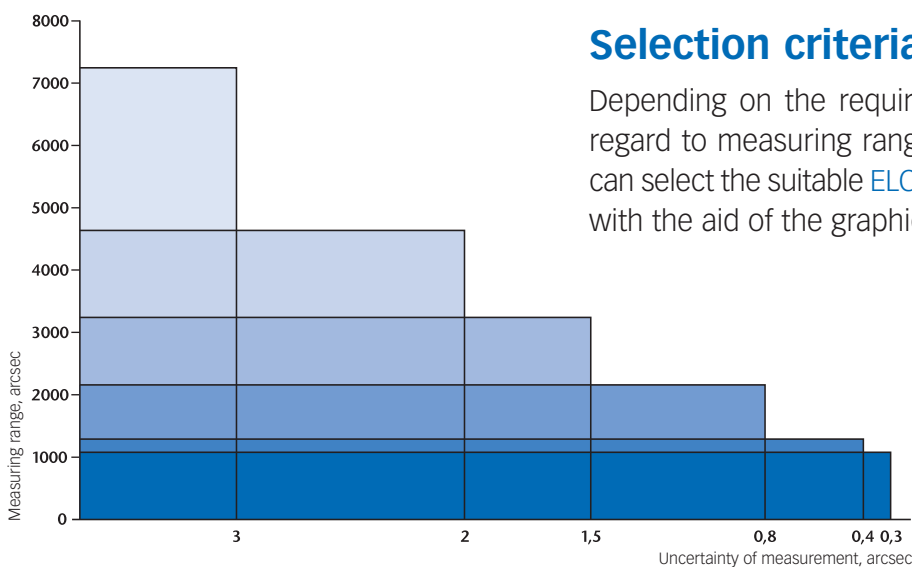

Selection criteria

Depending on the requirements of your measuring task with regard to measuring range and measurement uncertainty, you can select the suitable ELCOMAT®direct N from the product range with the aid of the graphic.

- ELCOMAT®direct N 90
- ELCOMAT®direct N 140
- ELCOMAT®direct N 200
- ELCOMAT®direct N 300
- ELCOMAT®direct N 500
- ELCOMAT®direct N 600

ELCOMAT® direct N

Dimensions of the different ELCOMAT® direct N

The autocollimation sensors of the ELCOMAT® direct N series allow the selection of the most suitable sensor for the application due to the wide range of objective tubes.

The ELCOMAT® direct N housing has two connectors: One for connection to the computer and one for connection of a laser attachment for rough alignment of the autocollimator to the reflector.

ELCOMAT direct N 90 / 40

Art. No. 229 881

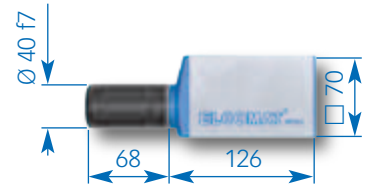

ELCOMAT direct N 140 / 40

Art. No. 229 882

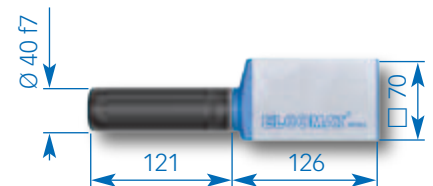

ELCOMAT direct N 200 / 40

Art. No. 229 883

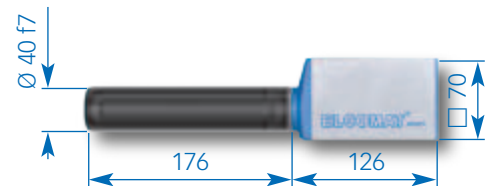

ELCOMAT direct N 300 / 40

Art. No. 229 884



ELCOMAT direct N 500 / 40

Art. No. 229 885



ELCOMAT direct N 300 / 65

Art. No. 229 886

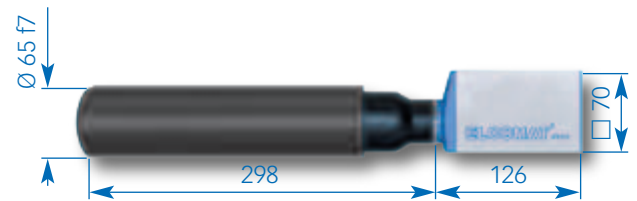

ELCOMAT direct N 500 / 65

Art. No. 229 887



ELCOMAT direct N 500T / 65

Art. No. 229 888



ELCOMAT direct N 600 / 128

Art. No. 229 889

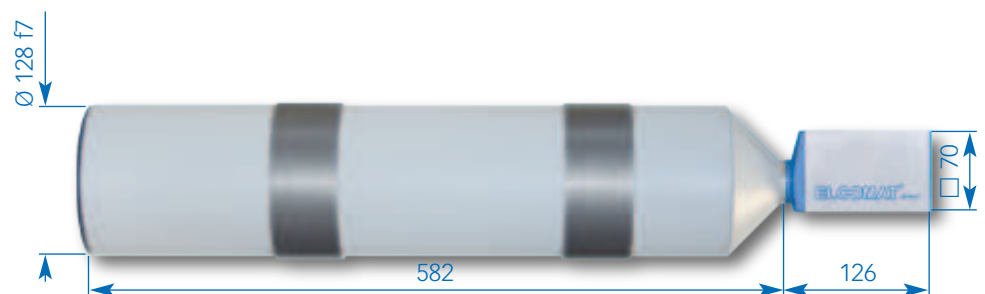

ELCOMAT[®] direct N Software ELCodirect

The ELCodirect software is included with the ELCOMAT[®]direct product series. The software can automatically and simultaneously measure up to 10 cross positions and automatically determine the wedge angle or the error of the 90° angle of 90° prisms.

Note: Runs under Windows[®] / The software is only suitable for the ELCOMAT[®]direct product series!

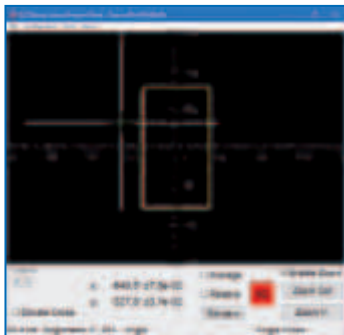
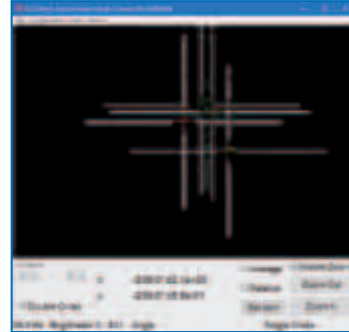

Software Tools

The software provides numerous help functions, such as screen zoom and measurement scale display, to facilitate daily measurement tasks. Advanced parameters such as camera area of interest and exposure time settings can be locked via user configuration to ensure process-safe measurements.

Communication Parameters

The angle measurement values can be provided via a serial COM interface or via a UDP interface. Communication parameters such as baud rate or UDP port can be fully configured in the software.

It is also possible to transfer the measured values via the Windows clipboard to another application on the same computer. Alternatively, you can use the SDK to implement your own applications and integrate the ELCOMAT[®]direct N directly.



Cartesian or Polar Coordinates

The value display can be configured to show angle values, wedge angles, or height differences with respect to a user-defined base length. Values can be displayed in Cartesian or Polar coordinates.

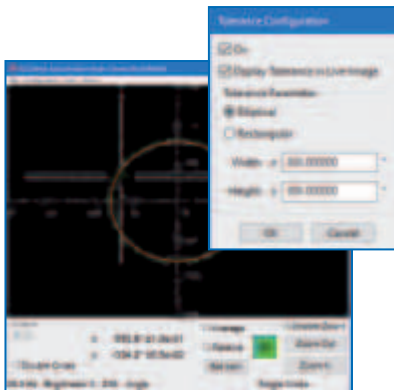
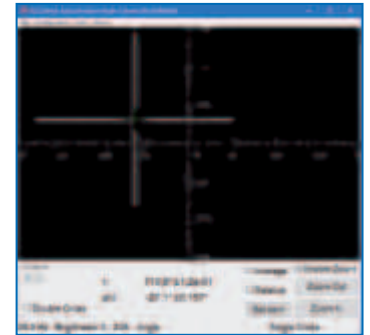
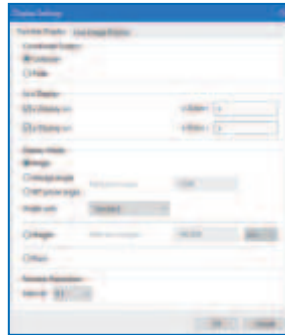

Tolerances

Go/NoGo tolerances can be displayed for quick and easy evaluation of the measurement result.

Centering Mode

In the centering mode of the [ELCOdirect](#) Software, for example, the centering error of optical components in relation to the common optical axis of the entire system or the wobble error of rotary tables, can be calculated.

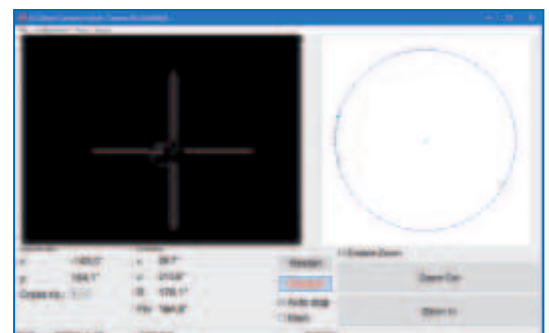

ELCOMAT® direct N

Typical applications

Typical applications for the ELCOMAT® direct N series are:

- Wedge angle measurement
- Angle measurement on 90°-prisms
- Alignment of optical components
- Position uncertainty (rotatory)
- Wobble error
- Centering
- Measurement of surface parallelism

Wedge Angle Measurement

The wedge angle can be measured by either double cross or deflection angle. The first method offers higher accuracy than the second and does not require an additional mirror. A limitation of the method is that it requires a separation of the autocollimation images in the order of the minimum detectable angle difference of the ELCOMAT®. The minimum detectable angle difference of the ELCOMAT® direct N series can be found in the technical data. This results in a lower limit for the measurability of the wedge angle. The second method does not have this limitation. It can also be used for wedges with smaller wedge angles.

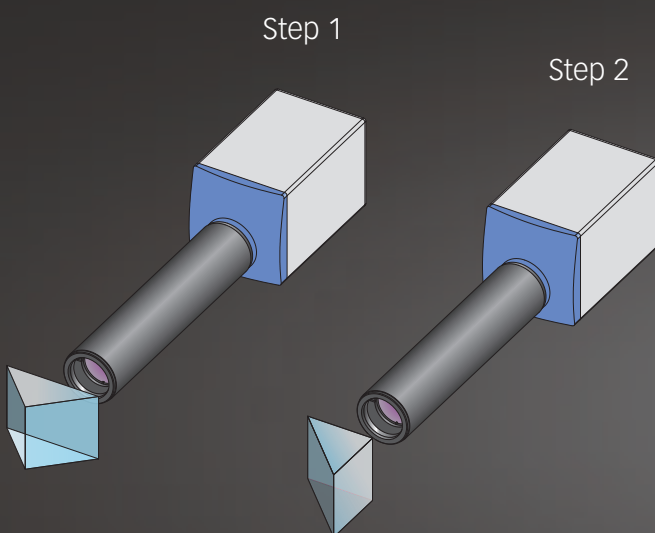
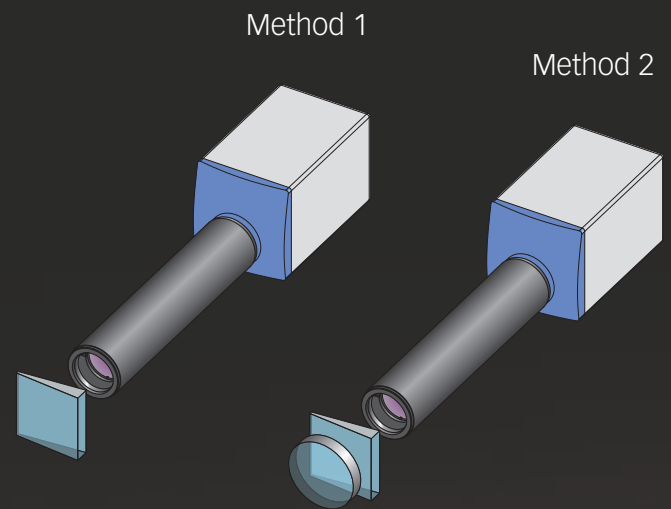

Angle Measurement of 90° Prisms

The measurement of the error of 90° and 45° angles of 90° prisms is performed in two steps. In the first step, the error of the 90° angle is measured. In the second step, the error of the 45° angle is determined. Like the wedge error measurement with double cross, this application is based on multiple cross evaluation and is therefore also subject to the limitation that it requires a separation of the autocollimation images in the order of magnitude of the minimum detectable angle difference. This can be taken from the technical data of the ELCOMAT® direct N product series. This results in a lower limit for the measurability of the deviation of the 90° and 45° angles.

Alignment of optical components

With the ELCOMAT®direct N product series, the alignment of optical components (e.g. prisms and mirrors) is possible. Due to the possibility of simultaneous evaluation of several auto-collimation images, components can even be aligned when autocollimation images of other components appear in the camera image.

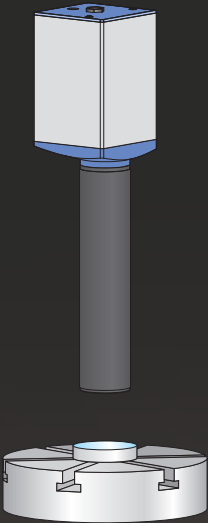
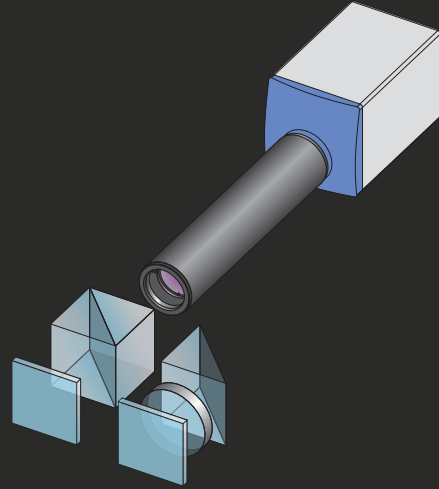

Wobble

Using the centering mode of the ELCODirect and a plane mirror, the ELCOMAT®direct N can be used to determine the wobble of spindles or rotary tables.

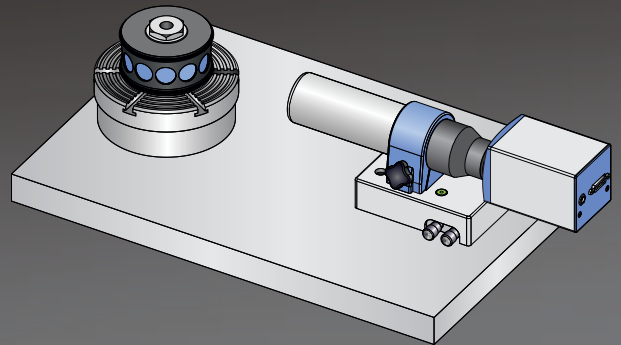
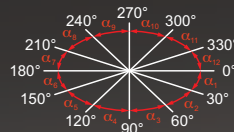

Position Uncertainty (Rotary)

Determine the position uncertainty of indexing and rotary tables and the absolute measurement of polygon mirrors.

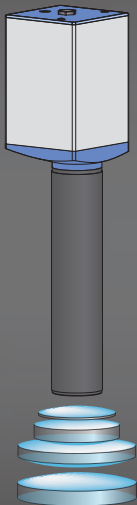

Centering

The ELCOMAT®direct N allows easy and fast measurement of the centering effect in reflection and transmission, even during the assembly of a lens system of single lenses using the centering mode of the ELCODirect software.

ELCOMAT® direct N

Optional accessories

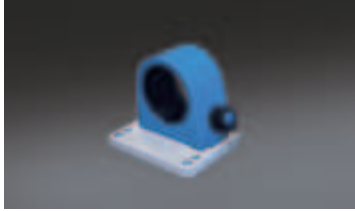

Clamp Fixture

For integration of the ELCOMAT®direct N into existing set-ups
 Height of optical axis: 62 mm
 Mounting: 4 x M6 screws

Description	Art.-No.
Clamp fixture D40	223 035
Clamp fixture D65	223 037
Clamp fixture D128 (not pictured)	223 112



Adjustable Holders (±2°)

For mounting of the ELCOMAT®direct N
 Adjustment range (x,y): ±2°
 Height of optical axis: 100 mm

Description	Art.-No.
Adjustable holder D40	223 057
Adjustable holder D65	223 056

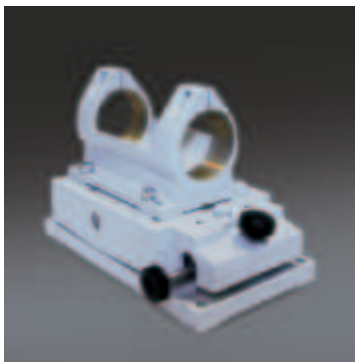

Adjustable Holders (±4°)

For mounting of the ELCOMAT®direct N with increased stability requirements
 Adjustment range (x,y): ±4°
 Height of optical axis: 132 mm

Description	Art.-No.
Adjustable holder with clamp fixture, double-sided D40	223 023
Adjustable holder with clamp fixture, double-sided D65	223 024
Adjustable holder D128 (not pictured)	223 058

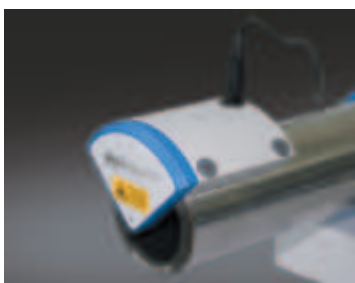

Adjustment Aids

Laser attachment for quick and easy alignment of the ELCOMAT®direct N to a target reflector.

Description	Art.-No.
Adjustment Aid D40	219 767
Adjustment Aid D65	219 757

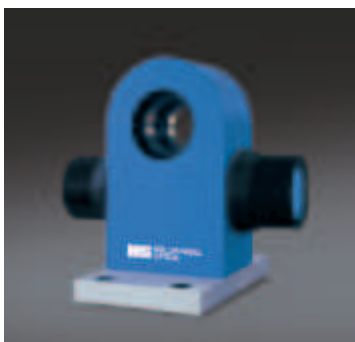

Autocollimator Test-Wedge

Autocollimator test-wedge für quick testing of autocollimators.

The test-wedge is certified and allows on-site testing of angular accuracy.

Description	Art.-No.
Autocollimator Test-Wedge	223 244

ELCOMAT® direct N

Optional accessories

Description	Art.-No.
VA f=50 D10 M36x0.75	221 048
VA f=90 D16 M36x0.75	221 051
VA f=140 D28 M36x0.75	221 053
VA f=200 D28 M36x0.75	221 055
VA f=300 D28 M36x0.75	221 059
VA f=500 D28 M36x0.75	221 063
VA f=600 D28 M36x0.75	221 067
VA f=300 D50 M60x1	221 061
VA f=500 D50 M60x1	221 065

Attachment Achromats

Can be screwed to a D40 or D65 type objective tube to focus collimated beams from an autotolimator to a specified finite distance.



Description	Art.-No.
Polygon Mirror 12 Surfaces 2"	205 313
Polygon Mirror 8 Surfaces 2"	205 307

Polygon Mirrors

Angular measuring standard for the measurement of the rotatory position uncertainty of index or rotary tables.

Mirror: Ø 38 mm (8 surfaces)
Ø 25 mm (12 surfaces)

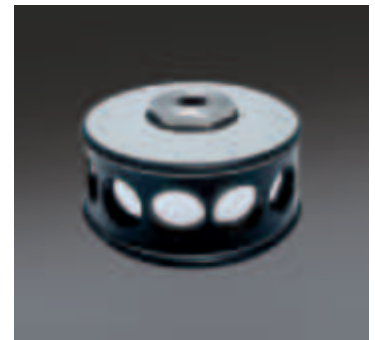

Description	Art.-No.
Tripod D 65	223 089
Tripod D 40	223 086

Tripods

Tripods are a space-saving solution to make the ELCOMAT®direct N to be positioned above a test specimen.



Description	Art.-No.
Vertical tripods D 65 with tilting table	223 107
Vertical tripods D 40 with tilting table	223 108

Vertical tripods

The D65/D40 vertical stand is a very stable, space-saving solution for checking optical flat surfaces.



ELCOMAT® direct N

Optional accessories



Adjustable mirror D63 with Permanent Magnetic Clamp

For use as auxiliary or deflection mirror with an adjustment range 2.5° in both axes. Mounting is possible on a magnetic surface or with 4 M4 screws.

Description	Art.-No.
Adjustable Mirror D63 with magnetic clamp	223 210

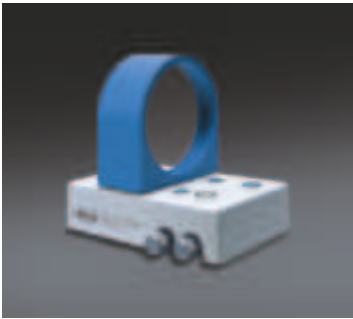

Adjustable Mirror D100

For use as auxiliary or turning mirror with an adjustment range $\pm 2^\circ$ in both axes. Height of optical axis: approx. 100 mm

Description	Art.-No.
Mirror D100 adjustable, double-sided	223 221

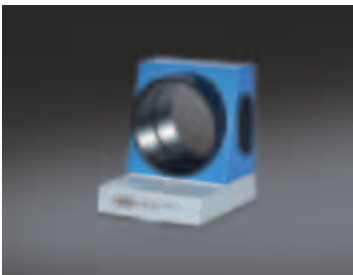

Mirrors D63 in Mount

Can be attached to a magnetic base, for example. Height of optical axis: 55 mm

Description	Art.-No.
Mirror D63 in Mount, one-sided	223 260
Mirror D63 in Mount, double-sided	223 262

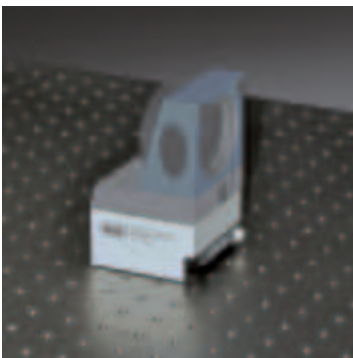

Magnetic Base

For mounting mirrors in mounts to any magnetic surfaces. Height of optical axis: 100 mm (incl. Mirror)

Description	Art.-No.
Magnetic base for mirror additionally required: 223 260 oder 223 262	223 282

ELCOMAT® direct N

Technical Data

ELCOMAT® direct N	90/40	140/40	200/40	300/40	500/40	300/65	500/65	500T/65	600/128
Art.-No.	229 881	229 882	229 883	229 884	229 885	229 886	229 887	229 888	229 889
Measurement uncertainty, arcseconds	± 3.0	± 2.0	± 1.5	± 0.8	± 0.4	± 0.8	± 0.4	± 0.4	± 0.3
Reproducibility, arcseconds	0.4	0.3	0.2	0.1	0.05	0.1	0.05	0.05	0.05
Resolution, arcseconds	0.005 bis 5; selectable								
Recommended minimum resolution, arcseconds	0.5	0.2	0.2	0.1	0.05	0.1	0.05	0.05	0.05
Measuring range, (X) x (Y), arcseconds	7250 x 5400	4640 x 3480	3240 x 2440	2160 x 1620	1290 x 970	2160 x 1620	1290 x 970	1290 x 970	1290 x 790
Max. measuring distance, m	0.2	0.6	1.0	2.0	2.6	2.6	3.4	5.4	10.8
Minimum reflector, R > 85%, mm	ø1.5	ø2.0	ø3.0	ø5.0	ø6.0	ø5.0	ø6.0	ø7.0	ø7.0
Minimum reflector, R = 4%, mm	ø4.0	ø4.0	ø10.0	ø14.0	ø19.0	ø14.0	ø19.0	ø24.0	ø25.0
Minimum detectable angular difference, arcseconds	21.5	13.8	9.6	6.4	3.8	6.4	3.8	3.8	3.2
Measuring frequency, Hz	1 bis 50; selectable								
Focal length, mm	90	140	200	300	500	300	500	500	600
Free aperture, mm	ø16	ø28	ø28	ø28	ø28	ø50	ø50	ø50	ø100
Tube diameter, mm	ø40 f7	ø40 f7	ø40 f7	ø40 f7	ø40 f7	ø65 f7	ø65 f7	ø65 f7	ø128 f7
Dimension, (L x H x B), mm	194 x 70 x 70	247 x 70 x 70	302 x 70 x 70	403 x 70 x 70	603 x 70 x 70	424 x 70 x 70	606 x 70 x 70	424 x 70 x 70	708 x ø128
Weight, kg	1.1	1.2	1.4	1.8	2.4	2.7	3.9	3.1	7.0

Möller-Wedel Optical GmbH

Rosengarten 10
D-22880 Wedel

Tel.: +49 - 41 03 - 9 37 76 10

Fax: +49 - 41 03 - 9 37 76 60

www.moeller-wedel-optical.com

e-mail: info@moeller-wedel-optical.com